

**SWANA RECYCLING TECHNICAL ASSISTANCE**

**FINAL REPORT**

**CITY OF LOCKHAVEN  
COMPOST EQUIPMENT EVALUATION**



**GANNETT FLEMING, INC.**



**HARRISBURG, PENNSYLVANIA**

**MARCH 2008**

**CITY OF LOCKHAVEN  
FINAL REPORT  
COMPOST EQUIPMENT EVALUATION**

**Table of Contents**

	<u>Page</u>
<b>1.0 INTRODUCTION.....</b>	<b>3</b>
<b>2.0 STUDY BACKGROUND.....</b>	<b>3</b>
<b>3.0 PENNSYLVANIA ACT 101 LEAF WASTE REQUIREMENTS .....</b>	<b>4</b>
<b>4.0 INCOMING LEAVES AND YARD WASTE VOLUME .....</b>	<b>5</b>
<b>5.0 CITY OF LOCK HAVEN COMPOST OPERATION .....</b>	<b>5</b>
5.1 Temporary Compost Facility at the Waste Water Treatment Plant.....	6
5.2 Sizing the Compost Facility Based on Incoming Volumes and Equipment.....	6
<b>6.0 CLINTON COUNTY SOLID WASTE AUTHORITY.....</b>	<b>8</b>
<b>7.0 WINDROW EQUIPMENT EVALUATION .....</b>	<b>8</b>
7.1 Windrow Equipment Comparison Summary.....	12
7.2 Optimizing the Use of the Wildcat TS 514.....	12
<b>8.0 CASE WHEEL LOADER EVALUATION .....</b>	<b>13</b>
8.1 Case Wheel Loader Comparison Summary.....	14
8.2 Other Considerations for Wheel Loaders .....	14
<b>9.0 CONCLUSIONS AND RECOMMENDATIONS.....</b>	<b>15</b>
9.1 Conclusions.....	15
9.2 Recommendations.....	15

**APPENDICES**

**Appendix A – Windrow Turner and Case Loader Equipment Specifications**

**CITY OF LOCKHAVEN**  
**COMPOST EQUIPMENT EVALUATION**  
**- EXECUTIVE SUMMARY -**

The City of Lock Haven (Lock Haven) currently delivers leaves to a 2-3 acre Permit-By-Rule compost facility located at the City's Waste Water Treatment Facility. Brush is taken to the Clinton County Solid Waste Authority located in McElhattan less than five miles away. With recent additions of spring and fall yard waste collections and other improvements to the leaf waste collection program, Lock Haven has taken steps to ensure its leaf waste collection program complies with Act 101 and applicable PADEP guidelines. With additional collections and increased program awareness, the volume of leaves and other yard wastes generated by Lock Haven will increase, and will require processing. Lock Haven proposed a **Wildcat TS-514 windrow turner** and a **Case 621D wheel loader** in a recently approved Section 902 Recycling Grant. In this evaluation, GF provided technical guidance to Lock Haven in the final selection of suitable leaf windrow turning equipment to support a sustainable compost operation. As a baseline, it is understood that the proposed equipment will be dedicated to the compost facility and that Lock Haven will expand their composting efforts in the near future, possibly to include a new site and participation by one or more other municipalities.

Based on our equipment evaluation GF recommends Lock Haven procure the following:

**Wildcat TS 514** – Windrow Turner - \$92,900 (as quoted to Lock Haven)

**Case 721E** – Wheel Loader/quick coupler/3.5 cubic yard bucket - \$135,000 (verbal quote from Groff Tractor)

Although GF did not complete a leaf waste collection program analysis or a compost site evaluation during this study, we obtained background information on these programs from Lock Haven. Based on our experience with leaf waste collection, compost operations, and based on information reviewed during this evaluation, GF recommends Lock Haven (refer to Section 9.0 for more detailed recommendations):

- Prohibit the use and delivery of plastic bags to Lock Haven's leaf waste collection program.
- Use the calculations provided in this Report to more accurately estimate leaf quantities and to help estimate the windrows' site and land area requirements.
- Dump loads of leaves in rows/windrows on site as they are delivered, not in piles to be reconfigured later.
- Turn leaf windrows with the TS-514 approximately once per week in the first month after delivery and then 1-2 times per month for the following 5-7 months. Cure leaf compost for two months before distribution.
- At least one of the Lock Haven compost facility staff should be certified in composting through the Professional Recyclers of PA (PROP) compost courses or similar composting course to understand the compost process and operation.

- Conduct routine site maintenance/repair around the windows to prevent rutting. It is recommended Lock Haven pave the area used for active windrow composting if a new, larger compost site is located and operated.
- Identify one or more suitable regional compost sites in the next 12-18 months that has up to five (5) acres for active composting and 2-5 additional acres for curing, traffic ingress/egress, equipment storage, finished material loading, and future expansion.
- Continue a positive, ongoing relationship with the Clinton County Solid Waste Authority to serve as a processor for yard waste and to use as a resource for equipment (i.e. grinder and trommel screen).
- In the future, Lock Haven should sell finished compost and mulch and also charge tip fees for incoming loads if commercial vendors deliver to the site.
- When Lock Haven has a comfortable handle on operating the compost facility, it could identify vendors (e.g. landscapers) that can deliver truckloads of grass on a scheduled/managed basis to accelerate the compost process and to improve the compost product quality.
- Submit for reimbursement through the Act 101, Section 902 Recycling Grant for any additional eligible recycling program and compost costs, including the outstanding cost balance for the recommended Case 721E, which is roughly \$40,000 more than the proposed Case 621D.

## CITY OF LOCK HAVEN FINAL REPORT COMPOST EQUIPMENT EVALUATION

### 1.0 INTRODUCTION

This Report summarizes a study conducted by Gannett Fleming, Inc. (GF) for the City of Lock Haven (Lock Haven), Clinton County, Pennsylvania. This study and evaluation was completed for Lock Haven as part of the Recycling Technical Assistance Program sponsored by the Pennsylvania Department of Environmental Protection (PADEP) and the Solid Waste Association of North America (SWANA). During this study, GF provided the following:

- Reviewed the specifications and suitability of the compost equipment proposed in Lock Haven’s most recent Act 101, Section 902 Recycling Grant;
- Verified calculations of incoming leaf waste quantities;
- Estimated compost site area requirements for windrows;
- Contacted equipment vendors and compost facility operators to obtain information about various windrow equipment operation and effectiveness;
- Provided recommendations related to leaf windrow turning equipment and wheel loaders for pulling the windrow turner, and;
- Completed this report to summarize and document our findings and recommendations.

### 2.0 STUDY BACKGROUND

The City of Lock Haven is the largest municipality located in Clinton County, Pennsylvania. The City is home to roughly **9,149 residents** (2000 US Census Bureau) and encompasses 2.3 square miles. Lock Haven is “mandated” by the Municipal Waste Planning, Recycling and Waste Reduction Act of 1988 (Act 101) to provide curbside recycling services, including the curbside collection of leaf waste. Leaf waste, as defined by Act 101, includes **leaves, garden residues, shrubbery and tree trimmings**, and **similar material**, but not including grass clippings.

In 2007, PADEP notified Lock Haven that they should implement a collection and processing program for leaf and yard waste that meets Act 101 requirements and PADEP policies and guidelines. In order to properly manage their leaf waste, Lock Haven successfully submitted an application for a Permit-by-Rule compost facility. Yard waste pickups were also added to the curbside program. Brush is taken to the nearby Wayne Township Landfill operated by the Clinton County Solid Waste Authority. This evaluation is to assist Lock Haven in selecting appropriate leaf windrow turning equipment, which will facilitate compliance with applicable leaf waste management regulations and help Lock Haven operate an efficient, sustainable composting program that will benefit the local community.

### 3.0 PENNSYLVANIA ACT 101 LEAF WASTE REQUIREMENTS

It is important to understand the requirements that govern the methods and frequency by which leaf waste must be collected and managed by Lock Haven to be in compliance with Act 101. Collection frequency impacts the incoming material quantities, which in turn affects the processing and equipment needs. The following guidance information was prepared by PADEP in May, 2007 to help Act 101 mandated municipalities like Lock Haven to better understand and meet their requirements for managing leaf waste. Lock Haven will need to implement a leaf waste management program consistent with these regulatory requirements. With the recent addition of spring and fall yard waste collection, and as supplemented by the Clinton County drop-off location, Lock Haven's leaf waste program appears to comply with the regulations.

Act 101, Section 1501(c)(1)(ii) and (iii), requires residents in mandated municipalities to separate leaf waste from other municipal waste generated at residential, commercial, municipal and institutional establishments. "Leaf waste" is defined in the Act as "Leaves, garden residues, shrubbery and tree trimmings, and similar material, but not including grass clippings." Source-separated leaf waste, as with other recyclable material, is required to be collected at least once per month as set forth in Act 101 Section 1501(c)(2) and (3) and processed at PADEP-approved composting facilities.

Municipalities that are mandated to comply with Act 101 which have programs that collect leaves only in the fall are not in compliance with the Act. In order for municipalities that are mandated to comply with Act 101 to have a leaf waste collection program that meets the minimum requirements, the program must, as a minimum:

1. Require by ordinance that leaf waste consisting of leaves, garden residues, shrubbery and tree trimmings, and other similar material are targeted for collection from residences and commercial, municipal and institutional establishments; and
2. Establish a scheduled day, at least once per month, when leaf waste is collected from residences; or
3. Establish a scheduled day, not less than twice per year and preferably in the spring and fall, when leaf waste is collected from residences, and facilitate a drop-off location or other collection alternative approved by PADEP that allows residents in the municipality to deposit leaf waste for the purposes of composting or mulching at least once per month. The leaf waste drop-off location may be located in a neighboring municipality or at a private sector establishment, provided that an agreement is in place to utilize that location and the municipality keeps residents and commercial, municipal and institutional establishments informed of the option at least once every six months.
4. Ensure that commercial, institutional and municipal establishments generating leaf waste have collection service.
5. Municipalities are encouraged to manage source separated Christmas trees as leaf waste for processing at PADEP-approved composting facilities.

#### 4.0 INCOMING LEAVES AND YARD WASTE VOLUME

Leaf collection is provided by Lock Haven’s Public Works crews in October and November, with the actual collection periods being affected by the weather conditions in a given year. In 2007, due to extended warm temperatures, many municipalities found themselves collecting leaves much later in the season than is typical.

The total estimated quantity of leaves and yard waste collected for recycling in calendar years 2006 and 2007 are shown below. These figures were corrected by GF after it was noted that the leaf box capacity used in the original estimates (5.5 cubic yards) was incorrect. In 2006, there were 117 loads of vacuumed leaves and no brush/yard waste was collected. In 2007, there were a total of 141 loads of leaves collected with 68 of these loads being leaves collected in plastic bags. In the spring of 2007, **1.46 tons** of brush/yard waste collected. Leaf quantities were estimated using 400 lbs. per cubic yard for vacuumed, slightly compacted leaves. Truck volume was estimated at 13 cubic yards at a 75% fill rate (or approximately 10 cubic yards) which equates to 4,000 lbs. per truck load, using the same pounds per cubic yard as vacuumed leaves. Tons were then calculated by multiplying 4,000 lbs. per truckload by the total number of loads and then dividing by 2000. There were roughly **234 tons** of leaves collected in 2006 and **282 tons** of leaves collected in 2007. All bagged material was emptied at the compost site.

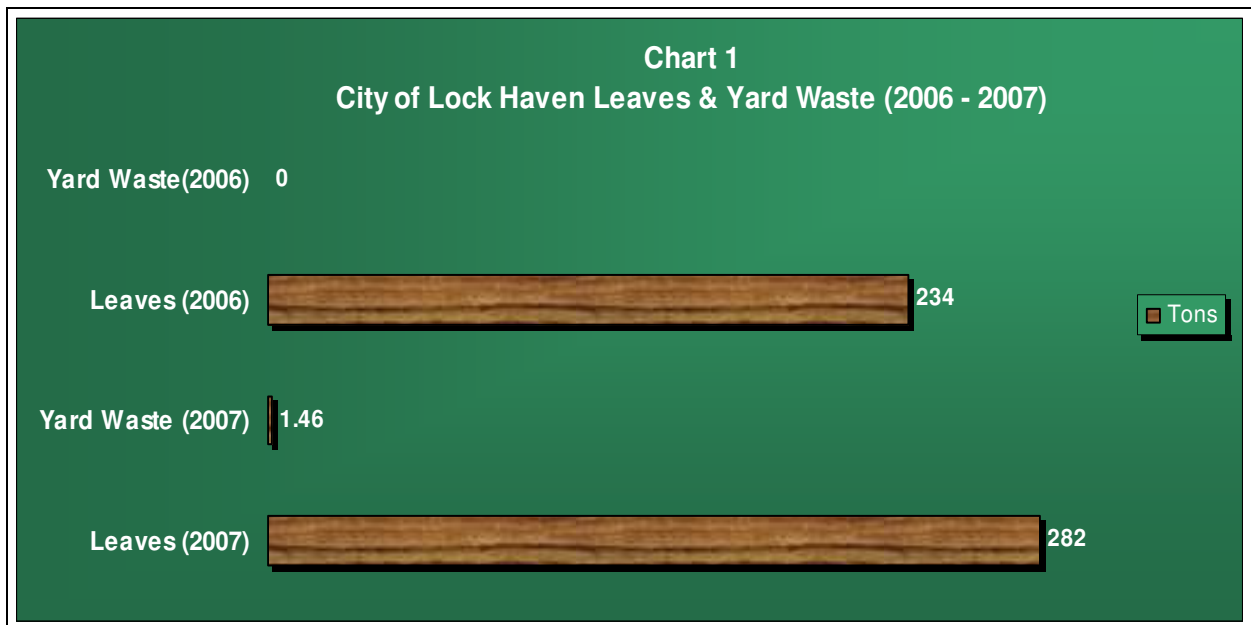

#### 5.0 CITY OF LOCK HAVEN COMPOST OPERATION

At this time, Lock Haven’s compost operation will be primarily for the purpose of processing/composting leaves that are collected by Lock Haven’s Public Works crews. Brush collected by Lock Haven can, and is, taken to the Wayne Township Landfill for processing into mulch. The landfill compost site can also be used for residential yard waste drop-off (see Section 5.0).



## 5.1 Temporary Compost Facility at the Waste Water Treatment Plant

Currently, the Lock Haven compost operation is located at the Waste Water Treatment Plant (WWTP). The 2-3 acre site is operated under the PADEP Permit-By-Rule compost guidelines for yard waste compost facilities less than five acres in area. The guidelines establish siting criteria, compost methods and requirements, and require the facility to meet a maximum material loading rate of 3,000 cubic yards per acre for the active composting area.

In 2006 and 2007, leaves were unloaded on the 2-3 acres of unpaved composting area. It is envisioned that the WWTP compost site will be temporary, used only to meet current disposal needs and regulatory requirements for managing leaf waste. In the next two to three years, Lock Haven anticipates identifying a larger compost site that will be suitable for serving the Lock Haven's processing needs for leaves as well as meeting the leaf processing needs of several other local municipalities. Lock Haven is planning for a more economically sustainable program through cooperation with other municipalities, which will increase material volumes processed and ultimately result in revenue from Leaf Waste disposal fees and the sale of finished compost.

Based on GF's experience with municipal compost facilities, the current 3-acre WWTP compost facility is too small to effectively meet the demands for processing leaf waste as part of a comprehensive and long-term facility for composting. However, three acres is adequate for a shorter term option for composting leaves at current volumes, particularly if windrows are turned frequently to accelerate composting, the compost quality is maintained, and material does not accumulate on site from one year to the next year. Additional information and calculations on windrows and facility sizing are in the following section.

In the future, if Lock Haven decides to apply for a General Permit (GP) under the current general permit for a compost site over 5 acres, the application fee is \$500, presently.

## 5.2 Sizing the Compost Facility Based on Incoming Volumes and Equipment

When the fall leaf collection period is completed, space will be taken up by windrowed leaves before they settle and begin to decompose. The initial area needed will be determined by how many leaves are collected, how densely they are packed, and how the windrows are constructed and configured. Lock Haven placed an estimated total 2,580 cubic yards (~516 tons) of leaves at the WWTP site in 2006 and 2007. When Lock Haven begins to utilize a windrow turner, the size reduction of windrows can be accelerated, and as the composting process advances, combining piles may be necessary to maintain an optimum windrow size. Combining piles can reduce the land area used by windrows but this does not affect the initial amount of space needed to accommodate leaves unloaded as received at the site.

GF completed some preliminary calculations to give Lock Haven an idea of how many cubic yards of leaves are contained in a windrow and how much space is required for windrows appropriately constructed for processing by a windrow turner. These calculations are for estimating purposes only and can be greatly influenced by the density of the leaves, which is highly variable. Additionally, the accuracy of the data for incoming truckloads of leaves will directly impact the estimates. In this analysis, GF has not anticipated or calculated the necessary



size of a compost facility operated by Lock Haven that would receive material from other municipalities as part of a regionalized effort.

The quantity of material that can be placed on one acre will correlate to the dimensions of the windrows that are constructed. The dimensions of the windrows are limited by the type of equipment that is available for turning the windrows. As a result of our investigation into the most appropriate equipment for Lock Haven, GF has selected windrows sized and configured for turning by the Wildcat TS 514. Windrows will be constructed in pairs as shown below. For this example, windrows configured in pairs for the TS 514 would have the following dimensions: **W = 14'** **H = 5'** **L = 160'**. Assuming one acre is approximately 220' x 220' and the 30' turning radius on each side reduces the distance on two sides a total of 60', a windrow fitting on one acre using the TS 514 will be 160' long.

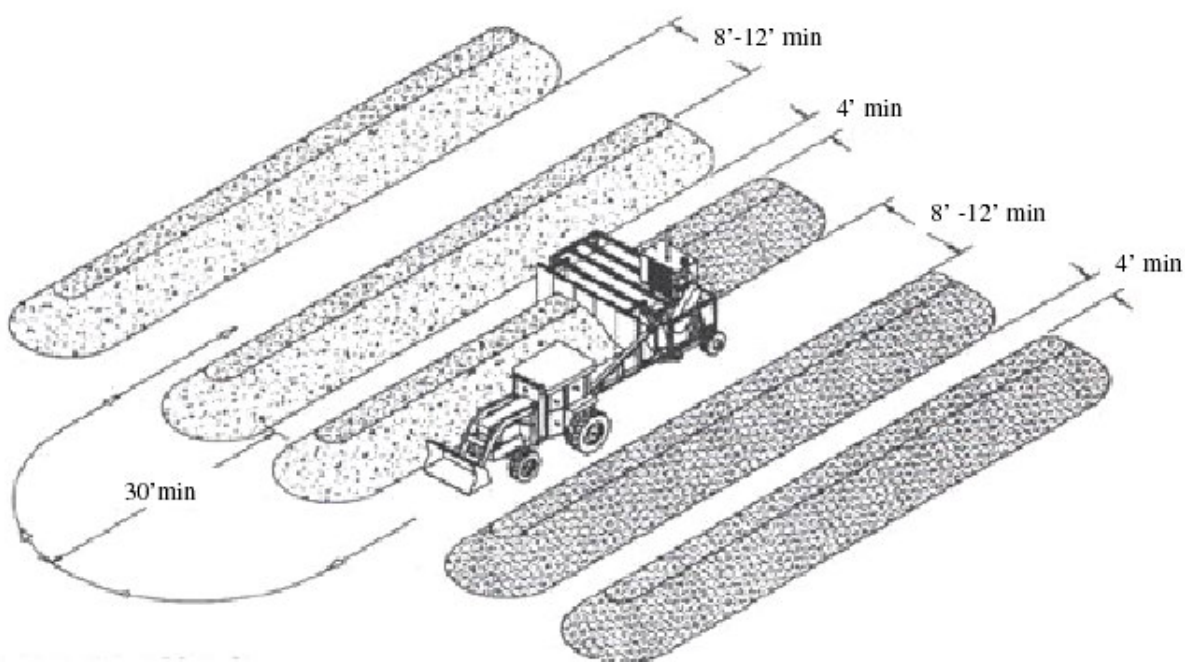

GF used the area formula for windrows that is recommended by the PADEP: Area (A) = .67 x Width (W) x Height (H). The cubic yards can then be calculated by dividing (A) by 27 or  $A/27$ . Using the above configuration, there would be approximately 280 cubic yards in every 160' windrow. Configured in pairs with 4' between pairs and 12' between sets of pairs, 4-5 windrows can be constructed which equates to 1,120 cubic yards to 1,400 cubic yards on one acre. It is recommended that Lock Haven maximize the length of the windrow construction beyond 160' to the extent feasible to increase the total amount of windrowed material per acre and to increase the efficiency of turning the windrows and operating the compost site. In 2007, the 1,410 cubic yards of leaves collected by Lock Haven would cover about one acre windrowed in pairs. If 2006 and 2007 leaves remain, 1.5 – 2.0 acres for active composting should be adequate. Since leaf collection and composting are in the early stages of promotion by Lock Haven, it is expected incoming material will increase.

Clearly, any standard windrow configuration at Lock Haven's compost site will not exceed the permitted loading rate of 3,000 cubic yards per acre. However, Lock Haven must pursue removing accumulated piles of compost or ground yard waste located in the active composting area of the compost site on an annual basis. Otherwise annual carry-over could lead to accumulated piles that exceed loading requirements. PADEP has historically been lenient concerning loading rate maximums provided the compost facility is being operated satisfactorily.

## 6.0 CLINTON COUNTY SOLID WASTE AUTHORITY

Lock Haven is located less than five miles from the Wayne Township Landfill that is operated by the Clinton County Solid Waste Authority (Authority) in McElhattan, Pennsylvania. The Authority accepts brush and yard waste, pallets, and other wood material. There is no charge for dropping off clean loads of brush and yard waste. The Authority will not accept bagged leaf waste. Grass is not accepted. The Authority owns a Morbark Model 1300 Tub Grinder and Morbark Trommel Screen, which are used to process the wood material into landscape mulch. Mulch is sold to residents as follows:

**Natural mulch:** \$13-14/Cubic Yard

**Colored mulch:** \$22/Cubic Yard

The Authority has worked with Lock Haven to address their yard waste processing needs in the past and will continue to assist Lock Haven as feasible. Processing equipment is available for rent by Lock Haven to grind wood waste and screen material. The Authority has said it is willing to assist with grinding woody material one day each year at no cost.

## 7.0 WINDROW EQUIPMENT EVALUATION

As included in the Act 101, Section 902 Grant Application, the City of Lock Haven proposed the following pieces of equipment for its compost program:

**Wildcat TS 514:** Windrow Turner - \$92,900

**Case 621D:** Wheel Loader - \$96,333

GF conducted an evaluation of the proposed equipment items by contacting equipment vendors, reviewing comparable compost equipment, and through contacting several compost facilities in Pennsylvania. Equipment specifications gathered during this research are attached for reference in **Appendix A**. Since the initial capital cost for the recycling equipment is 90 percent reimbursable through the Act 101, Section 902 Recycling Grant program, and because Lock Haven has been awarded funding, GF focused the analysis on operating costs and equipment operating efficiency. Up-front capital costs are not a primary factor in this life cycle cost analysis. Lock Haven will be impacted by the ongoing utilization, costs and performance of the selected equipment.

Knowing the total amount of the grant award, GF did not review windrow equipment that greatly exceeded the price range of the grant amount. Closed-cab drive-type windrow composting machines like models available by Scarab and Frontier were not reviewed due to the approximate

cost of this equipment being in excess of \$300,000. These drive-type windrow turners are not practical for the small quantity of leaves that require processing at the Lock Haven compost site, even for the foreseeable future. GF also made the determination to limit the evaluation to windrow turners that can turn piles a minimum of five feet in height. It is not recommended to manage leaf waste windrows below much less than 5 feet in height because: 1) it is difficult to maintain temperatures high enough to optimize the compost process in smaller windrows; and 2) the height of the windrow has a significant impact on the total windrow/material volume on a given footprint, thus smaller windrows will not optimize the use of space on the compost site.

Although there are many operating factors, some of the key considerations for this compost equipment analysis included:

### **Windrow Turners**

- Total annual operating costs (labor, fuel, parts and maintenance)
- Throughput or processing capacity – cubic yards per hour (turning)
- Equipment impact on windrow configuration/site space utilization
- Overall equipment efficiency

### **Wheel Loaders**

- Total annual operating and maintenance costs
- Bucket capacity
- Overall equipment efficiency
- Equipment versatility

Some of the comparable equipment that was reviewed included:

### **Aerometer PT 170 – One-pass, pull-behind straddle turner**



**Earthsaver CT-12-PTO – One-pass, pull-behind straddle windrow turner**



**Vermeer CT670 – Two-pass Elevated face, windrow turner**



Windrow Turning Equipment	Notable Pros	Notable Cons
<p><b>Wildcat TS-514</b> (proposed – one-pass)</p>	<ul style="list-style-type: none"> <li>- On State COSTARS Piggy Back Program (no bid required).</li> <li>- Turns at 40’ – 50’ per minute.</li> <li>- Windrows are 5’H x 14’ W; comparably high volume per windrow.</li> <li>- Windrows maintain shape and position when turned.</li> <li>- Paired windrow configuration optimizes compost site area.</li> </ul>	<ul style="list-style-type: none"> <li>- Processing capacity potential of this vehicle is 2,000 – 2,300 tons per hour which is the highest of those analyzed; this composter may be underutilized unless the City increases the amount of material requiring processing.</li> <li>- Some uneven stresses on equipment from side pull; but equipment has evolved to have reinforced connectors and 4”x12” heavy duty durable flails.</li> </ul>
<p><b>Aeromaster PT-170</b> (one-pass)</p>	<ul style="list-style-type: none"> <li>- Lift out feature is helpful for getting out of material if bogged down.</li> <li>- Paired windrow configuration optimizes compost site area.</li> </ul>	<ul style="list-style-type: none"> <li>- Very triangular or peaked windrow shape reduces volume per windrow and inhibits water absorption.</li> <li>- Turns at 20’ – 35’ per minute; slower than Wildcat TS-514.</li> </ul>
<p><b>Earth Saver CT-12 PTO</b> (one-pass)</p>	<ul style="list-style-type: none"> <li>- Central pull system minimizes uneven stress/wear on equipment.</li> <li>- Paired windrow configuration optimizes compost site area.</li> <li>- Does not use fuel since it is not self-powered unit.</li> </ul>	<ul style="list-style-type: none"> <li>- Turns at 10’ – 25’ per minute; much slower than Wildcat TS-514.</li> <li>- &gt;5’ H x 12’ W windrows.</li> <li>Is not a self-powered unit which can potentially be damaged from stress forces when pulled by a loader.</li> <li>- Not currently being manufactured; must get used.</li> </ul>
<p><b>Vermeer CT670</b> (two-pass)</p>	<ul style="list-style-type: none"> <li>- Low HP means lower fuel usage per unit of time.</li> <li>- Complete mixing each turn with elevated face technology that brings material from the bottom of the windrow up the wedge-shaped equipment face.</li> <li>- Performs the turning function from the side and therefore, pile height is less of a constraint; piles can be processed up to 7’H to 8’H.</li> </ul>	<ul style="list-style-type: none"> <li>- Pulling through ½ pile is less efficient overall than one-pass options; requires more labor time. Pulling through ½ pile places uneven wear on equip. and case studies reveal high maintenance and replacement of teeth and welds required. Piles are not paired requiring additional site footprint. Piles move and become wider during turning requiring some pile rebuild with loader.</li> </ul>
<p><b>Note: Initial capital cost was not a focus of this equipment comparison</b></p>		



## 7.1 Windrow Equipment Comparison Summary

The Wildcat TS 514 proposed for use by Lock Haven is a proven piece of equipment that has been successfully operated on yard waste compost sites in Pennsylvania and in many other states. The compost industry has increased production of single-pass straddle type turners over the last 10 years because of their operational efficiency. The Wildcat TS 514 is a high-horsepower machine that partially offsets some annual operating costs (compared with other turning equipment), like higher fuel consumption, by its ability to move through windrowed organics quickly and efficiently. Turning efficiency of this machine is particularly noticeable in the first pass when unturned windrows require the most energy to mix. Labor time can also be saved when compared with some other windrow turners because the TS 514 maintains consistently shaped windrows during turning, which reduces the amount of additional labor and operational expense for rebuilding windrows with a loader. The windrows formed by the TS 514 (5'H x 14'W) are suitably sized to maintain heat and active composting. This turner also optimizes space utilization of the compost site because it turns windrows in pairs or sets that are close together (refer to windrow schematic in Section 5.2), reducing waste aisle space.

The exception to the Wildcat TS 514 being the most efficient unit is the gas consumption per operating hour, which is higher than some similar equipment options. Overall the Wildcat TS 514 is quality piece of equipment that will efficiently process windrowed leaf and yard waste. With initial capital costs paid up front, the TS 514 has the greatest potential of the equipment reviewed (those shown and some not reviewed in detail in this Report) to be a long-lasting efficient straddle-type windrow turner that will minimize the amount of staff time spent turning windrows.

General Comments: All of the turning equipment reviewed was capable of creating quality compost assuming adequate feed stock and pile management. Vermeer is in the process of buying Wildcat.

## 7.2 Optimizing the Use of the Wildcat TS 514

The Wildcat TS 514 can turn a 200' leaf windrow in under 10 minutes. Optimizing the processing potential of the high-capacity Wildcat TS 514 will require the City of Lock Haven to increase the volume of material handled. At current volumes of Lock Haven leaves that require processing, Lock Haven will not be able to utilize the processing potential of this machinery, which can contribute to higher costs when considering the full life-cycle costs of the compost operation. Therefore, Lock Haven should look to increase the quantity of leaves accepted and processed. Within a certain operational cost balance, the more quality compost that can be produced and sold, the better Lock Haven will be able to offset the operational costs. At the same time, Lock Haven will increase operational costs as the number of times windrows are turned increases. Typically, turning leaf and yard waste windows twice in the first couple weeks of arrival is recommended. Additional turnings once-per-month for 6-8 months until the material is ready for curing is a commonly used schedule. It is noted that some compost facilities increase turning frequency to as often as weekly or multiple times per week to reduce the time the material is in the active windrow compost phase. This is usually done to expedite the production and sale of finished compost material, which in turn creates space at the compost site.

Increased turning increases operational costs; therefore, this activity should be managed carefully to determine the economic cost benefit. When not in use by Lock Haven, the turner could be rented to other municipalities to optimize equipment use and to help Lock Haven offset compost site costs.

### 8.0 CASE WHEEL LOADER EVALUATION

GF has observed Case wheel loaders at the majority of compost sites operated in Pennsylvania. Operators have been satisfied with Case loaders, and their operation costs and maintenance have been routine, not problematic. Compost site operators report routine maintenance cost for Case loaders being \$1,000 - \$2,000 per year. Because Case is a reliable wheel loader, available from local dealers (such as Groff Tractor), and is suited to pull the Wildcat TS 514, GF evaluated the proposed Case 621D loader for its suitability and compared it to the Case 621E and 721E. GF has assumed that the wheel loader will be used regularly on an open-space compost site and that the City of Lock Haven will continue to expand its compost operation.

Wheel Loaders	Notable Pros	Notable Cons
<p><b>Case loader – 621D</b> (proposed)</p>	<ul style="list-style-type: none"> <li>- Overall very reliable.</li> <li>- Smaller vehicle size increases maneuverability.</li> <li>- Less gas consumption per operating hour than Case 721.</li> </ul>	<ul style="list-style-type: none"> <li>- Lighter than the 621E and 721E.</li> <li>- Smaller bucket size (2.5 – 3.0 cubic yards) Smaller than 721.</li> <li>- Compost operators pushing/pulling straddle loaders reported excess wear, tear and stress imparted on this lighter weight, lower HP vehicle compared to Case 721.</li> </ul>
<p><b>Case loader – 621E</b></p>	<ul style="list-style-type: none"> <li>- Electronically controlled Tier III emissions engine increases fuel efficiency (over the 621D).</li> <li>- Excellent visibility (improved over the 621D): improved safety.</li> <li>- 2.5 - 3.0 Cubic Yard bucket capacity.</li> <li>- Daily service checkpoints made easy view/access to facilitate monitoring and maintenance (improvements over the 621D).</li> </ul>	<ul style="list-style-type: none"> <li>- Slower than Case 721 moving across open distance.</li> <li>- Compost operators pushing and pulling straddle loaders reported excess wear and tear and stress imparted on this lighter weight, lower HP vehicle compared to Case 721.</li> </ul>
<p><b>Case loader – 721E</b></p>	<ul style="list-style-type: none"> <li>- Electronically controlled Tier III emissions engine increases fuel efficiency.</li> <li>- Very versatile: range of motion/bucket height</li> <li>- High torque/HP decrease wear /tear from lifting.</li> <li>- Higher vol. bucket capacity (3.5 Cubic Yards)</li> <li>- Daily service checkpoints made easy view/access to facilitate monitoring and maintenance.</li> <li>- Increased speed: efficient site movement.</li> <li>- Additional weight and HP better suited for towing/pushing heavy equipment.</li> </ul>	<ul style="list-style-type: none"> <li>- Larger vehicle may be limited in some applications due to size.</li> </ul>



## 8.1 Case Wheel Loader Comparison Summary

GF believes the Case 721E loader is a sound choice for Lock Haven's compost operation and it fits well into the plan for a growing regionalized compost facility. The additional vehicle weight and horsepower is more suited for pulling the straddle turner and for continuous material handling. The E-series of Case loaders, including Case 721E, has improved operator access/viewing of daily service checkpoints that facilitates vehicle monitoring (i.e. preventative maintenance) and overall maintenance ease. For managing yard waste and compost, the 3.5 bucket capacity on the Case 721E is operationally efficient compared to smaller volume buckets; moving more material each scoop.

The 721E is a safer vehicle than the proposed Case 621D because the modifications to the cab increase visibility for the operator. Compost sites can be high-traffic areas and operator view is a critical feature. The additional visibility of the bucket is particularly beneficial for composting operations because the operator can more easily identify unwanted debris before it is loaded, potentially causing costly damage to processing equipment like a grinder or screener. The additional bucket lift height of the Case 721E ensures the ability to load larger trucks with compost. Case touts the E-series for the operator comfort and ergonomics that can improve operator productivity. Similar to the windrow turner, optimizing the usage of the wheel loader will require the facility to increase its incoming leaf and yard waste volumes.

State College Borough successfully used the Case 621 for years at their compost facility, but recently moved to the Case 721E to improve operation efficiency, to reduce overall wear and tear on the wheel loader, and to load tri-axle trucks with compost.

## 8.2 Other Considerations for Wheel Loaders

If Lock Haven has dedicated equipment operators, they should be included in the decision making process for the wheel loaders. Equipment operators may have experience with, and be comfortable on certain types of equipment - this should be factored into the final equipment choice. For example, the Lehigh County Compost Facility uses Case loaders for some things but uses John Deere loaders primarily for compost site operations because their operators felt John Deere loaders were more stable on the uneven terrain on Lehigh's compost site.

The Case 621D, 621E and 721E are all suitable equipment for working on a compost site. The E-series of Case loaders is an improvement over the D-series that improves the long-term operational efficiency, safety and maintenance compared to the Lock Haven -proposed Case D-series. As a dedicated loader for a compost facility, expected to be worked frequently as Lock Haven's program expands, the Case 721E has advantages and efficiencies over the 621D and 621E.

## 9.0 CONCLUSIONS AND RECOMMENDATIONS

### 9.1 Conclusions

At the current time, Lock Haven delivers leaves to a 2-3 acre Permit-By-Rule compost facility located at the Waste Water Treatment facility and brush is taken to the Clinton County Solid Waste Authority. With recent additions of yard waste collections and improvements to the leaf waste collection program, the City of Lock Haven has taken steps to ensure its program complies with Act 101 and applicable PADEP guidelines. With additional collections and increased program awareness, the volume of leaves and other yard wastes generated by Lock Haven will increase, and will require processing, usually into compost or mulch. In this evaluation, GF provided technical guidance to Lock Haven in the selection of suitable leaf windrow turning equipment to support a sustainable compost operation. Lock Haven proposes a Wildcat TS-514 windrow turner and a Case 621D wheel loader, as submitted in their approved Section 902 Recycling Grant.

Lock Haven proposes to identify and operate a larger compost site in the future that may supplement the leaf and/or leaf processing needs of several local municipalities. This regional approach to composting can be more sustainable than managing only Lock Haven generated yard waste because finished compost can be sold for revenues, tip fees may be assessed for dropping off materials for processing, and cost sharing arrangements for processing equipment can all be used to help offset operational costs.

### 9.2 Recommendations

Based on our evaluation of equipment, and with the understanding that Lock Haven plans to expand the compost operation in the future, GF recommends Lock Haven procure the following:

**Wildcat TS 514** – Windrow Turner - \$92,900 (as quoted to Lock Haven)

**Case 721E** – Wheel Loader/quick coupler/3.5 cubic yard bucket - \$135,000 (estimated)

**NOTE:** *The recommendation for the 721E including a 3.5 cubic yard bucket, which is a larger loader than originally proposed by Lock Haven, assumes that the loader will be dedicated for use at the compost site and not used in confined areas and/or for handling of other non-leaf and/or yard waste materials. For example, a smaller loader operates better when space is limited and a smaller bucket size (e.g. 2.75 cubic yards) or possibly a multi-functional bucket would be recommended for a loader used to handle fine aggregates, perform grading, etc.*

Although GF did not complete a leaf waste collection program analysis or a compost site evaluation during this study, we obtained background information on these programs from Lock Haven. Based on our experience with compost operations, and based on information reviewed during this evaluation, GF recommends Lock Haven:

- Prohibit the use and delivery of plastic bags to Lock Haven’s leaf waste collection program. Paper bags and/or hard containers can be used as leaf and yard waste collection containers. Plastic bags are not part of a sustainable compost operation because they increase handling/labor

costs, can damage or slow compost equipment, require disposal, and reduce the value of finished compost.

- Use the calculations provided in this Report to more accurately estimate leaf quantities and to help estimate the windrows' size and land area requirements. Prior data based on 5.5 cubic yard leaf boxes incorrectly underestimated total annual quantities.
- Dump loads of leaves in rows/windrows on site as they are delivered, not in piles to be reconfigured later. Turn leaf windrows with the TS-514 approximately once per week in the first month after delivery and then 1-2 times per month for the following 5-7 months. Cure leaf compost 2 months before distribution. It is noted that the compost turning will accelerate the compost process to a point, but a balance must be struck between the compost process, particle size reduction from turning, and increased operating costs. Excess turning of leaves will restrict air flow within the windrows and slow down composting unless a bulking agent like woodchips is introduced.
- GF recommends one or more Lock Haven staff that will work on the compost site is certified in composting through the Professional Recyclers of PA (PROP) compost courses or takes some other composting course to understand the compost process.
- Since the current compost site is not paved, and rutting from equipment can lead to water ponding, reduced operational efficiency, and can cause additional wear on equipment, it is recommended Lock Haven conduct routine site maintenance/repair around the windrows. If Lock Haven relocates and expands its compost operation, it is recommended Lock Haven pave the area used for active windrow composting.
- Identify one or more suitable regional compost sites within 12 months that has up to five (5) acres for active composting and 2-5 additional acres for curing, traffic ingress/egress, equipment storage, finished material loading, and future expansion. The existing WWTP composting operation will benefit by moving to another site that will have capacity to accept more material, eliminate operating restrictions that may be associated with the WWTP location, and to further maximize the opportunity of the site as an economically sustainable site with benefit to several local communities.
- Continue a positive ongoing relationship with the Clinton County Solid Waste Authority to serve as a processor for yard waste and to use as a resource for equipment (i.e. grinder and trommel screen). It is recommended Lock Haven rent both pieces of equipment from the Authority as needed and use the trommel screen to increase the quality and value of compost sold by Lock Haven. Equipment and labor sharing should be incorporated into the compost operation. Provided there is sufficient area at Lock Haven's compost facility, it is suggested Lock Haven accumulate brush on site, and periodically rent the grinder from the Clinton County Solid Waste Authority for processing to allow Lock Haven to use and/or sell mulch.
- In the future, Lock Haven should sell finished compost and mulch and also charge tip fees for incoming loads if commercial vendors deliver to the site.
- When Lock Haven has a comfortable handle on operating the compost facility, it could identify vendors (e.g. landscapers) that can deliver truckloads of grass on a scheduled/managed basis. Adding nitrogen in the form of grass to leaf composting will

accelerate compost and improve the quality of the compost when grass is spread atop windrows and turned into windrows within 24 hours. Landscapers, or perhaps Lock Haven municipal crews/projects, could be a source for grass clippings.

- Submit for reimbursement through the Act 101, Section 902 Recycling Grant for any additional eligible recycling program and compost costs, including the outstanding cost balance for the recommended Case 721E, which is roughly \$40,000 more than the proposed Case 621D.

**APPENDIX A**

**Windrow Turner and Case Loader Equipment Specifications**



TS514



# Wildcat

## *Towable Straddle Compost Turner*



*Turns a 5' high x 14' wide windrow in a single pass!*

### **SPECIFICATIONS**

- 5' x 14' windrow capacity (single pass).
- Capacity: 2,300 tons per hour.
- 170 HP diesel engine.
- Windrow over 5,400 cubic yards per acre.
- Enclosed engine compartment helps keep radiator clear.
- Heavy-duty construction will provide years of reliable service.
- Fully mixes and completely aerates the windrow.
- Hitch folds hydraulically for ease of transport.
- Work platform around engine enclosure allows ease of maintenance.
- 4" x 12" flails, the heaviest on the market.
- Frame is heavy-duty 4" x 4" x ¼" structural tube.
- Weight: 13,200 lbs.
- 38" diameter drum (including flails) for increased tip speed.
- Can be towed with any 60 HP tractor.
- All functions are easily operated from control panel mounted on prime mover.
- One year parts and labor warranty.

# WILDCAT TS514

***No Creeper Gear Required!***



# TS514

## **Wildcat, the world's largest compost turner manufacturer.**

### **FEATURES**

- All control functions are operated from the drivers seat.
- Control panel is illuminated for night operation.
- Minimum 60 horsepower tractor (no creeper gear required).
- Belt and roller chain drive system for ease of maintenance.
- All roller chains are enclosed in an oil bath reservoir.
- No complex hydraulics or expensive gearboxes.



On the Wildcat TS514, the vertical adjustment on each side of the compost turner can be individually adjusted up to 24 inches. This allows the compost turner to adapt to site

conditions that previously have been unsuited for the majority of towable machines.



The aggressive Wildcat flails assure full windrow aeration.



Hitch folds hydraulically for ease of transport.

**Wildcat Manufacturing,  
the proven leader...we've  
been turning the heads of  
microbes around the world  
for over 25 years!**



# **Wildcat**

Box 1100, Freeman, South Dakota 57029 USA

800-627-3954 • (605) 925-4512

FAX: (605) 925-7536

Home page: [www.wildcatmfg.com](http://www.wildcatmfg.com)

**For more information please call:**



# 721E/XT

**ARTICULATED WHEEL LOADER  
TIER III CERTIFIED**

## ENGINE

Model	Case Family IV 667TA/EED, Tier III certified
Type	4-stroke, turbocharged and air-to-air cooled
Cylinders	6
Bore/Stroke	4.09 in x 5.20 in (104 X 132 mm)
Displacement	411 in <sup>3</sup> (6.7 L)
Fuel injection	Electronic
Fuel	#2 Diesel
Fuel filter	Replaceable, full flow spin-on cartridge
Fuel cooler	
Air filter	Dry type element w/warning restriction indicator
Mid-mount cooling module	External independent mounted coolers
Fan	
Style	8 blade puller
Diameter	32 in (813 mm)
Water pump	
Style	Integral
Engine oil	
Pump	Deep sump plate cooler with pressurized under-piston nozzles
Pump operating angle ratings	
Side-to-side	Rated 35°
Fore and aft	Rated 35°
Oil filtration	Replaceable, full flow spin-on cartridge
Engine speeds (rpm)	
Rated speed, full load	2000
Horsepower – Peak	
Max Power	
Gross	195 (145 kW) @ 2000 rpm
Net	183 (137 kW) @ 2000 rpm
Standard Power	
Gross	182 (136 kW) @ 1900 rpm
Net	172 (128 kW) @ 1800 rpm
Economy Power	
Gross	157 (117 kW) @ 1500 rpm
Net	149 (111 kW) @ 1500 rpm

NOTE: Gross horsepower and torque per SAE J1995.  
Net horsepower and torque per SAE J1349.

## ENGINE (CONTD.)

Torque – Peak		
Max Power		
Gross	636 lb-ft (862 N·m)@ 1400 rpm	
Net	605 lb-ft (821 N·m)@ 1400 rpm	
Standard Power		
Gross	625 lb-ft (847 N·m)@ 1400 rpm	
Net	596 lb-ft (809 N·m)@ 1300 rpm	
Economy Power		
Gross	614 lb-ft (832 N·m)@ 1200 rpm	
Net	590 lb-ft (800 N·m)@ 1200 rpm	
Torque rise		
Standard power @ 2000 rpm	31.4%	

## DRIVETRAIN

Transmission		
4F/3R Proportional w/Electronic Control Module torque sensing autoshift/manual shift and modulation		
Gears		
	Helical cut	
Gear ratios	Forward	Reverse
1st	3.745	3.551
2nd	2.089	1.981
3rd	1.072	1.017
4th	0.636	NA
Torque converter		
Stall ratio	2.81:1	
Differential		
	Limited slip on front and rear axles	
Rear axle oscillation		
	24° total	
Axles		
	Front	Rear
Differential ratio	3.364	3.182
Planetary ratio	6.000	6.400
Final axle ratio	20.18	20.36
Planetaries		
	Outboard	
Service brakes		
Hydraulically actuated, maintenance-free, multiple wet disc w/accumulator to all four wheels		
Brake surface area	480 in <sup>2</sup> per hub (0.31 m <sup>2</sup> )	
Parking brakes		
Spring-applied hydraulic release disc on transmission output shaft		
Travel speeds – mph (km/h) w/20.5x25 L3 Tires		
	Forward	Reverse
1st	4.7 (7.6)	5.0 (8.0)
2nd	8.3 (13.3)	8.7 (14.0)
3rd	15.3 (24.6)	16.0 (25.7)
4th	23.6 (38.0)	NA

NOTE: Travel speeds at full engine throttle.

## ELECTRICAL

Voltage	24 Volts, negative ground
Alternator	65 amp
Batteries	(2) 12-Volt

## HYDRAULICS

Pump (steering/implement)	
Closed centered pressure/flow compensated	
Variable displacement	
3.84 in <sup>3</sup> /rev 31.6 gpm @ 2000 rpm @ 3600 psi (119.6 L/min @ 2000 rpm @ 24 821 kPa)	
Implement pump	Closed centered pressure/flow compensated
Variable displacement	
2.74 in <sup>3</sup> /rev 22.6 gpm @ 2000 rpm @ 3600 psi (85.6 L/min @ 2000 rpm @ 24 821 kPa)	
Loader control valve	
Closed-center, sectional 2, 3 or 4-spool with pilot control for lift, tilt and auxiliary hydraulics, electromagnetic detents in float, raise and rollback	
Loader auxiliary steering	
Hydraulic orbital center-pivot articulating w/on-demand oil flow	
High pressure standby	3600 psi (24 821 kPa)
Filtration	
10-micron, full flow replaceable cartridges on return line, condition indicator light for filter	

## CYLINDERS

Lift cylinder	
Bore diameter	4.75 in (120.6 mm)
Rod diameter	3.00 in (76.2 mm)
Stroke	32.59 in (827.9 mm)
Dump cylinder (Z-Bar)	
Bore diameter	5.75 in (146.0 mm)
Rod diameter	3.00 in (76.2 mm)
Stroke	24.78 in (629.4 mm)
Dump cylinder (XT)	
Bore diameter	4.50 in (114.3 mm)
Rod diameter	2.25 in (57.2 mm)
Stroke	33.72 in (856.5 mm)

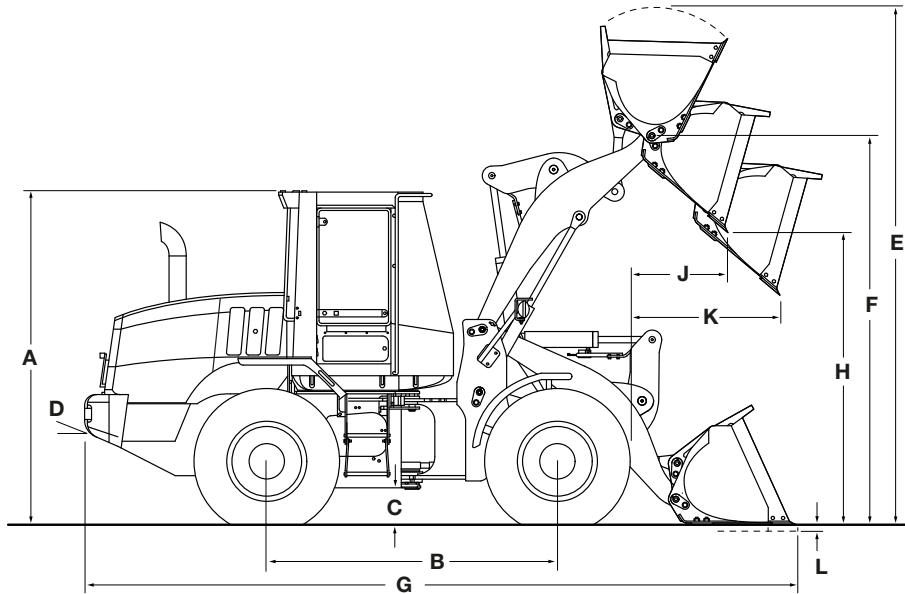

## DIMENSIONS

A.	Height to top of ROPS cab	134.0 in (3404 mm)
B.	Wheelbase	128.1 in (3253 mm)
C.	Ground clearance	14.4 in (365 mm)
D.	Angle of departure	32°
Width –		
	Overall* w/o bucket	100.9 in (2562 mm)
	Centerline tread	79.9 in (2029 mm)
	Turning radius* – outside	226.4 in (5750 mm)
Turning angle –		
	From center	40°
	Total angle	80°
	Rear axle oscillation, total	24°

NOTE: \*Dimensions taken with 20.5R25 Michelin XTLA tires. Additional dimensions on pages 3 & 4.

## WEIGHT ADJUSTMENTS

Select Options	Weight Adjustment	Tipping Load Adjustment Straight	Tipping Load Adjustment 40° Turn
20.5x25 12 ply L2 tires	-100 lb (-46 kg)	-82 lb (-37 kg)	-72 lb (-33 kg)
20.5x25 12 ply L3 tires	+228 lb (+103 kg)	+185 lb (+84 kg)	+163 lb (+74 kg)
20.5R25 XHA TL tires	+380 lb (+172 kg)	+309 lb (+140 kg)	+273 lb (+124 kg)
Standard counterweight	-1,224 lb (-555 kg)	-2,896 lb (-1314 kg)	-2,452 lb (-1112 kg)

NOTE: \*\*Unit equipped with Z-Bar loader arms, 3.0 yd3 (2.3 m3) general purpose pin on bucket w/bolt-on edge, 20.5R25 XTLA Michelin tires, ROPS cab with heater and air conditioner, full counterweight, standard batteries, front and rear fenders, full fuel and 175 lb (79 kg) operator. Adjust select options from rated weight.

## PERFORMANCE DATA

### 721E Z-Bar\*

	<b>3.5 yd<sup>3</sup> GP (2.70 m<sup>3</sup>) Bucket w/Bolt-on Edge</b>	<b>3.25 yd<sup>3</sup> GP (2.49 m<sup>3</sup>) Bucket w/Bolt-on Edge</b>
SAE bucket capacity – struck	3.01 yd <sup>3</sup> (2.30 m <sup>3</sup> )	2.76 yd <sup>3</sup> (2.11 m <sup>3</sup> )
Heaped	3.50 yd <sup>3</sup> (2.68 m <sup>3</sup> )	3.25 yd <sup>3</sup> (2.49 m <sup>3</sup> )
Bucket width – outside	106.3 in (2700 mm)	106.3 in (2700 mm)
Bucket weight	2,772 lb (1257 kg)	2,615 lb (1186 kg)
<b>E.</b> Operating height – fully raised w/spillguard	208.5 in (5297 mm)	205.8 in (5228 mm)
<b>F.</b> Hinge pin height – fully raised	156.6 in (3979 mm)	156.6 in (3979 mm)
<b>G.</b> Overall length – bucket level on ground	303.5 in (7710 mm)	301.2 in (7650 mm)
Dump angle – fully raised	55°	55°
<b>H.</b> Dump height – fully raised, 45° dump	113.7 in (2889 mm)	115.3 in (2927 mm)
<b>J.</b> Bucket reach – fully raised, 45° dump	46.1 in (1172 mm)	44.3 in (1126 mm)
<b>K.</b> Bucket reach – 7 ft 0 in (2.13 m) height, 45° dump	66.4 in (1688 mm)	65.3 in (1659 mm)
Operating load – ISO	11,967 lb (5428 kg)	12,036 lb (5459 kg)
Maximum material density – ISO	3,419 lb/yd <sup>3</sup> (2029 kg/m <sup>3</sup> )	3,702 lb/yd <sup>3</sup> (2196 kg/m <sup>3</sup> )
Tipping load – ISO		
Straight	27,616 lb (12 526 kg)	27,754 lb (12 589 kg)
40° turn	23,933 lb (10 856 kg)	24,072 lb (10 919 kg)
Lift capacity –		
Full height	16,005 lb (7260 kg)	16,162 lb (7331 kg)
Maximum reach	22,386 lb (10 154 kg)	22,551 lb (10 229 kg)
Ground	29,687 lb (13 466 kg)	29,992 lb (13 604 kg)
Breakout force w/tilt cylinder	29,805 lb (13 519 kg)	31,431 lb (14 257 kg)
Maximum rollback –		
Ground	40°	39°
Carry position	43°	43°
@ Maximum reach	54°	54°
@ Full height	57°	57°
<b>L.</b> Dig depth	3.0 in (76 mm)	3.0 in (76 mm)
Maximum grading angle w/bucket – back dragging	60°	60°
Loader clearance circle	498.9 in (12 671 mm)	497.5 in (12 636 mm)

### 721E/XT

	<b>3.0 yd<sup>3</sup> GP (2.3 m<sup>3</sup>) ACS Bucket w/Edge**</b>	<b>3.0 yd<sup>3</sup> GP (2.3 m<sup>3</sup>) ACS Bucket w/Teeth &amp; Segments**</b>
<b>E.</b> Operating height – fully raised w/spillguard	208.8 in (5305 mm)	208.9 in (5305 mm)
<b>F.</b> Hinge pin height – fully raised	156.5 in (3975 mm)	156.5 in (3975 mm)
<b>G.</b> Overall length – bucket level on ground	306.0 in (7773 mm)	311.8 in (7919 mm)
Dump angle – fully raised	52°	52°
<b>H.</b> Dump height – fully raised, 45° dump	112.1 in (2847 mm)	108.3 in (2751 mm)
<b>J.</b> Bucket reach – fully raised, 45° dump	47.8 in (1215 mm)	51.8 in (1317 mm)
<b>K.</b> Bucket reach – 7 ft 0 in (2.13 m) height, 45° dump	67.3 in (1709 mm)	69.4 in (1762 mm)
Operating load – ISO	11,128 lb (5048 kg)	11,147 lb (5056 kg)
Maximum material density – ISO	3,759 lb/yd <sup>3</sup> (2231 kg/m <sup>3</sup> )	3,766 lb/yd <sup>3</sup> (2235 kg/m <sup>3</sup> )
Tipping load – ISO		
Straight	25,783 lb (11 695 kg)	25,821 lb (11 712 kg)
40° turn	22,256 lb (10 095 kg)	22,295 lb (10 113 kg)
Lift capacity –		
Full height	15,042 lb (6823 kg)	15,077 lb (6839 kg)
Maximum reach	21,333 lb (9677 kg)	21,369 lb (9693 kg)
Ground	28,197 lb (12 790 kg)	28,259 lb (12 818 kg)
Breakout force w/tilt cylinder	28,770 lb (13 050 kg)	26,011 lb (11 798 kg)
Loader clearance circle	499.7 in (12 692 mm)	503.1 in (12 779 mm)

<b>3.25 yd<sup>3</sup> GP (2.49 m<sup>3</sup>) Bucket w/Teeth &amp; Segments</b>	<b>3.0 yd<sup>3</sup> GP (2.3 m<sup>3</sup>) Bucket w/Bolt-on Edge</b>	<b>3.0 yd<sup>3</sup> GP (2.3 m<sup>3</sup>) Bucket w/Teeth &amp; Segments</b>
2.76 yd <sup>3</sup> (2.11 m <sup>3</sup> )	2.53 yd <sup>3</sup> (1.94 m <sup>3</sup> )	2.53 yd <sup>3</sup> (1.94 m <sup>3</sup> )
3.25 yd <sup>3</sup> (2.49 m <sup>3</sup> )	3.01 yd <sup>3</sup> (2.30 m <sup>3</sup> )	3.01 yd <sup>3</sup> (2.30 m <sup>3</sup> )
107.7 in (2736 mm)	106.3 in (2700 mm)	107.7 in (2736 mm)
2,807 lb (1273 kg)	2,506 lb (1137 kg)	2,699 lb (1224 kg)
205.8 in (5228 mm)	203.4 in (5167 mm)	203.4 in (5167 mm)
156.6 in (3979 mm)	156.6 in (3979 mm)	156.6 in (3979 mm)
307.1 in (7801 mm)	299.1 in (7596 mm)	305.1 in (7749 mm)
55°	55°	55°
111.3 in (2828 mm)	116.6 in (2961 mm)	112.6 in (2861 mm)
48.5 in (1232 mm)	42.8 in (1087 mm)	46.9 in (1192 mm)
67.6 in (1717 mm)	64.3 in (1633 mm)	66.7 in (1694 mm)
11,918 lb (5406 kg)	12,067 lb (5474 kg)	11,950 lb (5420 kg)
3,665 lb/yd <sup>3</sup> (2175 kg/m <sup>3</sup> )	4,009 lb/yd <sup>3</sup> (2379 kg/m <sup>3</sup> )	3,970 lb/yd <sup>3</sup> (2356 kg/m <sup>3</sup> )
27,518 lb (12 482 kg)	27,812 lb (12 615 kg)	27,577 lb (12 509 kg)
23,836 lb (10 812 kg)	24,135 lb (10 947 kg)	23,900 lb (10 841 kg)
15,970 lb (7244 kg)	16,271 lb (7380 kg)	16,078 lb (7293 kg)
22,355 lb (10 140 kg)	22,665 lb (10 281 kg)	22,469 lb (10 192 kg)
29,790 lb (13 512 kg)	30,227 lb (13 711 kg)	30,023 lb (13 618 kg)
31,253 lb (14 176 kg)	32,958 lb (14 950 kg)	32,780 lb (14 869 kg)
40°	39°	40°
43°	43°	43°
54°	54°	54°
57°	57°	57°
3.3 in (84 mm)	3.0 in (76 mm)	3.3 in (84 mm)
61°	60°	61°
502.3 in (12 757 mm)	496.4 in (12 608 mm)	501.1 in (12 727 mm)

<b>3.0 yd<sup>3</sup> GP (2.3 m<sup>3</sup>) JRB Bucket w/Edge***</b>	<b>3.0 yd<sup>3</sup> (2.3 m<sup>3</sup>) JRB Bucket w/Teeth &amp; Segments***</b>
212 in (5384 mm)	212.0 in (5384 mm)
156.5 in (3976 mm)	156.5 in (3976 mm)
305.9 in (7770 mm)	311.9 in (7921 mm)
52°	52°
112.2 in (2850 mm)	108.3 in (2750 mm)
47.9 in (1217 mm)	52.1 in (1323 mm)
67.4 in (1713 mm)	69.6 in (1768 mm)
11,565 lb (5246 kg)	11,529 lb (5230kg)
3,907 lb/yd <sup>3</sup> (2318 kg/m <sup>3</sup> )	3,895 lb/yd <sup>3</sup> (2311 kg/m <sup>3</sup> )
26,790 lb (12 152 kg)	26,718 lb (12 119 kg)
23,131 lb (10 492 kg)	23,059 lb (10 459 kg)
15,135 lb (6865 kg)	15,077 lb (6839 kg)
21,506 lb (9755 kg)	21,448 lb (9728 kg)
29,144 lb (13 219 kg)	29,090 lb (13 195 kg)
28,740 lb (13 036 kg)	25,827 lb (11 715 kg)
500.3 in (12 706 mm)	503.8 in (12 797 mm)

NOTE: \*Z-Bar performance data shown w/full counterweight.  
 \*\*XT lift arm with buckets for ACS Pro Series 2000® size 30 HD coupler.  
 \*\*\*XT lift arm with buckets for JRB 500 HV coupler.

Performance data unit equipped with 20.5R25 Michelin XTLA tires, ROPS cab w/heater and A/C, full counterweight, standard batteries, front and rear fenders, full fuel and 175 lb (75 kg) operator. Specifications per SAE J732, J1234, J695, J742, and J818.

## INSTRUMENTATION

Electronic Information Center
Displays/Gauges –
Speedometer
Tachometer
Direction selected F/N/R
Transmission modes – Auto shift/Manual shift
Gear position
Engine coolant temperature
Fuel level
Transmission oil temperature
Hydraulic oil temperature
Hourmeter
Work mode
Indicator lights –
Low fuel
Turn signals
High beam lights
Grid heater*
Brake pressure
Master indicator
Secondary steering*
Parking brake
Audible alarms –
Caution alarm
Critical alarm
Backup alarm
Horn

NOTE: \*If equipped with option.

## OPERATOR ENVIRONMENT

ROPS cab w/ heat
Key start
Articulated power steering w/tilt column
Fully adjustable, suspension seat
Foot throttle
1-Lever loader control w/wrist rest
Cup holder
Coat hook
(1) Interior rearview mirror
2 in (51 mm) retractable seat belt
Storage tray behind seat
Cooled lunch box
Single brake pedal
F/N/R shuttle switch
External rear view mirrors
Lock box
Pressurized air filtering
Anti-glare window strip
Defroster
Side window, partial/fully open
Dome light
Wipers, rear and intermittent front
Windshield washers, front and rear
Rubber floor mat

## LOADER

Z-bar loader linkage
Single control for lift and tilt
Positive hold float
Automatic return-to-dig
Automatic height control
Automatic return-to-travel
Brake pedal transmission disconnect
Bucket position indicator on bucket

## CYCLE TIME

Raise w/rated bucket load	5.59 sec
Dump w/rated bucket load	
Z-Bar	1.8 sec
XT	1.9 sec
Lower (empty)	
Power down	3.29 sec
Float down	3.29 sec

## SERVICE CAPACITIES

Fuel tank	65 gal (246 L)
Hydraulic system	
Total	51.0 gal (193.1 L)
Reservoir	27.9 gal (105.7 L)
Transmission	
Service w/filter	6.75 gal (25.6 L)
Front and rear axle	
Front axle	32 qt (30.3 L)
Rear axle	29 qt (27.4 L)
Engine oil w/filter	15 qt (14.2 L)
Cooling system (-40)	39 qt (36.9 L)

## OPERATING WEIGHTS

### Z-Bar

Unit equipped with ROPS cab with heater and A/C, full counterweight, 20.5R25 XTLA Michelin tires, front and rear fenders, 3.0 yd<sup>3</sup> (2.3 m<sup>3</sup>) general purpose loader bucket w/edge, full fuel, 175 lb (79 kg)  
operator 30,644 lb (13 900 kg)

### XT

Unit equipped with ROPS cab with heater and A/C, full counterweight, 20.5R25 XTLA Michelin tires, 3.0 yd<sup>3</sup> (2.3 m<sup>3</sup>) ACS loader bucket, standard batteries, full fuel, 175 lb (79 kg)  
operator 31,827 lb (14 436 kg)

## STANDARD EQUIPMENT

### OPERATOR'S ENVIRONMENT

See page 5

### ENGINE

Case Family IV 667TA/EED  
Tier III certified  
Selectable work modes  
    Max power  
    Auto power  
    Standard power  
    Economy power  
Turbocharger  
Charge air cooling  
Automatic fan belt tensioner  
Integral engine oil cooling  
Fuel filter w/water trap  
Dual element air cleaner  
65 amp alternator  
(2) 700 CCA 12-volt batteries  
Liquid-cooled radiator  
Non spark-arresting muffler  
Mid-mounted cooling module  
Common rail electronic fuel injection

## OPTIONAL EQUIPMENT

### OPERATOR'S COMPARTMENT

Cloth-covered air-suspension seat  
Sound Shield noise suppression package  
Cab air-conditioning w/heater  
Radio  
Radio-ready (12 or 24-volt)  
Auxiliary power (12-volt)  
Cab convenience package  
RH steps and platform  
Rotating beacon  
Second brake pedal

### LOADER

See page 5

### DRIVETRAIN

4-wheel drive  
4F/3R Selectable autoshift/manual shift transmission  
Electronic Control Module – Programmable, computer controlled proportional shifting with programmable gear selection  
Onboard diagnostics  
Single lever electronic shift control  
F/N/R switch in loader control handle  
Downshift button  
Torque converter  
Outboard planetary axles  
Limited-slip differentials  
Transmission oil cooler  
Brake pedal transmission disconnect  
Hydraulic wet disc brakes  
Spring-applied hydraulic release parking brake  
Limp-Home Mode  
Lubed-for-life drive shaft

### ENGINE

Cold weather package  
    Heavy-duty batteries  
    Fuel heater  
    Hydraulic oil cooler bypass  
    Low temperature hydraulic oil  
    Grid heater

### LOADER

Hydraulic attachment coupler  
Attachment auxiliary hydraulics  
Buckets (see page 3 & 4)  
Loader coupler systems  
XT Linkage

### HYDRAULICS

Auxiliary hydraulics  
Ride Control  
Secondary steering  
3 or 4-spool loader valves with 2 or 3-lever loader control  
Hydraulic reversing fan  
Hydraulic cooler

### HYDRAULICS

Single lever 2-spool loader control valve  
Low-effort steering  
Hydraulic driven fan  
(8) Diagnostic quick couplers

### OTHER

Electric hood lift  
Front and rear fenders  
Lights –  
    (2) Front driving headlights (high/low beam)  
    (2) Front flood  
    (2) Stop/tail lights and backup light  
    (2) Rear flood  
    Front and rear turn signal/flash  
Standard counterweight  
Drawbar hitch  
Articulation locking bar  
Lift arm locking bar  
Lift and tie-down points – front/rear  
Backup alarm  
Remote drain points

### TIRES

20.5-25 12 PR L3 bias (rock)  
20.5 R25 radial (dirt/traction)  
20.5 R25 radial (rock)

### OTHER

Special paint  
Full coverage fenders  
Belly pan  
Tool box  
Full counterweight - Z-Bar  
Temperature controlled fan

NOTE: All specifications are stated in accordance with SAE Standards or Recommended Practices, where applicable.

NOTE: All engines meet current EPA emissions requirements.

IMPORTANT: CNH America LLC reserves the right to change these specifications without notice and without incurring any obligation relating to such change. CNH America LLC does not warrant the safety or reliability of attachments from other manufacturers.

Case is a registered trademark of CNH America LLC. Any trademarks referred to herein, in association with goods and/or services of companies other than CNH America LLC, are the property of those respective companies.



[www.casece.com](http://www.casece.com)