

DRAFT
TIMBER HARVEST OPERATIONS
FIELD GUIDE
FOR WATERWAYS, WETLANDS
AND EROSION CONTROL



The Commonwealth of Pennsylvania
Department of Environmental Protection
Bureau of Clean Water
and
Bureau of Waterway Engineering and Wetlands
Harrisburg, Pennsylvania



This publication resulted from the joint efforts of the Bucks, Cambria, Cumberland, Wayne and Westmoreland County Conservation Districts, Pennsylvania Sustainable Forestry Initiative (SFI) Implementation Committee, Pennsylvania Association of Conservation Districts (PACD), Pennsylvania Game Commission, Pennsylvania Forest Products Association, DCNR Bureau of Forestry, Department of Environmental Protection (DEP) Bureau of Clean Water and DEP Bureau of Waterways Engineering and Wetlands.

This publication replaces the previous two publications entitled:

"Best Management Practices for Silvicultural Activities in Pennsylvania's Forest Wetlands", a pocket guide for foresters, loggers, and other forest land managers, prepared by the Forested Wetlands Task Force, May 1993; and

"Controlling Erosion and Sediment from Timber Harvest Operations", publication 3930-BK-DEP2322, Revised 4/2003.

For additional information refer to DEP's Erosion and Sediment Pollution Control Program Manual (DEP Document #363-2134-008, March 2012) (E&S Manual). Where information differs from this document and the E&S Manual, the information in the E&S Manual will prevail. Additional approved best management practices (BMPs) and specifications can be found on DEP's website, www.dep.pa.gov/constructionstormwater (select E&S Resources).

Disclaimer

This Timber Harvest Operations Field Guide has been published by DEP as a quick reference guide and contains the most commonly used BMPs for silviculture activities and considerations for conducting silviculture activities that impact streams and their floodways or wetlands. This field guide is not intended as a substitute for and does not supplant the rules and regulations of the Commonwealth of Pennsylvania.

CONTENTS

I. PURPOSE	6
II. RELEVANT FEDERAL AND STATE LAWS	6
A. Pennsylvania Clean Streams Law (Act 394 of 1937)	6
1. 25 Pa. Code Chapter 93	6
2. 25 Pa. Code Chapter 102	7
3. 25 Pa. Code Chapter 105	7
B. Pennsylvania Natural Diversity Inventory (PNDI) Environmental Review	10
C. Municipal and County Notification Requirement	10
D. Fish and Boat Code – Act 175	11
E. Federal Clean Water Act	11
1. National Pollutant Discharge Elimination System (NPDES)	11
2. Pennsylvania State Programmatic General Permit (PASPGP)	11
III. SITE PLANNING	12
A. Soil Considerations	12
1. Erosion Hazard	12
2. Soil Drainage	12
B. Water Considerations	13
1. Designated and Existing Uses	13
2. Streams and Stream Crossings	14
3. Wetlands and Wetland Crossings	15
C. Site Layout	24
1. Haul Roads	26
2. Skid Roads and Skid Trails	27
3. Log Landings	27
4. Pollution from Geological Formations	28
5. Thermal Impacts to Surface Waters	28
IV. SITE MANAGEMENT	29
A. BMP Responsibility	29
B. Recommended BMPs	29
1. Ditch Relief Culvert (Cross Drains)	30
2. Waterbars	31
3. Turnouts	33
4. Water Deflector	33
5. Broad-based Dips	35
6. Filter Strip	36
7. Silt Fence (Filter Fabric Fence)	37
8. Compost Filter Sock	38
9. Straw Bale Barrier	39

10.	Wood Chip Filter Berm.....	40
11.	Rock Construction Entrance	41
12.	Disturbed Area Stabilization.....	42
C.	Site Maintenance	44
D.	Winter Harvests	45
V.	SITE RETIREMENT	45
	APPENDIX A: Checklist for Wetlands Protection	47
	APPENDIX B: List of Common Pennsylvania Wetland Plants	48
	APPENDIX C: Contact Information	50
	APPENDIX D: Matrices for Calculating Acres of Disturbance	52
	APPENDIX E: Key Federal Regulations for Section 404 of the Clean Water Act	54
	ACRONYMS	55
	REFERENCES	56

DRAFT

LIST OF TABLES

- Table 1. Descriptions and Use Limitations of Soil Drainage Classes
- Table 2. Ditch Relief Culvert Spacing for Temporary Access Roads
- Table 3. Ditch Relief Culvert Spacing for Permanent Access Roads
- Table 4. Waterbar Spacing
- Table 5. Water Deflector Spacing
- Table 6. Broad Based Dip Spacing
- Table 7. Filter Strip Widths
- Table 8. Recommended Seed Mixtures
- Table 9. Recommended Seed Mixtures for Stabilizing Disturbed Areas

LIST OF FIGURES

- Figure 1. Typical Tire Mat Wetland Crossing
- Figure 2. Typical Expanded Metal Grating Wetland Crossing
- Figure 3. Typical Wood Mat for Wetland Crossing
- Figure 4. Typical Timber Harvest Site Plan
- Figure 5. Alternative Timber Harvest Site Plan
- Figure 6. Standard Construction Detail for Ditch Relief Culvert
- Figure 7. Standard Construction Detail for Waterbars
- Figure 8. Standard Construction Detail for Turnouts
- Figure 9. Standard Construction Detail for Water Deflectors
- Figure 10. Standard Construction Detail for Broad-based Dips
- Figure 11. Standard Construction Detail for Filter Strips
- Figure 12. Standard Construction Detail for Silt Fence
- Figure 13. Standard Construction Detail for Compost Filter Sock
- Figure 14. Standard Construction Detail for Straw Bale Barriers
- Figure 15. Standard Construction Detail for Wood Chip Filter Berm
- Figure 16. Standard Construction Detail for Rock Construction Entrance

I. PURPOSE

The purpose of this publication is to assist landowners, foresters, and loggers to prepare and implement erosion and sediment control (E&S) best management practices (BMPs) for sites that do not require a written E&S Plan, and to develop and implement E&S Plans where required. Additionally, this publication is intended to provide guidance when seeking to conduct timber harvesting and related activities in and around streams and wetlands. Experience has shown that most erosion problems on timber harvesting activities originate with the improper layout or construction of skid trails, logging roads, landing areas, and stream/wetland crossings. Additional concerns may arise as a result of inclement weather and freeze thaw cycles. Therefore, the focus of this publication is to provide guidance and furnish specifications to properly design and implement effective E&S BMPs and stream and wetland crossings on a timber harvesting site.

When using this publication, it is important to remember that for every situation described, there may be more than one correct method to minimize erosion and prevent sediment pollution.

II. RELEVANT FEDERAL AND STATE LAWS

Both state and federal laws address earth disturbance activities which have the potential to affect water quality and discharge pollutants into waters of the Commonwealth. These laws include sections 401 and 404 of the Clean Water Act (33 U.S.C. §§ 1341 and 1344), The Clean Streams Law (35 P.S. §§691.1-691.1001), Dam Safety Encroachments Act (32 P.S. §§ 693.1-693.27) and the regulations thereunder. Persons proposing or conducting timber harvesting activities in the Commonwealth of Pennsylvania should be familiar with these laws and regulations.

A. Pennsylvania Clean Streams Law (Act 394 of 1937)

Many of Pennsylvania's water quality regulations are issued under the authority of The Clean Streams Law and are enforced by DEP. The Clean Streams Law is the main law designed to protect Pennsylvania's water resources and sets forth the legal framework intended to "preserve and improve the purity of the waters of the Commonwealth." DEP's regulations, set forth in the Pennsylvania Code, implement the Clean Streams Law. Timber harvesting activities must be done in conformance with the applicable federal and state laws, including sections 401 and 404 of the Clean Water Act, The Clean Streams Law, Dam Safety and Encroachments Act and the regulatory requirements of Title 25, Chapters 93, 102 and 105.

1. 25 Pa. Code Chapter 93

Under Chapter 93, DEP sets water quality standards for Pennsylvania's surface waters, including wetlands. These standards are used to assess whether Pennsylvania's surface waters are capable of supporting different water uses such as fish and other aquatic life, recreation, water supply for drinking, agriculture and industry, and other protected uses. All surface waters in Pennsylvania are classified based on their designated use and associated water quality criteria under Chapter 93. Surface waters may also have an existing use classification that reflects the use they are actually attaining. The designated and existing uses assigned to Pennsylvania's surface waters can affect their regulatory protection and permitting requirements. Both designated and existing uses are equally protected when DEP issues a permit or approval for an activity which may impact the surface water's use (i.e., if either use classification has higher protection requirements, those requirements would apply). Particular attention should be paid to special protection waters that are designated as High Quality Waters (HQ) or Exceptional Value Waters (EV). For more information see DEP's *Water Quality Antidegradation Implementation*



DEP's Water Quality Antidegradation
Implementation Guidance

Guidance (DEP Document #391-0300-002, November 2003). Timber harvesting operations comply with Chapter 93 through implementation of E&S BMPs under Chapter 102.

2. 25 Pa. Code Chapter 102

In Pennsylvania, all earth disturbance activities must be undertaken in accordance with DEP's Chapter 102 regulations. Under these regulations, all earth disturbance activities, regardless of size or extent, are required to implement and maintain E&S BMPs to minimize the potential for accelerated erosion and resulting sedimentation to waters of the Commonwealth. Timber harvesting is considered an earth disturbance activity under Chapter 102 because the operations involved in moving the product from the stump to the mill disturbs the forest floor and exposes soils to accelerated erosion. While the felling of trees itself does not create an earth disturbance, the activities involved in moving the product from the stump to the mill may cause erosion and sediment pollution.



Chapter 102 Regulations

When planned disturbances total 5,000 square feet or more, or has the potential to discharge to a special protection surface water (under Chapter 93), DEP's regulations require that a written E&S Plan must also be developed and kept on-site at all times (25 Pa. Code § 102.4(b)(2)). Additionally, a written E&S Plan must be developed if required under another regulation. Typically, the earth disturbance activity for a timber harvesting activity includes the haul roads, landings, and skid trails.

DEP's eMAP tool (<http://www.depgis.state.pa.us/emappa/>) and Existing Use Classification list (visit www.dep.pa.gov and search for "Existing Use Classifications") can be used to identify special protection surface waters. Additionally, EV wetlands are defined at 25 Pa. Code § 105.17(1). DEP offers a standard E&S Plan Template for Timber Harvesting Operations that satisfies Chapter 102 requirements (DEP Document ID# 3800-FM-BCW0539). The matrices in Appendix D of this guide can be used to help estimate the anticipated amount of disturbance for a timber harvesting activity.



DEP's eMAP tool



DEP's Existing Use List

DEP's regulations require timber harvesting activities that will disturb 25 acres or more to obtain an E&S Permit (25 Pa. Code § 102.5(b)). All necessary permits must be obtained prior to beginning any earth disturbance activity. Inquiries as to whether or not a permit is required should be addressed to the local county conservation district or DEP Regional Office.

3. 25 Pa. Code Chapter 105

Activities associated with timber harvesting operations are also governed by DEP's Chapter 105 Dam Safety and Waterway Management regulations adopted under the provisions of the Clean Streams Law, Dam Safety and Encroachments Act, and the Floodplain Management Act (32 P.S. §§ 679.101—679.601). Chapter 105 regulations govern the crossing of streams and their floodways, wetlands and other bodies of water. Bridges, culverts, fills,

walls, embankments, other structures, and activities which change the course, current, or cross section of a stream, floodway, wetland, or body of water are regulated by Chapter 105. Most structures and activities in Pennsylvania waterways (dams, water obstructions and encroachments) require some type of authorization or permit from DEP to protect public health, safety and the environment.

The following is a partial list of activities that may require permits from DEP:

- Permits are required for deposition of solid fill, gravel, soil, slate and other such material in wetlands, streams and floodways for the construction of temporary and permanent roads. Fill material will be required to be “clean” or washed stone or gravel depending upon permit conditions. Note: Clean stone is required in the conditions of General Permit 8.
- Permits are required for construction, operation, maintenance and modification, enlargement or abandonment of any dam, water obstruction or encroachment (i.e., culverts, fills, ditching).
- Permits are required to clear and grub, dig ditches and conduct other similar activities in wetlands. This includes activities that would alter the course, current or cross section through rutting.
- Permits are required for constructing roads, whether temporary or permanent, in or across streams and their floodways and wetlands.
- Permits are required to place support mats, corduroy and other temporary fabricated roads in wetlands for use as haul roads or skid trails.
- Permits are required to deposit fill for skid trails in or across streams and their floodways and wetlands.
- Applicants may need to obtain a submerged lands license during the Chapter 105 permit process if their timber harvesting activities would occupy submerged lands of the Commonwealth.

Permits are not required to hand fell timber and other vegetation, including cutting in wetlands, as long as activity does not cause earth disturbance or change wetland hydrology.

There are three levels of permitting provided by Chapter 105: waiver of permit requirements, general permit coverage, and issuance of a Chapter 105 Water Obstruction and Encroachment Permit. If the activity is not waived it may qualify for General Permit Coverage. General Permits have been issued for similar types of activities and contain specific conditions and limitations. If the regulated activity does not qualify for these, then an individual permit is required.

Chapter 105 Waivers and Timber Harvest

Some regulated structures and activities have the requirement to obtain a permit waived in the regulations (25 Pa. Code § 105.12(a)). *Most* waived structures and activities do not require notification or approval to DEP. Waived structures and activities are still subject to compliance with the Dam Safety and Encroachments Act and Chapter 105 regulations. The most common waiver utilized in timber harvest operations is the installation of a temporary or permanent stream crossing in a stream or floodway with a drainage area of less than 100 acres. This activity does not require a Chapter 105 permit if the crossing will not impact a wetland (Wetland impacts require a permit). See 25 Pa. Code § 105.12(a)(2). Note that wetlands are often located in the floodways adjacent to headwater streams. Also, even though the stream crossing may not require a permit, sediment pollution and encroachments are still regulated, and the crossing may still require federal authorization from the US Army Corps of Engineers (USACOE, refer to PASPGP below). The installation of a temporary or permanent stream crossing in a stream or floodway with a drainage area of 100 acres or more requires a Chapter 105 Water Obstruction and Encroachment permit.

Chapter 105 General Permits and Timber Harvest

Projects that qualify for General Permit coverage are now available as online electronic permit applications through DEP's e-permitting system:

<https://www.dep.pa.gov/Business/Water/Waterways/Pages/ePermitting.aspx>.

Upstream drainage area is determined from the location of the proposed stream crossing and can be determined from the United States Geological Survey (USGS) StreamStats web application using the delineate tool (<https://streamstats.usgs.gov/ss/>). Once a basin is delineated to a precise point on a stream network is completed, click continue and then select the drainage area field (DRNAREA) from the basin characteristics options and then continue to see the basin area in square miles. There are 640 acres in a square mile. In reference to a stream crossing qualifying for the waiver under 25 Pa. Code § 105.12(a)(2), a basin drainage area result of 0.15 square miles (96 acres) or less would qualify.



Ch. 105 e-permitting



USGS Stream Stats

Many projects qualify for a simple Water Obstructions and Encroachment general permit registration if they can be designed and implemented in accordance with the criteria in the general permit. Each general permit contains specific conditions (i.e. size of structure, drainage areas, time of year restrictions, considerations for species of special concern, etc.) that must be followed by the applicant. Each general permit application includes a full listing of these conditions. The general permits most often used in timber harvesting activities

include General Permit 7 (GP-7) for Minor Road Crossings and General Permit 8. (GP-8) for Temporary Road Crossings.

Temporary crossings on non-public roads that will be used no longer than one year can generally be permitted through GP-8. This permit allows streams to be crossed using a culvert, a series of culverts, a bridge or a ford. The purpose of the permit is to facilitate completion of temporary projects, such as a timber harvest, that can be completed in one year or less. Temporary crossings must be restored at the end of their use in accordance with the requirements of the permit. Note that the permit application identifies a number of restrictions where the GP-8 cannot be applied. Information and applications for GP-8 may be obtained from any conservation district office or online at DEP's [eLibrary](#).



Ch. 105 Application Forms on eLibrary

Minor (permanent) crossings of streams that have an upstream watershed drainage area of one (1) square mile or less or wetland crossings that disturb less than one-tenth (0.1) of an acre and that are not designated EV or floodways delineated by the Federal Emergency Management Agency (FEMA) can generally be permitted through GP-7. All wetlands impacted through the use of the GP-7 must be replaced. The replacement, in accordance with the definition of mitigation in 25 Pa. Code § 105.1, can be adjacent to or in the immediate proximity of the minor road crossing and at a ratio of 1:1 for area, function and value. See also, 25 Pa. Code § 105.20a. Mitigation will also generally require monitoring for a period of five years to determine success. Other options available for mitigation are credits purchased through an approved In-lieu fee program or a mitigation bank if one is available in the watershed area of the impact. Note that the permit application identifies a number of additional restrictions where the GP-7 cannot be applied. Information and applications for GP7 may be obtained from any conservation district office or online at DEP's [eLibrary](#).

Individual Water Obstruction and Encroachment Permit

Structures and activities that do not qualify for a permit waiver or a general permit must obtain a Chapter 105 Water Obstruction and Encroachment Permit from DEP. The application serves

as a joint application for the Chapter 105 Water Obstruction and Encroachment Permit and when applicable, the federal Section 404 permit (Clean Water Act) issued by the USACOE (refer to PASPGP below). Currently, most activities qualify for inclusion and are not forwarded to the USACOE for independent review. In this case the PASPGP federal authorization would be attached to the Chapter 105 Water Obstruction and Encroachment Individual Permit upon issuance from DEP. Should a separate federal review be required USACOE, the applicant would be notified by DEP and/or USACOE concerning the additional processing and information required for the review and/or issuance of a federal Section 404 permit by the USACOE. Work may not begin until both the state and federal authorizations are received. DEP has two types of joint permit applications – Small Projects and Standard. A Small Projects Application may be made for projects in streams and floodplains where insignificant impacts on safety and protection of life, health, property and the environment can be demonstrated without detailed studies or engineering calculations. For all other projects, including those projects affecting wetlands and those projects where safety and environmental impacts must be determined through technical studies, a Standard Application must be submitted to DEP. Either type of application can be made using the Joint Permit Application forms, found on DEP's [eLibrary](#).

Chapter 105 permits, including general permits, are issued with the provision that adequate E&S control measures will be implemented by the permittee. It is imperative that operators always implement and maintain adequate E&S controls and comply with Chapter 102 of DEP's regulations.

Refer to Section II.B.3. of this guide for additional details on wetland crossings. All necessary permits must be obtained before the timber harvesting activity can begin. Questions about permit requirements should be addressed to DEP's Regional Office Waterways and Wetlands permitting section or a Chapter 105 delegated county conservation district office.



25 Pa. Code
Chapter 105

B. Pennsylvania Natural Diversity Inventory (PNDI) Environmental Review

Chapter 102 and 105 permits require the protection of State and Federal threatened and endangered (T&E) species on a project site. In addition, permit applicants may have to address potential impacts to Species of Special Concern. Permit applicants must coordinate with the Pennsylvania Natural Heritage Program (PNHP) to search for and address any potential impacts to T&E species. The online Pennsylvania Natural Diversity Inventory (PNDI) Environmental Review tool available through the Pennsylvania Conservation Explorer website (<https://conservationexplorer.dcnr.pa.gov/>) is the most efficient means of conducting this screening in a timely manner. Upon completion, a PNDI receipt, valid for a period of two years from the date the search was conducted, is automatically available for printing. To provide proof of coordination with PNHP and PNDI, applicants must submit a signed PNDI receipt as part of the permit application.



PNDI Review

Early coordination (prior to permit application), by prospective applicants and their consultants with the appropriate jurisdictional agencies is the most effective means of a timely permit decision. If the review determines there are potential impacts to a T&E species, the PNDI receipt will provide an explanation of the potential impact(s) and instructions on how to resolve the potential impact(s). Read and follow these instructions carefully.

C. Municipal and County Notification Requirement

Act 14 of 1984 requires that applicants for Chapter 102 and 105 permits give written notification to each local municipality and county in which the permitted activity is located. Acts 67, 68 and 127 of 2000 amended the Municipalities Planning Code to provide new tools for local governments to plan for and manage growth by directing state agencies to consider and in some cases rely upon

comprehensive plans and zoning ordinances when reviewing applications for the permitting of infrastructure or facilities. DEP may not issue a permit or authorization until 30 days after the municipality and county government in which the activity is located have received the required written notices.

Chapter 102 and 105 permit applicants are therefore required to notify local governments of planned land development activities and to provide local governments the opportunity to identify any land use planning or zoning ordinance conflicts associated with the proposed project before DEP or a delegated county conservation district completes its review of the NOI/permit application.

Municipal notification requirements for Chapter 105 General Permits are different than other permit types. The instructions for the notification can be found in the General Permit Registration Instructions, located in DEP's [eLibrary](#).

Municipal and county notification is not required if Chapter 102 or 105 permitting is not needed for the timber harvesting activity.

D. Fish and Boat Code – Act 175

The Fish and Boat Code is administered by the Pennsylvania Fish and Boat Commission and regulates the impact of man-made alterations or activities on waters of the Commonwealth, and prohibits the introduction of any substance harmful to aquatic life. Particularly relevant sections include §§ 2502, 2503, and 2504. See:

<https://www.legis.state.pa.us/WU01/LI/LI/CT/HTM/30/30.HTM>.



PA Fish & Boat Code

E. Federal Clean Water Act

The Clean Water Act (CWA) is the primary Federal law that protects the health of our nation's waters, including lakes, rivers and coastal areas. It regulates discharges of pollutants into waters of the United States and regulates quality standards for surface waters. The CWA is jointly enforced by the United States Environmental Protection Agency (EPA) and the USACOE. See:

<https://www.epa.gov/laws-regulations/summary-clean-water-act>.



Clean Water Act (EPA)

1. National Pollutant Discharge Elimination System (NPDES)

Section 404 of the CWA establishes a program to regulate the discharge of dredged or fill material into waters of the United States, including wetlands. Section 402 of the CWA establishes a program to regulate the point source discharge of pollutants into waters of the United States. Silvicultural activities are exempt from the National Pollutant Discharge Elimination System (NPDES) permit process under section 402 of the CWA in areas where a federal section 404 authorization has been issued if there is no discharge of dredged or fill material that contains toxic pollutants and no conversion of a wetland to a non-wetland (refer to Appendix E of this guide).

2. Pennsylvania State Programmatic General Permit (PASPGP)

The Pennsylvania State Programmatic General Permit (PASPGP) is an authorization that the USACOE has granted DEP the authority to provide in conjunction with the General Permits associated with the Water Obstructions and Encroachment Permits under Chapter 105. The PASPGP allows for a streamlined permitting process for eligible structures and activities that eliminates the need for redundant federal reviews and processing for certain qualifying projects

and ensures compliance with federal regulations such as the federal Clean Water Act, Rivers and Harbors Act of 1899, Endangered Species Act, the National Historic Preservation Act, and the Magnuson-Stevens Fisheries Conservation and Management Act.

III. SITE PLANNING

Careful planning of timber harvesting activities to control erosion and sedimentation, avoid wetland and stream crossings, and minimize impacts where practicable is essential to ensuring that all planned water quality protection measures are practical and effective.

Timber harvesting activities undertaken without planning can produce undesirable environmental, economic, and aesthetic consequences. Using available topographic maps, soil surveys, and aerial imagery in combination with local knowledge or field reconnaissance/survey can help identify problematic site conditions and allow for the development of an effective E&S Plan for protecting soil and water resources and other sensitive environmental areas from adverse impacts during the operation.

A. Soil Considerations

Consideration of soil type is important when designing road systems. Soils vary in their ability to absorb stormwater, maintain structure, or resist erosion and compaction.

General soil information and soil surveys are available online using the NRCS Web Soil Survey (<https://websoilsurvey.sc.egov.usda.gov/App/>). The soil survey contains specific information on soil types and soil features, such as drainage and suitability for road base, that may affect road location and construction.



NRCS Web Soil Survey

DEP regulations in Chapter 102 require that timber harvesting E&S Plans must identify the types, depths, slope, locations, and limitations of the soils (25 Pa. Code § 102.4(b)(5)(ii)). This includes a soil map that shows the location of the soils across the project area.

1. Erosion Hazard

Soil erosion is one of the most serious environmental problems affecting the quality of soil, land, and water resources. While erosion is a natural process, accelerated erosion that occurs at a greater rate than normal as a result of earth disturbance activities conducted during a timber harvesting activity can degrade site productivity and lead to sedimentation. Soil erosion hazard is an estimate of how easily soil particles can be detached from the soil surface. Soils classified as slight are likely to have little or no erosion. Soils classified as moderate will likely have some soil erosion and haul roads and skid trails will require simple erosion-control measures and occasional maintenance. Soils classified as severe indicate that significant erosion is expected. Soils with a moderate or severe erosion hazard are poor choices for log landing and road locations, and, if possible, alternatives should be considered.

2. Soil Drainage

Soil drainage is one of the most significant considerations in road construction. Soils classified as somewhat poorly drained to very poorly drained often cause problems because they may not support the weight of logging equipment during periods of soil saturation. BMP implementation is usually required to prevent degradation of the road, erosion of these soils, and to maintain operability of the job. Poorly drained and very poorly drained soils cause problems during wet periods and very often contain wetlands (See **Table 1**). In addition to soil drainage characteristics, the soil's hydric soil status can also be used to indicate when wetlands may be present on the site.

Surface features, such as stones, should not be used as indicators of soil drainage. Several soil types in Pennsylvania appear from surface features to be well drained, when in fact, they are not. The extent and types of soils encountered on a logging site can be highly variable. The timber harvester must recognize the capabilities of a soil and be prepared to adjust the road design during construction to avoid problem areas, especially near streams, wetlands, floodways and floodplains.

Table 1. Descriptions and Use Limitations of Soil Drainage Classes

Drainage Class	Description	Degree of Limitation*
Well Drained	Water is removed readily from the soil. Wetness does not inhibit plant growth. Commonly medium textured.	Slight
Moderately Well Drained	Water is removed slowly from the soil during some periods. Wet for only short periods during the growing season, but periodically long enough to affect most dry site plants.	Slight
Somewhat Poorly Drained	Water is removed slowly enough that soil is wet for significant periods during the growing season.	Moderate
Poorly Drained	Water is removed so slowly that the soil is saturated periodically during the growing season or remains wet for long periods. Free water commonly at or near the surface.	Severe
Very Poorly Drained	Water is removed from soil so slowly that free water remains at or on the surface during most of the growing season. Very poorly drained soils are found in level or depressed areas and are frequently ponded.	Severe

*Slight – indicates that use of equipment may not be limited to a particular kind of equipment or time of year.

Moderate – indicates a short seasonal limitation or a need for some modification in management or equipment.

Severe – indicates a seasonal limitation, a need for special equipment or management, or a hazard in the use of equipment.

B. Water Considerations

All surface waters, including lakes, ponds, streams, floodways, and wetlands, whether natural or artificial, in Pennsylvania are protected waters of the Commonwealth. It is illegal to damage wetlands or to allow eroded sediment from earth disturbance activities to enter streams and lakes without authorization from DEP or in compliance with DEP regulations. Certain activities may require permits from DEP and nearly all timber harvest operations require a written E&S Plan.

1. Designated and Existing Uses

Timber harvesting E&S Plans must identify the name and designated and existing uses for surface waters, including wetlands, which may receive runoff within or from the timber harvest's project site (refer to Section II.A.1 of this guide) (25 Pa. Code § 102.4(b)(5)(v)). Designated uses for waters of the Commonwealth are found in [25 Pa. Code §§ 93.9a-z](#). See:

<http://www.pacodeandbulletin.gov/Display/pacode?file=/secure/pacode/data/025/chapter93/s93.9.html&d=reduce>.

Existing uses are found on [DEP's website](#) (visit www.dep.pa.gov and search for "Existing Use Classifications").



Ch. 93
Regulations



DEP Website
Keyword Search:
"Statewide Existing Use"

2. Streams and Stream Crossings

A stream is any channel having defined bed and banks, whether natural or artificial, with perennial or intermittent flow of surface water. Perennial streams normally flow throughout the year, whereas intermittent streams normally flow in the wetter parts of the year (i.e., October through May) or after a major storm.

Stream crossings are a major concern in the construction and use of haul roads, and skid trails. The potential for sediment to enter a stream at crossing points is great. It is always best to avoid crossing a stream or wetland if an alternate location is possible. Timber harvesting E&S Plans should identify the planned location of all stream and wetland crossings and all appropriate permits must be obtained prior to constructing any crossings (refer to Section II of this guide).

Pay attention to both stream and road alignment when selecting the site for a stream crossing. The road should cross the stream at right angles. Ideally, the streambed should be narrow and straight with even banks so as not to obstruct the flow of water. Approach the stream at as gentle a slope as possible. Maintain all stream approaches in a firm and stable condition and direct any runoff to a sediment removal area (e.g. filter strip, straw bale, silt fence, sump, or trap for treatment). Waterbars and/or broad-based dips should be installed and maintained as required on the approaches to the stream crossing (refer to Section IV.B of this guide).

Portable bridges are perhaps the most common method of temporary crossing streams. They can span a stream without inhibiting streamflow or aquatic movement and can be installed without extensive soil backfill, thereby reducing impacts to water quality.

Culverts used in temporary stream crossings should be appropriately sized (i.e. provide a waterway area sufficient to adequately discharge the normal flow of the watercourse or stream, and shall be of sufficient length to extend beyond the toe of the clean rock fill) and placed in the natural drainage channel on the same grade as the streambed. Temporary stream crossing culverts should be installed with clean rock material. It is important to ensure that temporary stream crossings are kept open and functioning by keeping them free of debris and other obstructions.

Fords are sometimes used for haul road stream crossings, but they are not acceptable for skid roads or trails. When skid roads or trails must cross streams, culverts or portable bridges can be used. Temporary fords can typically be authorized utilizing General Permit 8 (Temporary Road Crossings). Stream sections suitable for ford crossings must have low banks and solid streambeds. If the streambed at the site of a ford crossing does not have a rock bottom, provide

a layer of clean rock, taking care not to obstruct the streamflow. GP-8 cannot be used to authorize ford crossings in High Quality (HQ) or Exceptional Value (EV) streams. For specific design information, refer to GP-8 Design and construction criteria are different for permanent stream crossings. Refer to the conditions and limitations of General Permit 7 (Minor Road Crossings) to see the limitations and use of this general permit. If a permanent stream crossing cannot meet these terms and conditions, an individual water obstruction and encroachment permit is required.



25 Pa. Code 105.1

The floodways of streams are also regulated under Chapter 105. Regulated floodways are as indicated on FEMA mapping or, if not indicated, it is assumed to be 50 feet from the top of bank landward, absent evidence to the contrary ([See 25 Pa. Code 105.1](#)). Place landings as far from streams and wetlands as possible (within 50 feet of stream or within FEMA floodway requires Chapter 105 permitting action by DEP).

3. Wetlands and Wetland Crossings

In order to avoid confusion, the term *wetlands* has been given a specific legal definition in both federal and state law. Wetlands are defined under Section 404 of the Federal Clean Water Act and Chapter 105 regulations issued pursuant to Pennsylvania's Dam Safety and Encroachments Act as:

Areas that are inundated or saturated by surface water or groundwater at a frequency and duration sufficient to support, and that under normal circumstances do support, a prevalence of vegetation typically adapted for life in saturated soil conditions, including swamps, marshes, bogs and similar areas.

This means that during the growing season, a wetland is an area having **sufficient water supply**, to create **soil conditions that lack oxygen** (known as anaerobic conditions), and to support **plant life adapted to a wet environment** (known as hydrophytic vegetation).

Although "wetlands" is a collective term that includes a diverse group of wet natural environments, wetlands share three basic characteristics that make them unique components of the environment:

- **The presence of water** (hydrology) at or near the surface for a portion of the year,
- **Plants that are adapted to wet conditions** (hydrophytic vegetation), and
- **Soils that result from wet conditions** (hydric soils).

These three characteristics are interrelated. Together, the presence of only one of these is usually sufficient to identify a wetland for planning purposes. **Of the three, the presence of water is the driving force that creates and maintains wetlands. The types of plants and soil characteristics may indicate the frequency and duration that water persists in an area. The types and locations of wetlands that may form on the landscape are also reflective of where the water is coming from (i.e., below ground, spring seeps, overland flow) and how long it persists, which is why landform or topography is an important factor to consider.**

a. Wetland Identification

DEP utilizes the U.S. Army Corps of Engineers 1987 Wetland Delineation Manual as its means for identifying and delineating wetlands. In addition, the U.S. Army Corps has developed regional supplements to this manual for region specific wetland identification procedures. In Pennsylvania, there are three applicable regional supplements depending on the site location: Atlantic and Gulf Coast Plain, Northcentral and Northeast Mountains, and Easter Mountain and Piedmont Regional Supplements. See:

https://www.usace.army.mil/Missions/Civil-Works/Regulatory-Program-and-Permits/reg_supp/.

In addition to reading the manuals, DEP encourages preconditioners to seek out training in wetland identification and delineation.

Identification of wetlands relies on the identification of three wetland parameters under normal circumstances: hydrology, hydric soils and wetland vegetation. **While this guide provides a basic overview of what these include, a practitioner should review and understand the wetland identification manuals.** Wetland identifications and delineations cannot always be performed at the wet times of the years. To determine if the parameters are met, indicators of these three parameters are most commonly used and explained in the regional supplements.



ACOE Wetland Delineation Regional Supplements

Hydrology indicators are used to identify if wetland hydrology is present at a site. While standing water is an obvious sign of wetland hydrology, there are many other indicators of wetland hydrology. In forested wetlands these could include shallow groundwater, sediment deposits moss trim lines, just to name a few. These hydrology indicators are clearly explained with color photographs in the Army Corps Regional Supplements to the Wetland Delineation Manual. The graphic below depicts hummocks, a type of microtopographic relief, and a feature allowing plants to adapt and survive in the saturated conditions of a wetland.



The presence of hydric soils is another factor used to in wetland identification. Hydric soils form under the oxygen depleted conditions that develop from the saturation occurring in wetlands. These soils take significant time to develop and as such often tell the “story” of the wetland hydrologic cycles. To aid in hydric soil identification, the NRCS Field Indicators of Hydric Soils in the United States is utilized by the U.S. Army Corps Delineation Manual Regional Supplements. See:

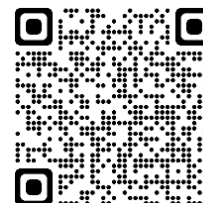

NRCS Field Indicators of Hydric Soils

<https://www.nrcs.usda.gov/wps/portal/nrcs/main/soils/use/hydric/>.

Wetland vegetation is the third factor used in wetland identification. While in forested settings the focus can be on trees, all strata of vegetation must be evaluated and accounted for in evaluating wetland vegetation. The Army Corps Regional Supplements identify specific procedures in identifying if the vegetation community sufficient to indicate a wetland is present. As part of this, each plant species is assigned a wetland indicator status. These indicator statuses are maintained by the Army Corps of Engineers as the National Wetland Plant List. See:



National Wetland
Plants List

http://wetland-plants.usace.army.mil/nwpl_static/v34/home/home.html

Once a wetland has been identified, it is important to identify the boundaries of this waters. Wetland boundaries can often fall along sharp changes in slope and topography of the land. However, the **boundary of a wetland** can be established approximately at the point at which none of these indicators are found.

Things to Look for to Identify Wetlands in Pennsylvania's Forests:

- Landscape and Other Forest Features Favorable to Wetlands:
 - (1) Hummocks.
 - (2) Favorable Landscape Positions/landforms such as but not limited to convergent slopes, toe slope terrace, backwater depressions, etc.
 - (3) Vernal Pools.
 - (4) Sphagnum moss.

- Hydrology Features:
 - (1) Water stains/water marks.
 - (2) Aquatic fauna.
 - (3) Microtopographic relief.
 - (4) Iron sheen, Iron staining, Iron deposits on the surface.
 - (5) Sparsely vegetative concave surface.
 - (6) Drainage patterns.
 - (7) Saturation or inundation.

- Soils: A Depleted Matrix Soil Profile (Hydric Soil Indicator F3). In general, this will appear as a reduced greyed matrix with redox features (usually rusty iron deposits appearing as mottles).
 - (1) A Depleted matrix soil profile below a dark surface layer (Hydric Soil Indicators A11 or A12).
 - (2) A Dark soil profile with redox features in it (usually rusty iron deposits appearing as mottles).
 - (3) Muck soils.

While depicted in black and white in the graphic below, these features in soil will generally have a grayish background, often with a “mottled” appearance, with contrasting bright orange to reddish specks, splotches or streaks.

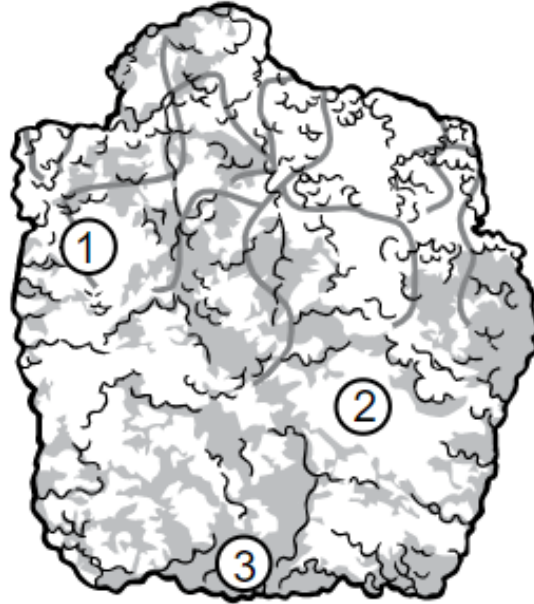

- ① (dark gray lines) - red/orange coated pore linings
- ② (white) represents the matrix color - the dominant background color could be darker grays to brownish or reddish grays
- ③ (lighter gray splotches) - Red/orange redox concentrations

- Plants:
 - (1) Plant Adaptations to the wet environment.
 - (a) Shallow roots at or near the surface. These areas often have tree throws present. Note: there are many wetlands which contain hemlocks or hemlock swamps where the hemlock trees have adapted using shallow roots to survive in the wetland.
 - (b) Fluted or buttressed trunks.
 - (c) Stooling/multiple trunks.
 - (d) Tussocks.
 - (2) Common wetland trees and shrubs in PA (see **Appendix B** for more common wetland trees and shrubs):
 - (a) Willows.
 - (b) Silver Maple.
 - (c) Sycamore.
 - (d) Black or Green Ash.
 - (e) Box Elder.
 - (f) High Bush Blueberry.
 - (g) Shrub Type Dogwoods.
 - (h) Alders.
 - (i) Buttonbush.
 - (3) Common wetland emergent plants in PA (see **Appendix B** for more common wetland emergent plants):
 - (a) Cinnamon Fern.
 - (b) Rushes.
 - (c) Jewel Weed.
 - (d) Skunk Cabbage.

- (e) Sedges.
- (f) Joe Pyeweed.
- (g) Sensitive Fern.
- (h) Ostrich Fern.

The graphic below depicts fluted and buttressed tree trunks. These are adaptations of the trees to survive in wetland hydrology conditions.



b. Appropriate Timber Harvesting Practices for Forested Wetlands

Timber production is recognized as a land use that is compatible with wetland protection provided habitat is maintained and BMPs are implemented. However, access systems, which include haul roads, skid trails and landing areas, can affect water quality and hydrology. Extra care must be taken when carrying out forestry operations in wetlands because of their vulnerability to soil compaction, accelerated erosion, reduced site productivity, habitat destruction and disturbance of their water systems. Harvesting should be done with regard to season, maintaining standing trees for habitat, soil type, soil moisture, and type of equipment used. Good planning and supervision will protect site integrity and enhance regeneration. Careful implementation of BMPs will protect important wetland functions while allowing cost-effective timber harvesting.

Wetlands are considered waters of the Commonwealth. Although structures and activities that change the hydrology of a wetland are regulated by Chapter 105, the potential for sediment pollution to wetlands must be minimized as required by Chapter 102.

Federally jurisdictional wetlands are also regulated as waters of the United States; however, normal forestry operations in wetlands such as site preparation, harvesting, and minor drainage are exempt from federal permit requirements under Section 404 of the Clean Water Act (refer to **Appendix E** of this guide) as long as the activity:

- Qualifies as “normal silviculture” (33 CFR § 323.4(a)(1)(i)).
- Is part of an “established” silviculture operation (33 CFR § 323.4(a)(1)(ii)).

- Follows at a minimum the fifteen-mandatory road BMPs (33 CFR § 323.4(a)(6)).
- Does not discharge any toxic pollutants listed under Section 307 of the Clean Water Act in dredge or fill materials into waters of the United States (33 CFR § 323.4(b)).
- Is not part of an activity whose purpose is to convert a water of the United States into a use to which it was not previously subject (33 CFR §323.4(c)).

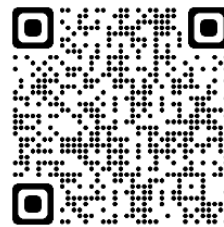

EPA Website on Section 404 of the Clean Water Act
epa.gov/cwa-404

The following recommended forest practices are consistent with the existing silvicultural exemptions contained in Section 404(t) of the Clean Water Act. In addition, timber harvesting operators should meet many of the requirements of DEP's general permits for road crossings in wetlands by following these BMPs.

i. Wetland Crossings

Wherever possible, wetland crossings must be avoided, especially if alternatives exist. If the crossing cannot be avoided, locate and orient the crossing so as to have the least amount of disturbance, usually at the narrowest practicable point of the wetland. Wetland crossings must be appropriately permitted under Chapter 105, and all conditions of the permit must be adhered to.

Temporary crossings should be constructed from materials that can be placed with a minimum of disturbance to the soil surface and completely removed when no longer needed. Some examples of stabilized crossing methods are illustrated in **Figures 1-3** below.

Figure 1. Typical Tire Mat Wetland Crossing

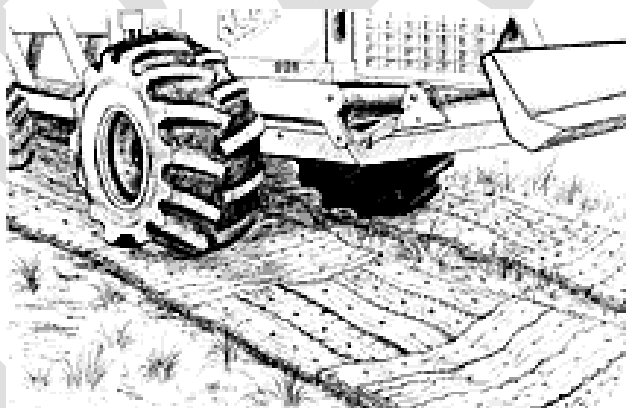

Derived from University of Minnesota FS 07013

Figure 2. Typical Expanded Metal Grating Wetland Crossing

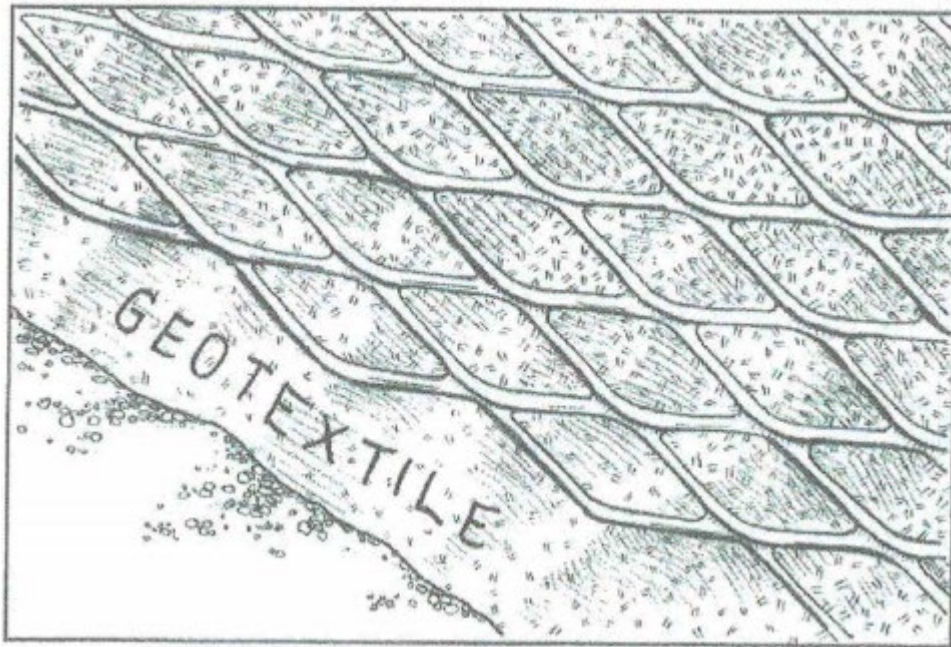

Derived from University of Minnesota FS 07011

Figure 3. Typical Wood Mat for Wetland Crossing

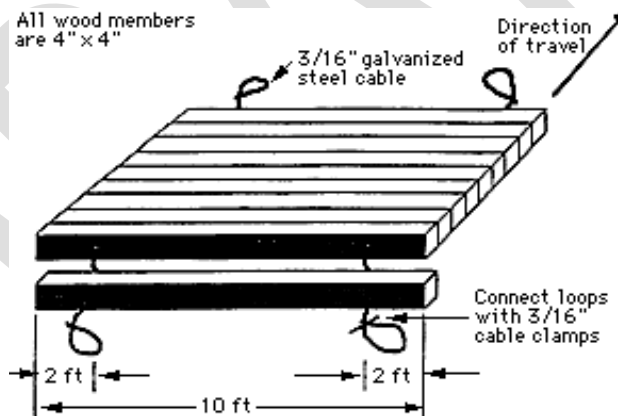

Derived from University of Minnesota FS 07009

A geotextile underlayment should be used under the wood mat.

ii. Felling

Proper precautions should be taken when logging near a wetland or stream. Overharvesting of a forested wetland can prevent regeneration and may have lasting impacts on the wetland. Excessive slash left in streams, ponds and lakes may cause negative impacts to those resources. Felling trees into water bodies can cause habitat damage and disturb breeding and spawning areas of aquatic species and amphibians. The following are only recommendations and are not requirements but are intended to provide guidelines and guidance on avoiding and minimizing impacts to wetlands.

- Avoid felling into standing water.
- Keep slash out of streams and wetlands with standing water, lakes, and ponds.
- Leave tops in the wetland if felling into standing water cannot be avoided.
- Avoid felling into temporary ponds.
- Harvesting of forested wetlands should be selective and maintain forest canopy and trees throughout the wetland post-timber harvest to sustain wetland habitat.
- Harvesting in Exceptional Value (EV) wetlands should be avoided to the greatest extent practicable.
[See 25 Pa. Code 105.17\(1\).](#)



See 25 Pa. Code 105.17(1)

iii. Skidding

Soil disturbance, which leads to accelerated erosion, can be minimized by well-designed and located skid trails or skid roads.

- Avoid and minimize equipment entry into wetlands to the greatest extent possible.
- If skidding equipment is required to enter wetlands, schedule the harvest during the drier seasons of the year or during time when the ground is frozen. Skidding should cease when surface rutting occurs.
- Skidding should be confined to a few primary trails regardless of season to minimize the area affected.
- Concentrate skidding in defined corridors and use cable skidding when possible. Minimize skid trails by maximizing winch and choker cable lengths.
- Avoid grapple skidders unless the material is gathered by a swinging head feller-buncher located outside of the wetlands.
- Use low ground pressure equipment when possible, and in wettest areas consider using tracked vehicles. Use conventional tires on skidders only when the ground is dry or frozen.
- Use brush or corduroy to minimize soil compaction and rutting when skidding in wet areas.
- Use only approved or permitted road crossings.
- Never skid through vernal pools or across stream channels.
- Avoid skidding through temporary ponds, wetlands or spring seeps to the greatest extent possible.
- Reduce skid volumes when skidding through wetland areas.

iv. Landings

Proper water control measures, location, and size of landings will limit soil erosion and compaction that can occur from concentrated heavy equipment use.

- Do not locate log landings in wetlands.
- Avoid spills of oil and other hazardous material and store operating supplies of such materials away from wetlands and waterways.

v. Haul Roads

When properly located, constructed and maintained, roads will have limited impact on water quality, hydrology, erosion, and wildlife and fish habitat. Particular care should be exercised to avoid making permanent changes in water levels and drainage patterns.

- Avoid wetlands and stream crossings through areas known to provide habitat for rare, threatened and endangered species, and avoid crossing through headwaters of public water supplies.
- Allow roads time to settle between construction and use.
- Avoid road construction during wet periods.
- Minimize road width to the size necessary to carry traffic.
- Use fabric mats or pads under fill to minimize disturbance to wetlands and facilitate removal of temporary roads.
- Construct haul road entrances to prevent mud on truck tires from getting on paved road surfaces that could wash into nearby wetlands.

vi. Vernal Pools and Spring Seeps

Vernal pools are seasonal pools that fill with water in the spring and fall. Vernal pools are a unique wetland habitat that provides for a vast amount of diversity in wetland systems and are the sole source of breeding for many amphibians. In addition, their hydrology is in a delicate balance where it is present at just the right time to promote breeding and reproduction and are gone later in the year. As such, their functions are unique and can be easily disturbed by timber harvest practices.

Spring seeps are small wetlands typically found in sloping terrains where groundwater reaches the surface and shallow, broad flows move outward, creating a saturated zone. The groundwater can flow year-round or be present seasonally. Although seeps and vernal pools only contain occasional trees, both are effectively shaded by the overlapping crowns of the adjacent forest trees.

Vernal pools and spring seeps provide quality wildlife habitat and should be protected from the impacts of timber harvesting activities. Special management practices should be applied when operating around ponds, vernal pools and seeps.

- Use filter strips around vernal pools and seeps.
- Harvesting of timber should be avoided in vernal pools or within a complex of pools and within a buffer around them.
- DEP recommends that a no-harvest buffer be applied around vernal pools to ensure canopy retention and prevent drainage of the pools. The no-harvest buffer should be no less than (2) tree crown widths (or 100 feet) around individual pools with a recommended 4 tree crown widths (or 200 feet) around pool complexes or high-quality individual sites and include the entire area of land and slope which may be impounding the pool(s).
- It is recommended that clear-cutting is avoided and selective cutting used in the areas from the recommended vernal pool buffer boundary outward to 1,000 feet to maintain ambient water quality and hydrology characteristics and to protect core amphibian habitat, which includes the upland areas immediately adjacent to vernal pools.
- Many vernal pools contain habitat for threatened and endangered species. A PNDI Search should be conducted for all wetlands which will have harvesting occur in them. Harvesting in wetlands which are habitat for threatened and endangered species should be avoided.
- Fell trees away from vernal pools or seeps.
- Leave tops in the wetland if felling into standing water cannot be avoided.
- Do not skid through vernal pools, seeps or wetlands.
- Avoid making ruts near or within a vernal pool. Harvesting under frozen or snowy conditions is advisable to minimize rutting and disturbance of leaf litter.
- Locate haul roads downstream from the head of a seep, and avoid road building directly uphill from seeps.

- Concentrate skidding on defined corridors and use cable skidders when possible. Minimize skid trails by maximizing cable lengths to reduce erosion and sedimentation.

C. Site Layout

Use of BMPs not only protects streams and wetlands, but also benefits loggers and landowners. Loggers know that the layout of a timber harvest can have a tremendous impact on an operation's productivity. A poorly laid out harvest can result in inefficiencies, bottlenecks, and lost potential revenues. However, careful planning that results in proper site layout and the use of appropriate BMPs not only generates a more efficient operation, it also helps protect the environment:

- Limits wear and tear on machinery and equipment
 - Cleaner wood; less chain sharpening and easier product preparation
 - Less down-time because of poorly designed road and impassable skid trails
- More efficient utilization of equipment and manpower
 - Less idling of the skidder
 - Faster turn-times
 - Fewer skid trails needed
 - Less time constructing stream crossings
 - Smaller more efficient landings
 - Less time for post-harvest cleanup
- Minimizes impact of timber harvesting on the environment
 - Reduces soil disturbance and compaction
 - Reduces erosion and sedimentation
 - Maintains water quality
 - Protects fish and wildlife habitat
- Maintains forest productivity
 - Aids forest regeneration
 - Protects future growing stock
 - Protects biological diversity
- Adherence to higher environmental standards
 - Competitive advantage from higher quality operations
 - Improves landowner relationships
 - Better acceptance of the industry by the general public
 - More interest from potential clients

The principal areas of earth disturbance associated with a timber harvest that need careful consideration are haul roads, skid trails and landing areas. Managing erosion on logging road systems is a water control problem. The very first and most important step is to locate these features in areas that will maximize efficiency and cause the least potential for accelerated erosion. The next step is to build a functional drainage system of culverts, dips, bridges, turnouts, and out-sloping or in-sloping roads to carry water away. After that, the road must be kept reasonably free of ruts, curbs and logging debris that may prevent water from moving freely into drainage structures. The basic principal is to get the water off the road as soon as possible.

Figure 4 is an example of a typical timber harvest site plan and **Figure 5** is an alternative timber harvest site plan.

Figure 4. Typical Timber Harvest Site Plan

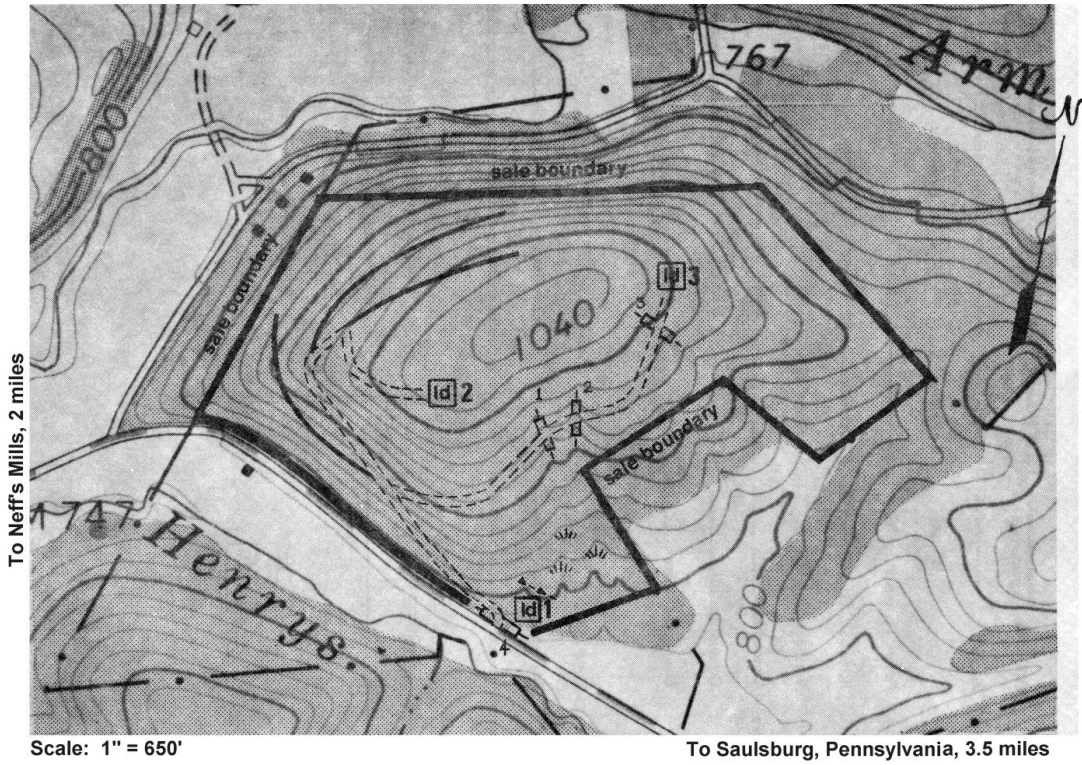
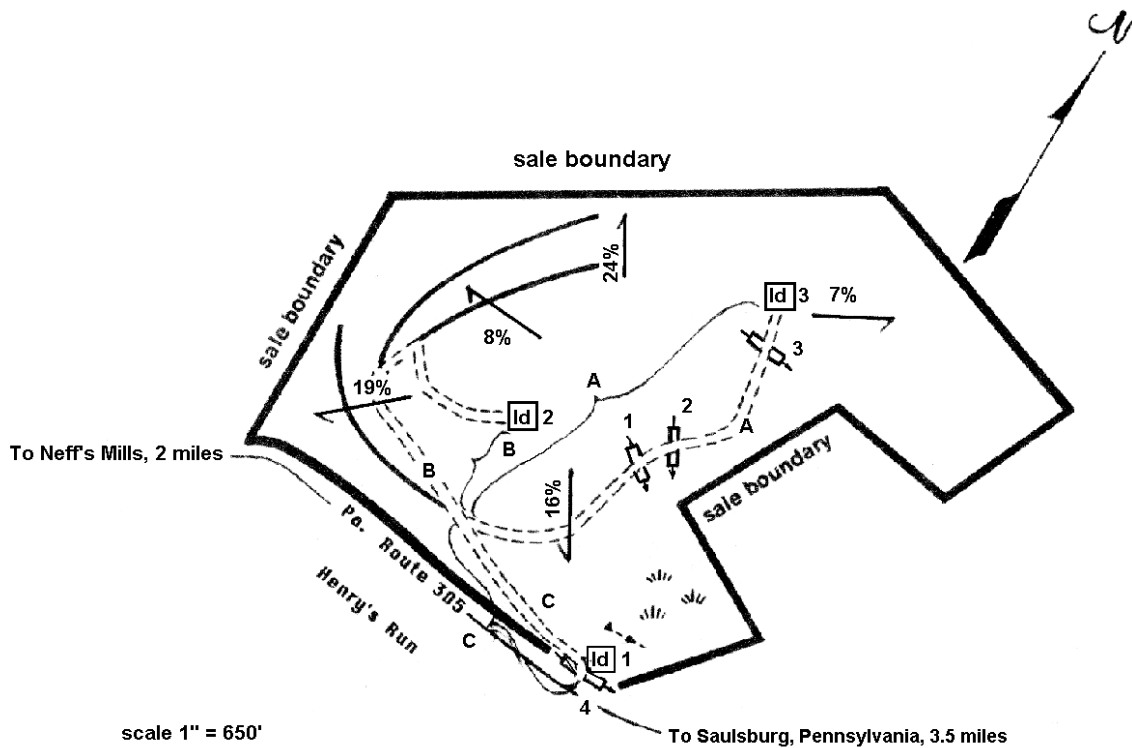

Figure 5. Alternative Timber Harvest Site Plan



1. Haul Roads

Haul roads for a timber harvest project typically run from the landings to the entrance(s). Every haul road system should be planned and developed as if it will be a permanent road. Many haul roads initially considered to be temporary, are often used again and again. Therefore, the entire haul road system should be designed before any haul road construction begins. This process may seem to take more time, but the haul road system will be more efficient, less costly and easier to maintain.

The following points should be considered when laying out a road system:

- **Construct only as much road as necessary.** Minimize clearing. Keep road width to the minimum necessary for safe and efficient operation.
- **Terminal points** - Locate the start and end of the road system using the best access that is safe and visible from public roads. Locate landings away from streams and wet areas. Install rock construction entrances (Section IV.B.11) at all exit points onto a public roadway. Install an entry gate or barricade to keep potentially damaging and unwanted traffic off the haul road. **NOTE: A highway occupancy permit may be required.**
- **Grades** - Haul roads with a maximum slope of 10% and a minimum of 2% are usually the easiest to maintain. Where absolutely necessary, grades of 15 to 20% can be used for short distances. Follow the contour as much as possible.
- **Topography** - Roads on moderate side hills are easiest to build and drain. Avoid steep slopes wherever possible.
- **Drainage** - Construct roads to drain at all times, such as using crowned or insloped surfaces. Install ditch relief culverts (Section IV.B.1.) at specified intervals, as shown in Table 2 or 3. Provide outlet protection at all culvert outfalls. Turnouts, as shown in Figure 3.3, may be used on low-side ditches to direct flow into filter strips.
- **Grading** - Minimize cut and fill work, and keep slopes at stable angles. Remove trees from tops of cuts when the root system is undercut, and seed and mulch cut and fill slopes promptly (Section IV.B.12.). Do not place fill into open sinkholes, waterways, wetlands, floodways, or other sensitive areas.
- **Obstacles** - Design the road system to go around springs, seeps, wetlands, poor drainage areas, ledges and rocky areas wherever possible.
- **Soils** - Be aware of soil texture, drainage class and slope position as outlined in Appendix E of DEP's E&S Manual (DEP Document #363-2134-008, March 2012). Some soils are poorly drained or seasonally wet and are difficult to log. Others are unstable when support is removed to make a road cut or when used as fill. The NRCS soils website should be consulted to identify soil limitations. Minimize the traffic areas. Running equipment over soil compacts it and damages its ability to infiltrate runoff.
- **Distances from streams** – Filter strips should be maintained along stream corridors to provide sediment filtration and maintain stream temperatures. Wherever sufficient filter strips are not possible between roadways and receiving waters, install BMPs, such as silt fence (Section IV.B.7) as the roadway progresses. See Section IV.B.6 for minimum filter strip widths.
- **Stream & Stream Crossings** - See Section III.B.2. for stream and stream crossing considerations, minimize the number of stream crossings. Cross at a 90-degree angle and approach the stream from as gentle a slope as possible. **NOTE: A Chapter 105 permit and SLLA may be required.**
- **Old roads** - It is often possible to use existing roads and thereby lessen soil disturbance. However, to avoid problems, carefully evaluate the road's suitability for upgrading.
- **Size and duration of the sale** and the anticipated season of harvest.
- **Floodways** - See Section III.B.2. for stream and floodway considerations. Roadway construction within floodways — typically 50 feet from top of streambank — and wetlands require Water Obstruction and Encroachment permits.

- **Floodplains**- Identify their location and the potential for impact. Avoid floodplains and wetlands if possible.
- **Wetlands & Wetland Crossings** - See Section III.B.3. for wetland and wetland crossing considerations.
- **Water control structures** - Carefully plan the use of broad-based dips, waterbars, culverts, and ditches to maintain existing flow patterns and minimize the amount of runoff being conveyed by roadways and roadside ditches.

2. Skid Roads and Skid Trails

The primary difference between a skid road and a skid trail is the degree of preparation for use. Main skid roads should be flagged, cleared and graded. Skid trails, which are used for transporting logs from stump to main skid road, are usually not graded and need only minimal clearing. In developing a skid road and trail system, pay special attention to proper drainage and soil stabilization. The following items should be considered:

- **Grades** - Keep grades as low as the topography will permit. Do not go straight up the slope; proceed across the slope as much as possible. Grades of 20% or more should be avoided. Where unavoidable, they should be kept to short distances and make use of waterbars.
- **Use Waterbars** wherever it is not possible to avoid going straight up or down slopes.
- **Avoid, Rocky Slopes and Steep Grades.**
- Skid trails and skid roads should be located at least 50 feet from stream channels wherever possible.
- **Stream & Stream Crossings** – See Section III.B.2 for stream and stream crossing considerations. Use temporary bridges or culverts and obtain all appropriate permits/authorizations.
- **Wetlands & Wetland Crossings** – See Section III.B.3 for wetland and wetland crossing considerations.

3. Log Landings

Log landings are used to store and process logs and other products prior to loading and transportation. The number and size of landings should be kept to the minimum necessary to operate safely and efficiently. Few erosion problems are associated with a properly located landing. Problems will occur, however, when water control is not considered in selecting a location. Only sites that will hold up under the anticipated use by heavy equipment should be chosen. Avoid sensitive areas such as riparian management zones, waterways, wetlands, caves, spring seeps, and open sinkholes. Allow adequate undisturbed filter strips between the landing and streams or sensitive areas (Section IV.B.6).



E&S Pollution Control Manual

Disturb only the area needed for safe operations. If the topography warrants, use a diversion channel, as described in Chapter 6 of DEP's E&S Manual, above the landing to keep upslope runoff from entering the landing area. The diversion channel should have a suitable protective liner and outlet to an existing waterway wherever possible. If no waterway exists, the discharge should be directed to a stable area. If leveling is necessary, cut and fill should not alter the natural drainage pattern of the area.

Heavy equipment quickly compacts soils on landings, preventing water from infiltrating. Consider the use of fabric mats and pads at landing sites to minimize soil erosion and compaction. The landing should be sloped so as to direct runoff to a sediment removal BMP such as a wood chip berm, silt fence, straw bales, etc.

Skid roads, skid trails, and haul roads approaching the landing from above should have a waterbar, broad-based dip, or other means of diverting flow into a stable area before it reaches the landing.

Refer to Section III.B.3 of this guide for additional log landing considerations related to wetlands.

4. Pollution from Geological Formations

Coal and black shale typically contain pyrite, a mineral composed of iron and sulfur. When pyrite is exposed to the atmosphere, it weathers, producing sulfuric acid and iron. The sulfuric acid can dissolve additional undesirable elements from the rocks, such as aluminum and manganese. If these acid-producing rocks (APR) are disturbed during timber harvesting earth disturbances and are not properly handled, streams and groundwater can become polluted.

The best way to avoid pollution is to avoid disturbing the materials that cause pollution and to ensure that these materials are not being brought to the project site for fill or aggregate. If it is known that APRs, such as coal, will be encountered, any excavation should either be moved to an area that does not contain these rocks or the rocks must be dealt with in a way that reduces the risk of pollution. However, typically the upper 25 to 35 feet of bedrock does not contain pyrite because pyrite is not stable under atmospheric conditions and will weather away. If excavations are shallower than 30 feet, as is the case on most timber harvesting operations, the risk of acid drainage is generally minimal. This is particularly true if a site is located south of the glacial margin. Within the glaciated regions of Pennsylvania weathered bedrock may have been removed by glaciers and pyrite may exist closer to the surface. Unconsolidated sediments, such as glacial till, sand, and gravel, are not acid-producing and can be dug into without risk of acidic drainage. Refer to DEP Fact Sheet, "How to Avoid and Handle Acid-Producing Rock Formations Encountered During Well Site Development" (DEP Document ID# 5600-FS-DEP4284) for additional information.

E&S Plans for timber harvesting operations need to identify any known geologic formations or soil conditions on the site that may have the potential to cause pollution during earth disturbance activities and include BMPs, when necessary, to avoid or minimize potential pollution and its impacts from such formations (e.g., proper handling, isolation, disposal, etc.).

Bedrock or soil conditions which could result in significant slope failures resulting in mass soil movement into surface waters, property damage, or a public safety hazard should also be identified. The E&S Plan narrative should briefly state the methods incorporated into the plan which address such hazards, when necessary. Plan maps should clearly mark the locations where potential for slope failures exist, and appropriate construction details and typically should be provided on the plan drawings, when necessary.

5. Thermal Impacts to Surface Waters

Temperature is a significant water quality parameter. It strongly influences levels of oxygen and solids dissolved in streams. Temperature changes can induce algal blooms with subsequent changes in taste, odor, and color of a waterbody. Warm water is also conducive to the growth and development of many species of aquatic bacterial. In short, water temperature is a major determinant of the suitability of water for many uses and is regulated under Pennsylvania's Clean Streams Law.

Removal of canopy cover might induce minor thermal impacts which can be mitigated by re-vegetation or reforestation of the area and maintaining or creating filter strips along surface waters and within wetlands. DEP's regulations in Chapter 102 require timber harvesting E&S Plans to address any potential thermal impacts to waters of the Commonwealth, and identify any treatment and/or mitigation plans, dependent on the type of impact.

IV. SITE MANAGEMENT

Haul roads, skid trails, and landing areas have the potential to affect water quality and hydrology. Extra care must be taken when carrying out these timber harvesting operations by implementing appropriate BMPs for the site before, during, and after the activity. These BMPs should be predetermined and clearly outlined in the timber harvesting E&S Plan for the site ahead of time. However, plans should also be adaptable and reflect any alterations resulting from unanticipated circumstances or changing conditions encountered after the operation begins.

As mentioned in Section I of this guide, it is important to remember that for every situation described, there may be more than one correct method to minimize and prevent sediment pollution.

A. BMP Responsibility

DEP regulations require that BMPs be implemented and maintained “before, during, and after earth disturbance activities” (25 Pa. Code §102.1 and § 102.4(b)(1)).

The landowner and the person responsible for the earth disturbance activity (e.g., timber harvesting operator) are responsible for complying with all regulations. E&S Plans must be prepared by a person trained and experienced in E&S control methods and techniques applicable to the size and scope of the project being designed (25 Pa. Code § 102.4(b)(3)). Therefore, landowners and operators are encouraged to seek out professional help when needed. Typically, a forester and in many cases a logger may have the training and expertise needed to develop a proper E&S Plan.

Implementation of the E&S Plan is usually the responsibility of the logger during the timber harvesting activity. The forester normally provides oversight of the operation by performing regular inspections and works with the logger to correct any existing or potential E&S issues found on the site. The forester or logger will also update the E&S Plan when any unanticipated circumstances or situations require a deviation from the original plan. When the timber harvesting activity is completed, responsibility for maintaining the BMPs on the site typically reverts back to the landowner. It is a good practice to request a final site inspection from the conservation district before this transfer of responsibility occurs to ensure that all regulatory and environmental obligations have been met.

It is a good idea for the E&S Plan to clearly identify the role and responsibilities of all entities involved in the sale. When using the Erosion and Sediment Control Plan Template for a Timber Harvesting Operation (DEP Document ID# 3800-FM-BCW0539), it is advisable to list the logger in Section 1.D as the primary person responsible for construction and maintenance of erosion and sediment control BMPs, and to list the landowner in Section 12 as another party assigned and include an explanation that responsibility will transfer to the landowner after the timber harvesting activity has been completed and the site has been properly retired.



E&S Control Plan Template for
a Timber Harvest Operation

B. Recommended BMPs

The following standard BMP drawings and recommended spacings have been provided to fulfill the requirements of a timber harvesting E&S Plan and satisfy Chapter 102 regulations. The timber harvest E&S Plan should identify which BMPs will be used and identify their approximate location. If alternative BMPs are used the E&S Plan must include drawings showing the details, specifications, spacings, and other necessary information to demonstrate compliance with 25 Pa. Code § 102.11(b). The standards and construction details referenced are from DEP’s E&S Manual (DEP Document ID# 363-2134-008, March 2012), which contains additional information and

details. Additional approved BMPs and specifications can be found at DEP's website, Keyword Search: E&S Resources.

Timber harvesting projects that require a Chapter 102 permit and occur within a special protection watershed or discharge to an EV wetland will be required to implement nondischarge alternatives and antidegradation best available combination of technologies (ABACT) BMPs in accordance with 25 Pa. Code §§ 102.4(b)(6) and 102.8(h). Refer to Chapter 17 of the E&S Manual or Water Quality Antidegradation Implementation Guidance (DEP Document ID# 391-0300-002, November 2003) for more information.



E&S Pollution Control Manual

1. Ditch Relief Culvert (Cross Drains)

Design Standards

- Minimum diameter for any culvert is 12"; otherwise culvert shall be sized for anticipated peak flow. Place culvert so bottom is at same level as bottom of ditch or adjoining slope. Culverts shall be placed with a slope of 2 to 4%. Lower end shall be at least 2" below upper end and at ground level.
- Extend culvert 12" beyond base of road fill on both sides. Firmly pack fill around culvert, especially the bottom half.
- Provide suitable outlet protection and, where appropriate, inlet protection.
- NOTE: This detail may be used for ditch relief culverts and for crossings of roadside ditches. It is not appropriate for stream crossings.
- For steep slope (>2H:1V) outfalls, a minimum 20-foot long R-5 apron is recommended for temporary access roads where the recommended culvert spacing is used. For permanent access roads, a minimum R-6 rock size is recommended.

Maintenance

- Inspect culvert(s) weekly: remove any flow obstructions and make necessary repairs immediately.

Table 2. Ditch Relief Culvert Spacing for Temporary Access Roads

Road Grade (% Slope)	Recommended Spacing (ft)
2	300
3	235
4	200
5	180
6	165
7	155
8	150
9	145
10	140
12	135

Table 3. Ditch Relief Culvert Spacing for Permanent Access Roads

Road Grade (% Slope)	Recommended Spacing (ft)
2	500
4	400
6	350
8	300
10	250
12	200
14	150

Figure 6. Standard Construction Detail for Ditch Relief Culverts

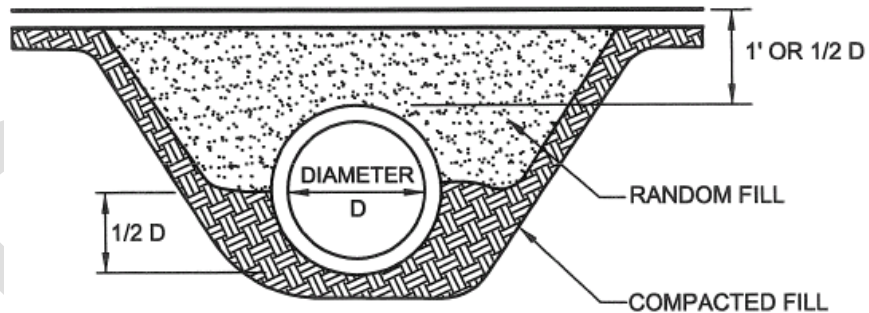
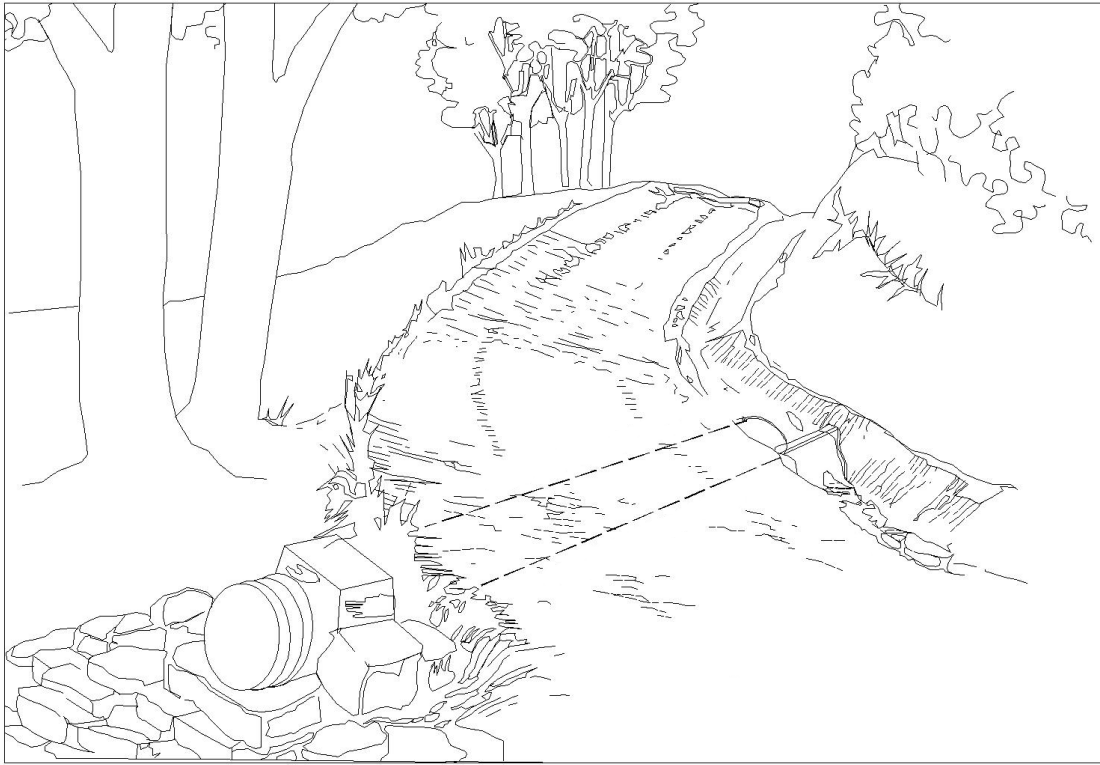

2. Waterbars

Design Standards

- Waterbars are typically used to control stormwater runoff on retired access roads and skid trails. They are not recommended for active access roads or skid trails due to the difficulty of moving equipment over them as well as the need for continual maintenance due to damage from traffic.
- Where waterbars are not practical on active access roads or skid trails, other BMPs such as Water Deflectors (Section IV.B.4) or Broad-based Dips (Section IV.B.5) can be used to control runoff.
- Waterbars shall be placed at a slight angle to allow drainage and discharge to a stable area.

Maintenance

- Waterbars shall be inspected weekly (daily on active roads) and after each runoff event. Damaged or eroded waterbars shall be restored to original dimensions within 24 hours of inspection.
- Maintenance of waterbars shall be provided until roadway, skid road, or right-of-way has achieved permanent stabilization.
- Waterbars on retired roadways, skid roads, and right-of-ways shall be left in place after permanent stabilization has been achieved.
- Waterbars that need to be removed during operations should be replaced before leaving the site at the end of the day.

Table 4. Waterbar Spacing

Road Grade (% Slope)	Recommended Spacing (ft)
0 – 5	250
5 – 15	150
15 – 30	100
30 & above	50

Figure 7. Standard Construction Detail for Waterbars

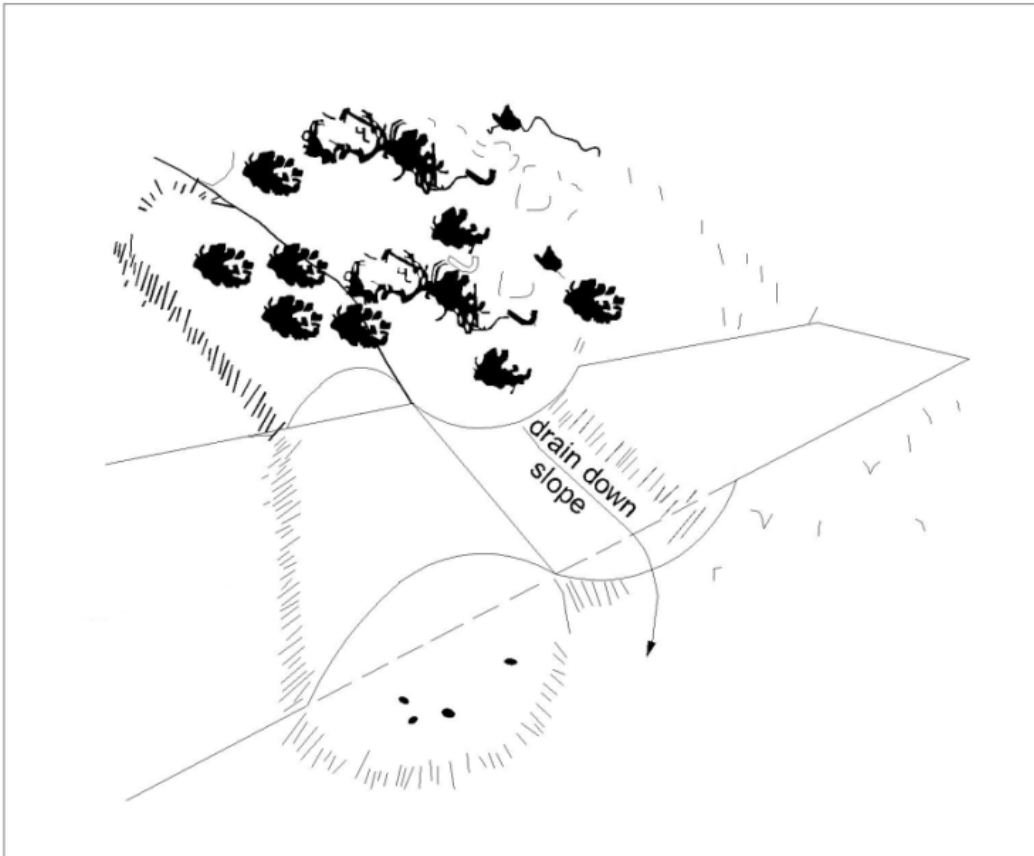

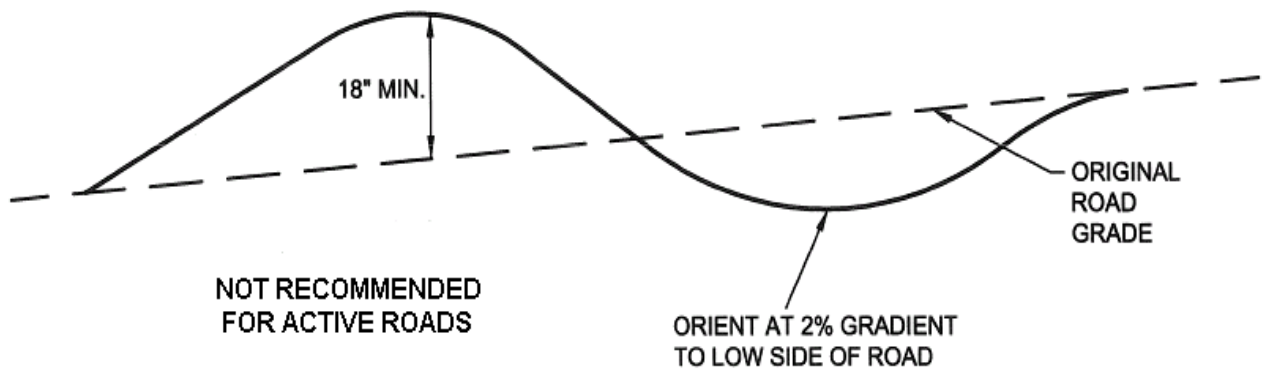

3. Turnouts

Design Standards

- Turnouts should be located so as to take advantage of natural drainage courses or filter strips whenever possible.
- An excavated sump at the end of the turnout can be effectively used to pond and settle out sediment prior to discharging to a vegetated buffer.
- Where a suitable filter strip is not available, a compost filter sock, rock filter or other sediment removal BMP should be installed at the outlet of the turnout.

Figure 8. Standard Construction Detail for Turnouts

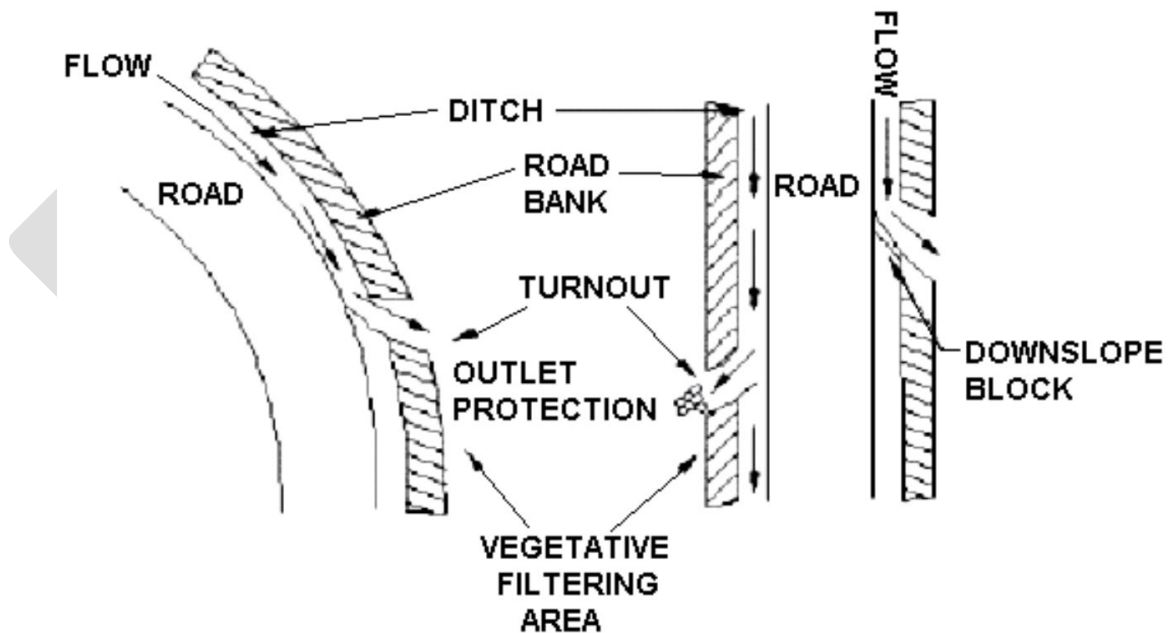

4. Water Deflector

Design Standards

- Maximum spacing of deflectors shall be as shown in **Table 5**.

Maintenance

- Deflector shall be inspected weekly and after each runoff event.
- Accumulated sediment shall be removed from the deflector within 24 hours of inspection.
- Belt shall be replaced when worn and no longer effective.

Table 5. Water Deflector Spacing

Road Grade (% Slope)	Recommended Spacing (ft)
< 2	300
3	235
4	200
5	180
6	165
7	155
8	150
9	145
10	140

Figure 9. Standard Construction Detail for Water Deflectors

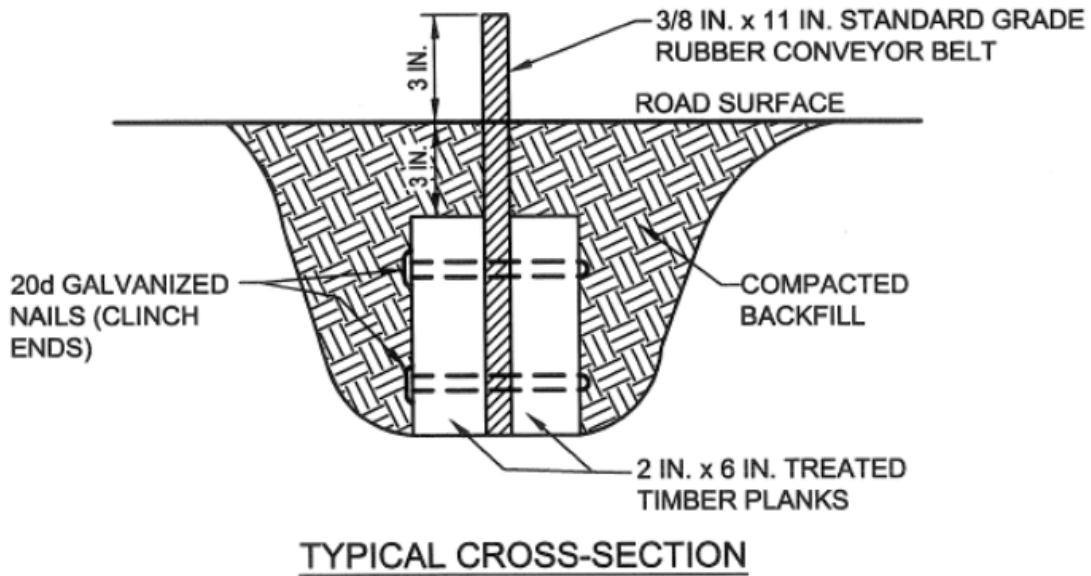

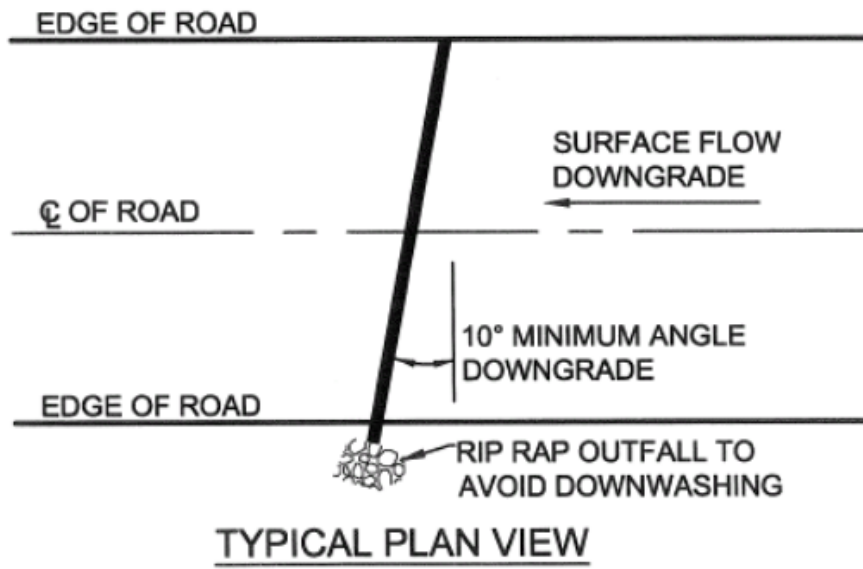

5. Broad-based Dips

Design Standards

- Broad-based dips shall be constructed to the dimensions shown and at the locations shown on the sketch map (refer to Section III.C).
- Dips shall be oriented so as to discharge to the low side of the roadway.
- Maximum spacing of broad-based dips shall be as shown in **Table 6**.

Maintenance

- Dips shall be inspected daily. Damaged or non-functioning dips shall be repaired by the end of the workday.

Table 6. Broad-based Dip Spacing

Road Grade (% Slope)	Recommended Spacing (ft)
< 2	300
3	250
4	200
5	180
6	170
7	160
8	150
9	145
10	140

Figure 10. Standard Construction Detail for Broad-based Dips

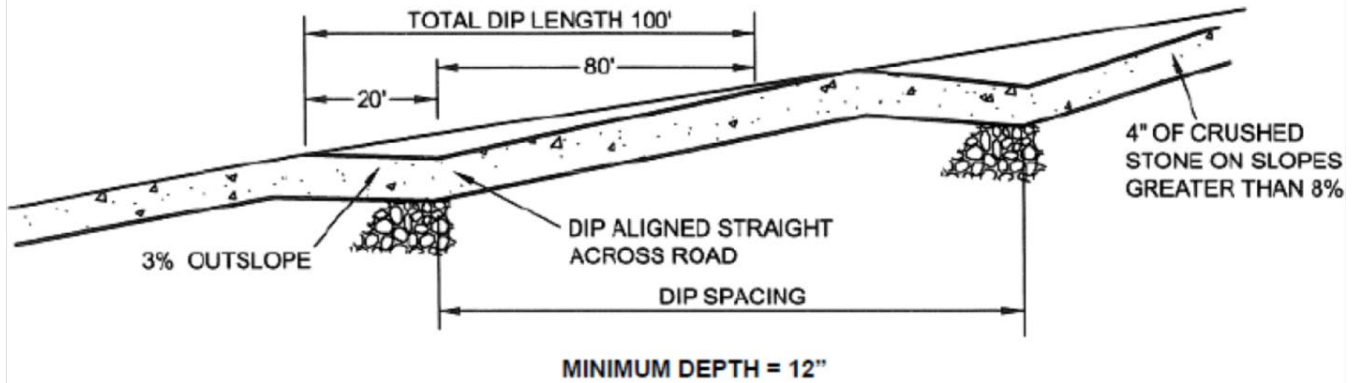

6. Filter Strip

Design Standards

- A filter strip is a strip or area of vegetation used for removing sediment, organic matter, and other pollutants from runoff and wastewater.
- To be effective, runoff should be in the form of sheet flow and the vegetative cover should be established prior to the earth disturbance activity.
- The suitability of natural filter strips should be documented by photo(s) as part of the plan.
- Meadow vegetation should be an existing, well-established, perennial grass.
- Forest filter strips consist of vegetation that is predominantly native trees, shrubs and forbs along surface waters that is maintained in a natural state or sustainably managed to protect and enhance water quality, stabilize stream channels and banks, and separate land use activities from surface waters. Trees can be harvested from forest filter strips, but should be winched or otherwise removed in a way that avoids soil disturbance within these areas. Log landings, haul roads and skid trails should be located outside of the filter strip except where stream crossing is necessary.

Maintenance

- If at any time, the width of the filter strip has been reduced by sediment deposition to half its original width, suitable replacement BMPs should be installed. The plan should specify what BMPs will be installed should this occur.

Table 7. Filter Strip Widths

Land Slope of Strip (%)	Recommended Width (ft)	
	Meadow	Forest*
≤ 10	50	75
20	65	100
30	85	125
40	105	160
50	125	190
60	145	220
70	165	250

* Consideration should be given to placing a sediment barrier (e.g., wood chip berm, silt fence, straw bales, etc.) immediately below the disturbed area due to minimal sediment removal on typical forest floors.

Figure 11. Standard Construction Detail for Filter Strips

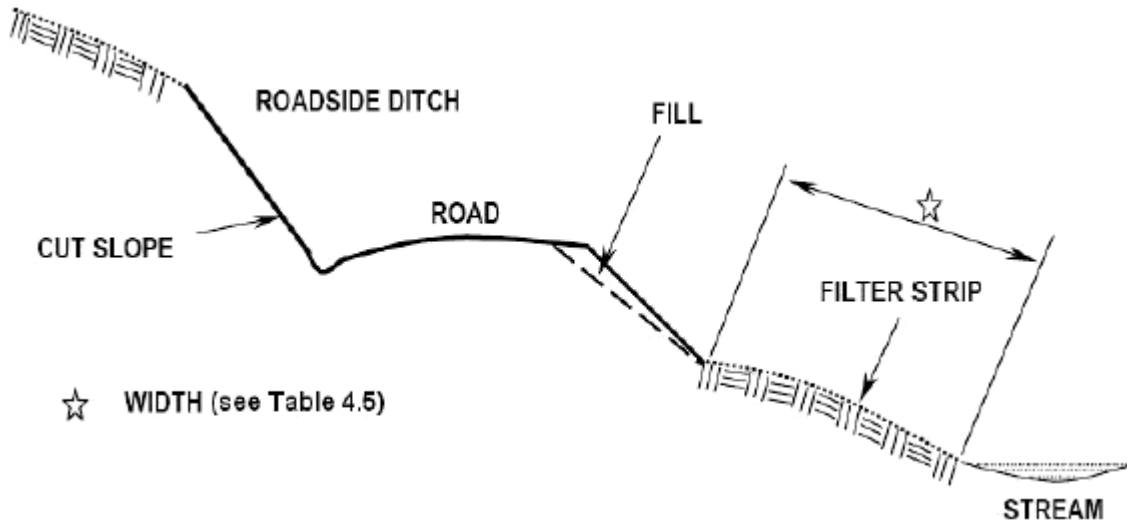

7. Silt Fence (Filter Fabric Fence)

Design Standards

- Fabric shall have the minimum properties as shown in Table 4.3 of DEP's E&S Manual.
- The maximum slope length above any silt fence shall not exceed that shown in Table 4.4 of DEP's E&S Manual.
- Fabric width shall be 30" minimum. Stakes shall be hardwood or equivalent steel (U or T) stakes.
- Silt fence shall be placed at level existing grade. Both ends of the fence shall be extended at least 8 feet up slope at 45 degrees to the main fence alignment (see Figure 12).
- Fences should not be installed in streams, ditches or other areas of concentrated flow.



E&S Pollution Control Manual

Maintenance

- Sediment shall be removed when accumulations reach half the aboveground height of the fence.
- Any section of silt fence which has been undermined or topped shall be immediately replaced with a rock filter outlet.
- Fence shall be removed and properly disposed of when tributary area is permanently stabilized.

Figure 12. Standard Construction Detail for Silt Fence

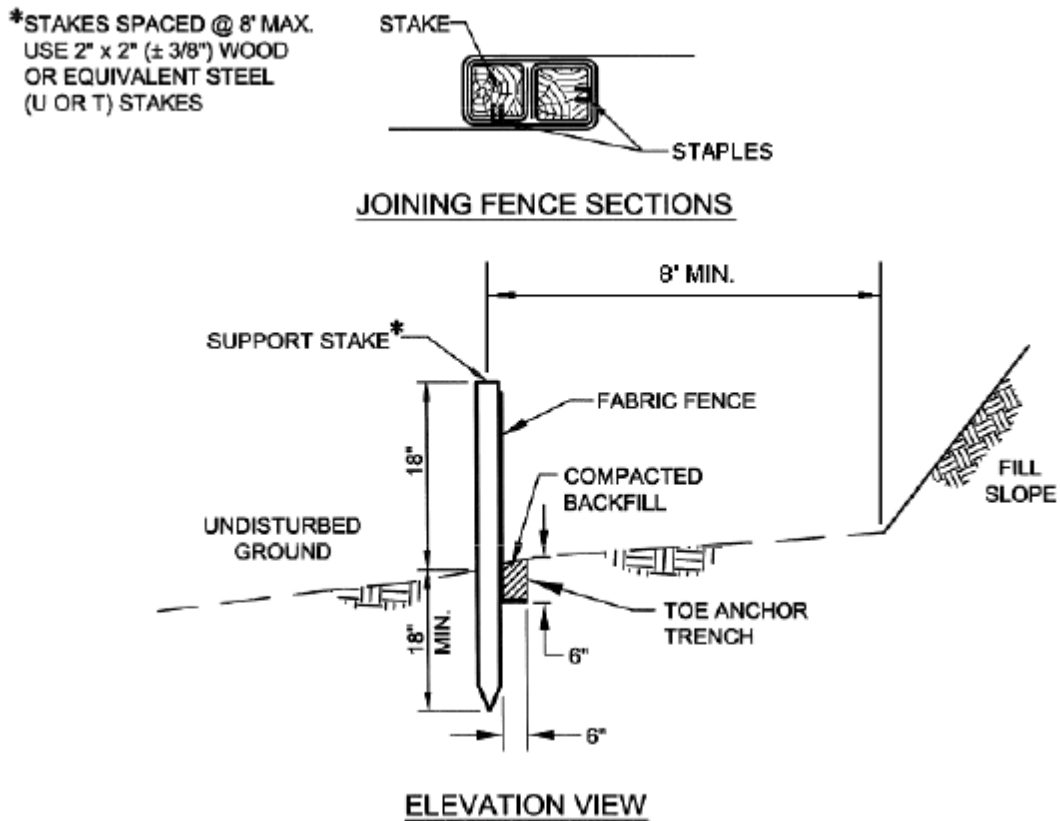

8. Compost Filter Sock

Design Standards

- Sock fabric shall meet standards of Table 4.1, and compost shall meet the standards of Table 4.2 (as revised) in DEP's E&S Manual.
- Compost filter sock shall be placed at existing level grade. Both ends of the sock shall be extended at least 8 feet up slope at 45 degrees to the main sock alignment (Figure 13). Maximum slope length above any sock shall not exceed that shown on Figure 4.2 in DEP's E&S Manual. Stakes may be installed immediately downslope of the sock if so specified by the manufacturer.



E&S Pollution Control Manual

Maintenance

- Traffic shall not be permitted to cross filter socks.
- Accumulated sediment shall be removed when it reaches half the aboveground height of the sock and disposed in the manner described elsewhere in the plan.
- Socks shall be inspected weekly and after each runoff event. Damaged socks shall be repaired according to manufacturer's specifications or replaced within 24 hours of inspection.
- Biodegradable filter socks shall be replaced after 6 months; photodegradable socks after 1 year. Polypropylene socks shall be replaced according to manufacturer's recommendations.

- Upon stabilization of the area tributary to the sock, stakes shall be removed. The sock may be left in place and vegetated or removed. In the latter case, the mesh shall be cut open and the mulch spread as a soil supplement.

Figure 13. Standard Construction Detail for Compost Filter Sock

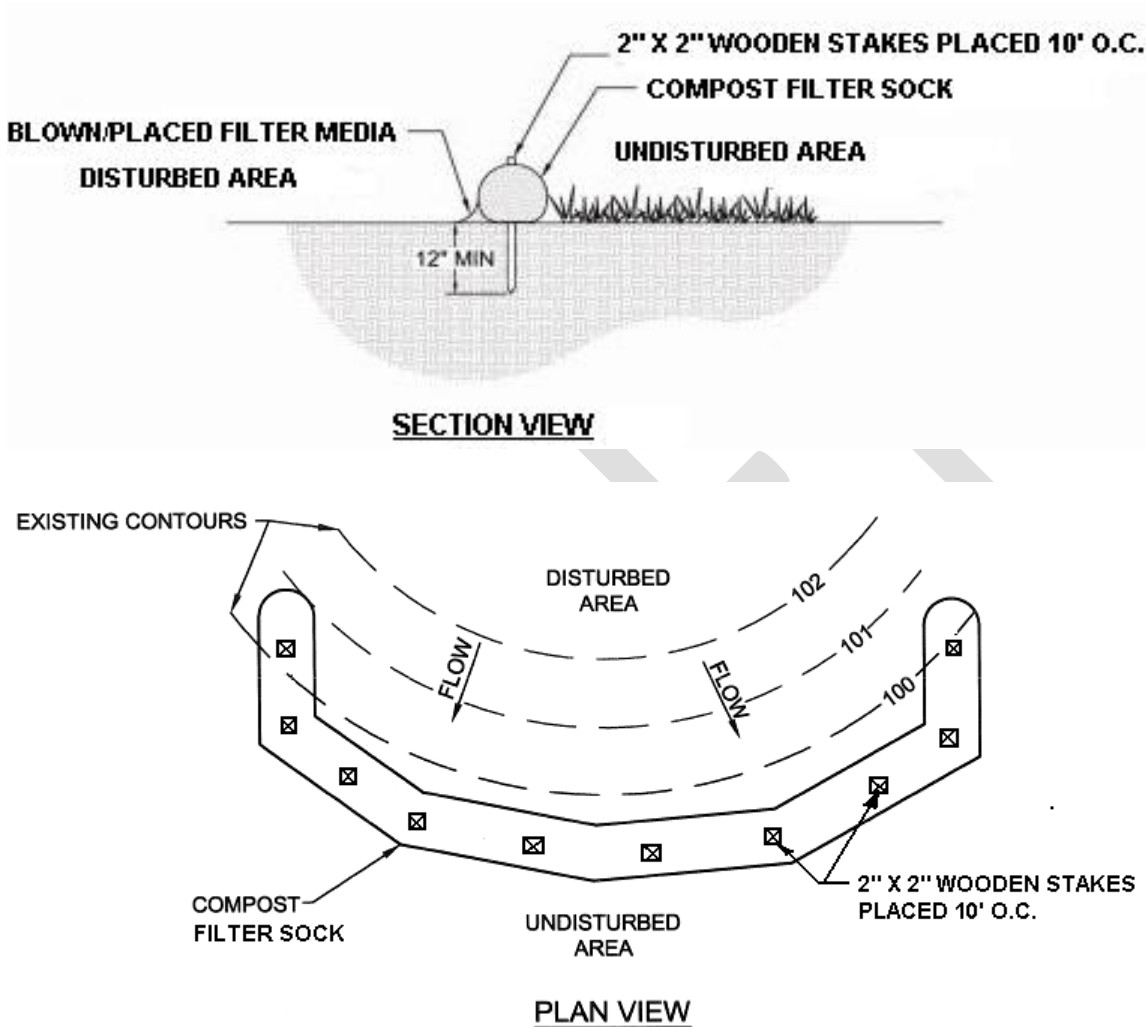

9. Straw Bale Barrier

Design Standard

- The maximum slope length above any straw bale barrier shall not exceed that shown in Table 4.5 of DEP's E&S Manual.
- Straw bale barriers shall not be used for projects extending more than 3 months.
- Straw bale barriers shall be placed at existing level grade with ends tightly abutting the adjacent bales. First stake of each bale shall be angled toward adjacent bale to draw bales together. Stakes shall be driven flush with the top of the bale (see Figure 4.4 in DEP's E&S Manual). Both ends of the barrier shall be extended at least 8 feet up slope at 45 degrees to the main barrier alignment (see Figure 4.1 in DEP's E&S Manual).



E&S Pollution Control Manual

- Compacted backfill shall extend approximately 4 inches above ground level.
- They should not be installed in streams, ditches or other areas of concentrated flow.

Maintenance

- Sediment shall be removed when accumulations reach 1/3 the aboveground height of the barrier. Damaged or deteriorated bales shall be replaced immediately upon inspection.
- Any section of straw bale barrier which has been undermined or topped shall be immediately replaced with a rock filter outlet.
- Bales shall be removed when the tributary area has been permanently stabilized.

Figure 14. Standard Construction Detail for Straw Bale Barriers

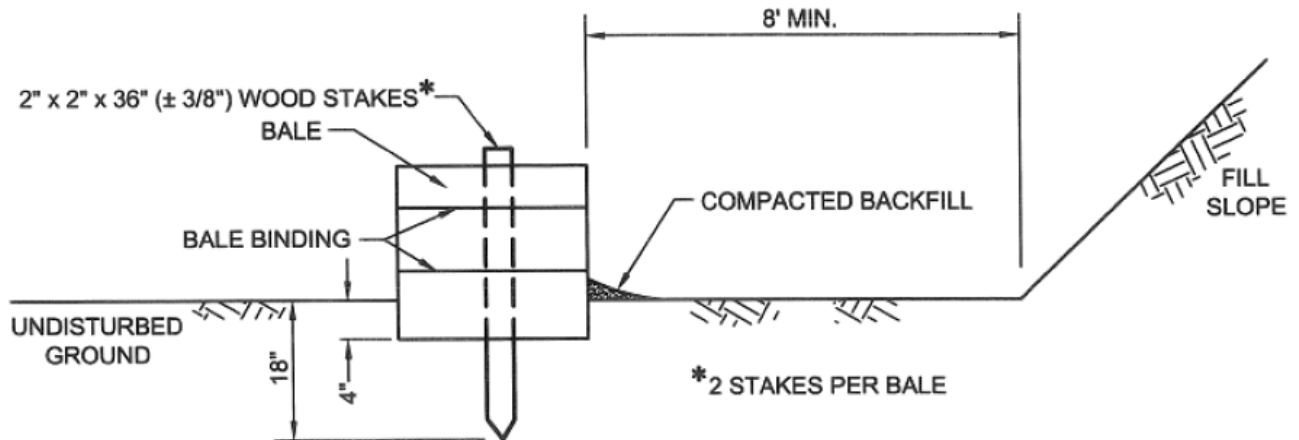

10. Wood Chip Filter Berm

Design Standards

- The maximum slope length above any wood chip filter berm shall not exceed that shown in Table 4.5 of DEP's E&S Manual.
- Prior to placement of the berm, obstructions such as tree limbs, large rocks, etc. shall be removed.
- Wood chip filter berm shall be placed at existing level grade. Both ends of the berm shall be extended at least 8 feet up slope at 45 degrees to the main berm alignment (Figure 4.1 in DEP's E&S Manual). Wood chip berms shall not be located in areas of concentrated flow or used to construct sediment traps or other impoundments.



E&S Pollution Control Manual

Maintenance

- Berms shall be inspected weekly and after each runoff event. Sediment shall be removed when accumulations reach half the height of the berm. Damaged or deteriorated portions of the berm shall be replaced immediately upon inspection.
- Berms may be leveled when the tributary area has been permanently stabilized or left in place.

Figure 15. Standard Construction Detail for Wood Chip Filter Berm

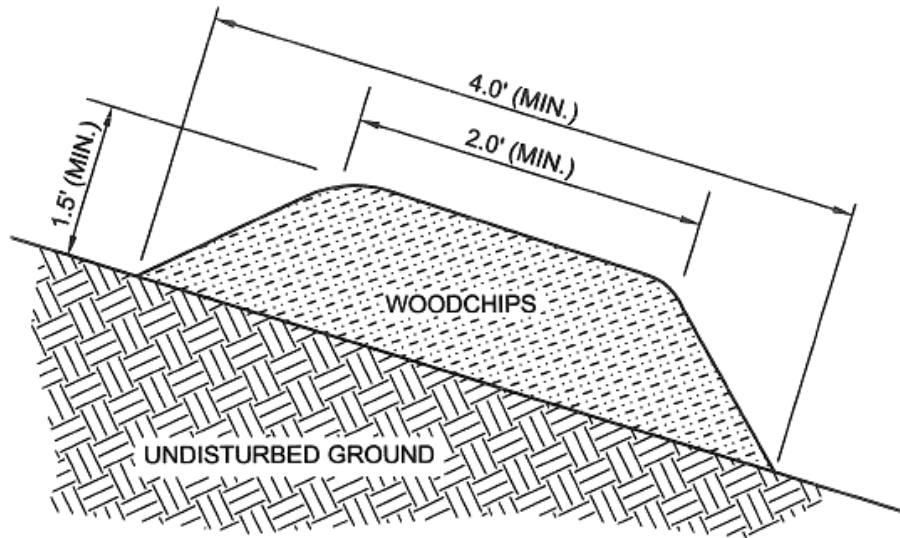

11. Rock Construction Entrance

Design Standards

- A rock construction entrance should be installed wherever it is anticipated that construction traffic will exit the project site onto any roadway, public or private.
- A geotextile underlayment should be placed over the existing ground prior to placing the stone to prevent stone from being driven into the ground.
- Remove topsoil prior to installation of rock construction entrance. Extend rock over full width of entrance.
- Runoff shall be diverted from roadway to a suitable sediment removal BMP prior to entering rock construction entrance.
- Mountable berm shall be installed wherever optional culvert pipe is used and proper pipe cover as specified by manufacturer is not otherwise provided. Pipe shall be sized appropriately for size of ditch being crossed.

Maintenance

- Rock construction entrance thickness shall be constantly maintained to the specified dimensions by adding rock. A stockpile shall be maintained on-site for this purpose. All sediment deposited on paved roadways shall be removed and returned to the construction site immediately. If excessive amounts of sediment are being deposited on roadway, extend length of rock construction entrance by 50-foot increments until condition is alleviated or install wash rack. Washing the roadway or sweeping the deposits into roadway ditches, sewers, culverts, or other drainage courses is not acceptable.

Figure 16. Standard Construction Detail for Rock Construction Entrance

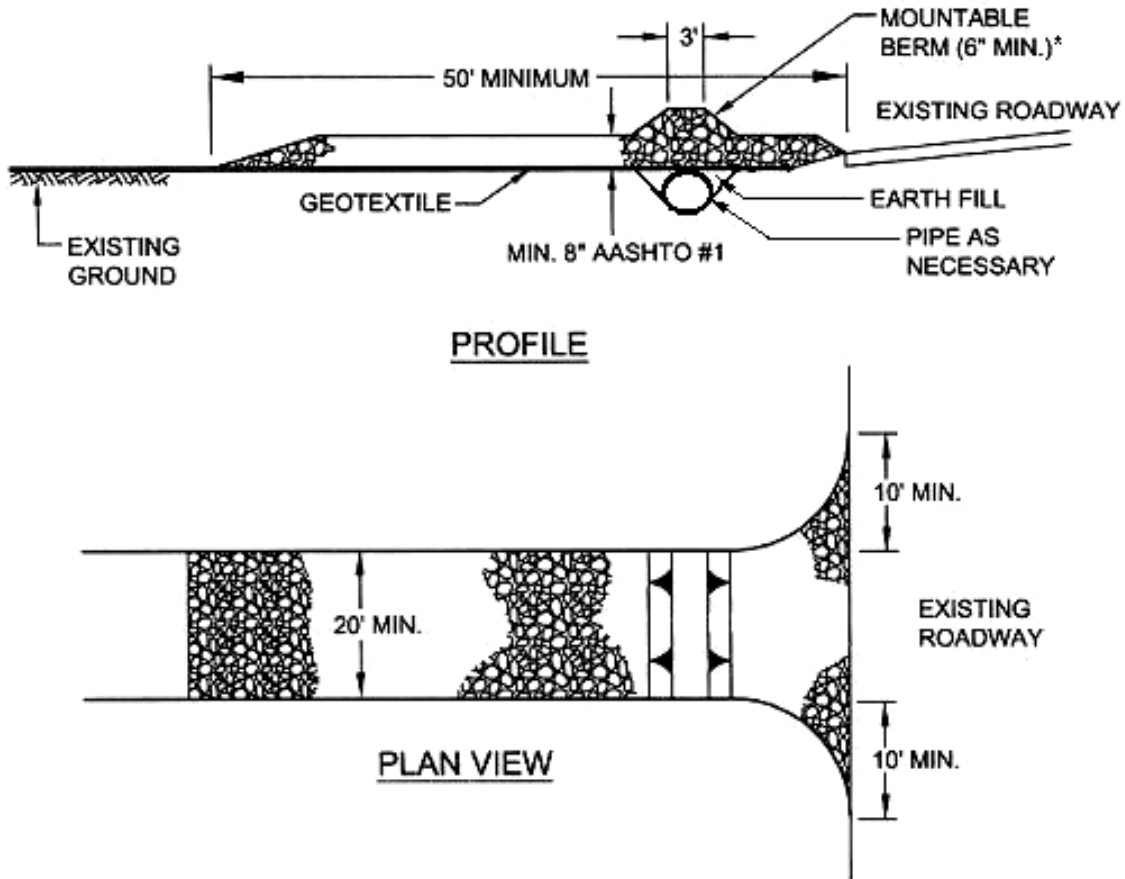

* MOUNTABLE BERM USED TO PROVIDE PROPER COVER FOR PIPE

12. Disturbed Area Stabilization

As soon as slopes, channels, ditches, and other disturbed areas reach final grade they must be stabilized. Upon completion or temporary cessation of the earth disturbance activity in a special protection watershed, that portion of the project site tributary to the special protection waters must be immediately stabilized. In all other watersheds, cessation of an activity for at least 4 days requires temporary stabilization. Keeping stabilization current with earthmoving is recommended for all projects, regardless of watershed classification.

All critical areas (disturbed areas that poses the greatest threat of sediment pollution to a receiving water; such as within floodways, within 50 ft of a wetland, slopes 3H:1V or steeper and erodible soils) that have not otherwise been stabilized and have significant potential for erosion should be stabilized with vegetation. Temporary erosion control BMPs that were installed for earthmoving activities must remain in place and be maintained in working order until permanent stabilization is achieved. NOTE: Areas that do not receive sufficient sunlight to support vegetation (e.g. under bridge decks) should be stabilized by some means other than vegetation.

Refer to **Tables 8 and 9** for recommended seed mix and seeding rate to be used on critical areas.

Table 8. Recommended Seed Mixtures ¹

Mixture Number	Species	Seeding Rate - Pure Live Seed ²	
		Most Sites	Adverse Sites
1 ³	Creeping red fescue, or	20	25
	Kentucky bluegrass, plus	20	25
	Redtop ⁴ , or	3	5
	Perennial ryegrass	15	20
2	Birdsfoot trefoil, plus	6	10
	Tall fescue	20	25
3	Orchardgrass, plus	15	20
	Perennial ryegrass, plus	15	20
	Birdsfoot trefoil	6	10
4 ⁵	Switchgrass, or	10	15
	Indiangrass, plus	10	15
	Partridge pea	5	10
5 ⁶	Birdsfoot trefoil, plus	6	10
	Timothy, or	20	25
	Perennial ryegrass	20	25

Penn State, "Erosion Control and Conservation Plantings on Noncropland"

- ¹ Seed and mulch disturbed areas with recommended seed mixtures appropriate for site conditions and further identified in Tables 11.3, 11.4 and 11.5 of the Department's Erosion and Sediment Pollution Control Program Manual
- ² PLS is the product of the percentage of pure seed times percentage germination divided by 100. For example, to secure the actual planting rate for switchgrass, divide 12 pounds PLS shown on the seed tag. Thus, if the PLS content of a given seed lot is 35%, divide 12 PLS by 0.35 to obtain 34.3 pounds of seed required to plant one acre. All mixtures in this table are shown in terms of PLS.
- ³ This mixture is suitable for frequent mowing. Do not cut shorter than 4 inches.
- ⁴ Keep seeding rate to that recommended in table. These species have many seeds per pound and are very competitive. To seed small quantities of small seeds mix with equal parts sand or cat litter to ensure even spreading.
- ⁵ This mix contains only species that are native to Pennsylvania.
- ⁶ Do not mow shorter than 9 to 10 inches.

Table 9. Recommended Seed Mixtures for Stabilizing Disturbed Areas

Site Condition	Nurse Crop ¹	Seed Mixture (Select one mixture)
Slopes and Banks (not mowed)		
Well-drained	1 plus	1, 2, 3, 4 or 5
Variable drainage	1 plus	1, 3 or 5
Slopes and Banks (mowed)		
Well-drained	1 plus	1 or 2
Slopes and Banks (grazed/hay)		
Well-drained	1 plus	3, 4 or 5
Gullies and Eroded Areas	1 plus	1 or 2
Erosion Control Facilities (BMPs)		
Sod waterways, spillways, frequent water flow areas	1 plus	1 or 2
Drainage ditches		
Shallow, less than 3 feet deep	1 plus	1, 2 or 5
Deep, not mowed	1 plus	1 or 2
Pond banks, dikes, levees, dams, diversion channels, and occasional water flow areas		
Mowed areas	1 plus	1, 2 or 3
Non-mowed areas	1 plus	4 or 5
For hay or silage on diversion channels and occasional water flow areas	1 plus	2 or 9

Penn State, "Erosion Control and Conservation Plantings on Noncropland"

¹ Nurse Crops should be added to all mixes to improve soil stabilization and increase the chance of establishment. Nurse crops can be mixed in with the desired seed mix. When using in combination with another mix, they should be applied at a rate of 1 bushel (~30lbs) per acre. If used alone on a site, they should be applied at 2 bushels (~60lbs) per acre. Use Spring oats (*Avena fatua*) if seeding prior to August 15th and use Winter rye (*Secale cereale*) if seeding after August 15th. Annual rye (*Lolium multiflorum*) may be used instead of oats or winter rye if desired.

C. Site Maintenance

DEP’s regulations in Chapter 102 require that the E&S Plan include a maintenance program. That maintenance program must require that all BMPs be inspected and maintained on a weekly basis and after each stormwater event (e.g., precipitation in an amount of 0.25 inch or greater over a 24-hour period) to ensure effective and efficient operation. Follow the maintenance criteria specified for each BMP listed in Section IV.B. of this guide or as identified on the E&S Plan. Note that maintenance requirements must be specified in written E&S Plans. Written documentation of these inspections and any maintenance/replacements must be maintained. A timber harvesting BMP inspection template, is available online through the Pennsylvania SFI Implementation Committee website (<https://www.sfiopa.org/forms.php>). Individuals should review this template before use to ensure that it will meet the requirements of DEP regulations as applied to their particular operation,



SFI of PA Website

- Protection should be maintained around seeps, wetlands, soaks, and springs near earth disturbance areas.
- Haul roads and skid roads will be repaired where signs of accelerated erosion are detected. Maintenance of haul roads may be reduced if they are allowed to settle a few months between construction and use, and if overhanging trees are removed to enable sunlight and wind to dry the haul roads.
- Seeding and mulching will be repeated in those areas that appear to be failing or have failed.
- Materials removed from BMPs should be replaced outside any floodways, wetlands, or waters of the Commonwealth.
- Inspect drainage structures frequently. Immediately make necessary repairs and clear any obstruction.

- Grade occasionally with a motor grader, bulldozer or road drag to maintain haul road surfaces. Proper grading will reshape dips, improve and reestablish side ditches and remove ruts from the haul road surface.
- Reducing or eliminating traffic on haul roads, skid trails and landings during unfavorable weather is important. Controlling erosion on unsurfaced roads is impossible if the roads are used during excessively wet weather. The most likely time for excessive road damage is when a frozen road surface thaws. Suspending or minimizing hauling operations during this period helps to avoid severe damage to the road surface.
- Consider adding an access gate to limit traffic, if necessary. A durable gate can be one of the most important structures for protecting a haul road system.

D. Winter Harvests

Timber harvests are often conducted during the winter months to take advantage of frozen ground. While this practice is encouraged, there are a few concerns that should be addressed:

- Before it snows, mark existing culverts and other drainage structures as well as waterways and wetlands, which can be obscured by snowfall. Keep all drainage structures open and functioning properly.
- Wherever haul roads and skid roads are constructed over soils with low strength, as identified in Appendix E in DEP's E&S Manual, hauling and skidding should be limited to periods when temperatures are below freezing unless these roads have been engineered to withstand the equipment weights involved.
- During cold weather, snow should be plowed from haul roads and skid roads to facilitate freezing of the road grade before hauling.
- Operations should be suspended during thaw cycles, winter rains, and during times of heavy snow melt when soils tend to be saturated.
- During times of heavy snow, provide breaks in snow berms along plowed roads to facilitate drainage.
- Compact skid trail snow before skidding logs. This will help protect soils that are not completely frozen.

V. SITE RETIREMENT

When a tract or parcel within a harvest area has been completed, all haul roads, skid trails, and landings associated with that tract or parcel should be retired; even while timbering continues on other tracts and parcels. To do so, the following guidelines are recommended:

- Regrade all road and landing surfaces to approximate original contour. Scarify compacted soils in preparation for seeding.
- Remove ditch relief culverts and replace them with waterbars or broad-based dips.
- Remove all temporary stream and wetland crossings and stabilize disturbed areas. Install or restore waterbars at appropriate distances on the approaches to the stream crossings.
- Seed and mulch disturbed areas with seed mixtures appropriate for site conditions, such as shade tolerant, steep slope mixture, acid tolerant, etc. and further identified in Tables 11.3, 11.4 and 11.5 in DEP's E&S Manual. Blanket disturbed areas with a slope of 3H:1V or steeper, within 50 feet of stream channels or wetlands, and within 100 feet of a special protection surface water.

Individuals responsible for earth disturbance activities must ensure that proper mechanisms are in place to control waste materials. Measures should be planned and implemented for housekeeping, materials management, and litter control. Whenever possible, recycling of excess materials is preferred, rather than disposal. Timber harvesting E&S Plans should address procedures which ensure proper measures for recycling or disposal of materials associated with or from the project site.

Wherever heavy equipment will be used during timber harvesting activities, a Preparedness, Prevention and Contingency (PPC) plan must be available on site. The purpose of these plans is to prevent and control accidental discharges of polluting materials to surface or groundwater. These plans address the storage, use, or transportation of materials including: fuels, chemicals, solvents, pesticides, fertilizers, lime, petrochemicals, wastewater, wash water, solid wastes, or hazardous materials onto, on, or from the project site during earth disturbance activities. The PPC plan must be available upon request by DEP or conservation district. A sample PPC plan template for timber harvesting activities is available online through the Pennsylvania SFI Implementation Committee website (<https://www.sfiopa.org/forms.php>). Individuals should review this template before use to ensure that it will meet the requirements of DEP regulations as applied to their particular operation. The template plan is designed to be used in conjunction with DEP's Erosion and Sediment Control Plan Template for a Timber Harvesting Operation (DEP Document ID# 3800-FM-BCW0539). Additional information related to PPC plans can be found in the Department's Guidelines for the Development and Implementation of Environmental Emergency Response Plans (DEP Document ID# 400-2200-001).

DRAFT

APPENDIX A: Checklist for Wetlands Protection

REFER TO TOPOGRAPHICAL MAPS, WETLAND MAPS, AERIAL IMAGERY, AND SOIL SURVEYS

_____ note any areas that indicate the presence of wetlands or hydric soils

CONDUCT AN ON-SITE INSPECTION

_____ determine the boundaries of any wetlands indicated on the maps and aerial images

_____ Confirm wetland presence and identify additional wetlands (Most are not depicted on maps) using the Army Corps of Engineers Wetland Delineation Manual and the appropriate regional supplements. https://www.usace.army.mil/Missions/Civil-Works/Regulatory-Program-and-Permits/reg_supp/

_____ determine the approximate boundaries of any additional wetlands; include stream locations

_____ consult your DEP Regional Office if you have questions

INCORPORATE WETLANDS INTO HARVESTING PLAN

_____ follow Pennsylvania's erosion and sediment control requirements

_____ avoid crossing wetlands and stream channels

_____ consult your DEP Regional Office if wetland and stream crossings cannot be avoided

_____ minimize timber harvest in wetland, avoid harvesting In EV wetlands and Vernal Pools

DEVELOP A WORKING KNOWLEDGE OF FEDERAL AND STATE REGULATIONS

_____ know regulations prior to start-up of operations

_____ understand the permitting process to determine if any permits are required

_____ avoid wetlands and streams to minimize regulatory permit requirements

USE BEST MANAGEMENT PRACTICES

_____ to maintain forest productivity

_____ to protect valuable wetlands

_____ to ensure compliance with state and federal regulation

_____ to improve public acceptance of forest management and harvesting

APPENDIX B: List of Common Pennsylvania Wetland Plants

LIST OF TREES AND SHRUBS

Common Name	Scientific Name
alder	<i>Alnus rugosa</i>
arrow-wood, northern	<i>Viburnum recognitum</i>
ash, green	<i>Fraxinus pennsylvanica</i>
birch, river	<i>Betula nigra</i>
blueberry, highbush	<i>Vaccinium corymbosum</i>
dogwood, red-osier	<i>Cornus stolonifera</i>
dogwood, silky	<i>Cornus amomum</i>
elderberry, common	<i>Sambucus canadensis</i>
elm, American	<i>Ulmus americana</i>
leatherleaf	<i>Chamaedaphne calyculata</i>
maple, silver	<i>Acer saccharinum</i>
maple, box elder	<i>Acer negundo</i>
meadowsweet, broad-leaved	<i>Spirea latifolia</i>
meadowsweet, narrow-leaved	<i>Spirea alba</i>
oak, pin	<i>Quercus palustris</i>
oak, swamp white	<i>Quercus bicolor</i>
spicebush, northern	<i>Lindera benzoin</i>
steeply-bush	<i>Spirea tomentosa</i>
sumac, poison	<i>Toxicodendron vernix</i>
sycamore	<i>Platanus occidentalis</i>
willow, black	<i>Salix nigra</i>
willow, silky	<i>Salix sericea</i>

Appendix B (Continued)

LIST OF HERBACEOUS SPECIES

Common Name	Scientific Name
arrow arum	<i>Peltandra virginica</i>
arrowhead, broad-leaved	<i>Sagittaria latifolia</i>
blue vervain	<i>Verbena hastata</i>
boneset, common	<i>Eupatorium perfoliatum</i>
bulrush, green	<i>Scirpus atrovirens</i>
button bush	<i>Cephalanthus occidentalis</i>
bur-reed, eastern	<i>Sparganium americanum</i>
cardinal flower	<i>Lobelia cardinalis</i>
cattail, broad-leaved	<i>Typha latifolia</i>
common reed	<i>Phragmites australis</i>
fern, sensitive	<i>Onoclea sensibilis</i>
grass, bluejoint	<i>Calamagrostis canadensis</i>
grass, manna	<i>Glyceria canadensis</i>
grass, reed canary	<i>Phalaris arundinacea</i>
grass, rice cut-	<i>Leersia oryzoides</i>
grass, wool	<i>Scirpus cyperinus</i>
iris, blue flag	<i>Iris versicolor</i>
jack-in-the-pulpit	<i>Arisaema triphyllum</i>
jewelweed, spotted	<i>Impatiens capensis</i>
Joe-Pye-weed, spotted	<i>Eupatorium maculatum</i>
lily, yellow pond	<i>Nuphar lutea</i>
lily, white water	<i>Nymphaea odorata</i>
marsh marigold	<i>Caltha palustris</i>
nettle, false	<i>Boehmeria cylindrical</i>
pickerelweed	<i>Pontederia cordata</i>
pitcher plant, northern	<i>Sarracenia purpurea</i>
Pondweeds	<i>Potamogeton spp.</i>
rush, soft	<i>Juncus effusus</i>
sedge, three-way	<i>Dulichium arundinaceum</i>
sedge, tussock	<i>Carex stricta</i>
skunk cabbage	<i>Symplocarpus foetidus</i>
smartweed, arrow-leaved	<i>Polygonum sagittatum</i>
smartweed, mild water pepper	<i>Polygonum hydropiperoides</i>
sphagnum moss	<i>Sphagnum spp.</i>
spikerush, blunt	<i>Eleocharis obtusa</i>
Sundews	<i>Drosera spp.</i>
sweetflag	<i>Acorus calamus</i>
water shield	<i>Brasenia schreberi</i>
water calla	<i>Calla palustris</i>
wild rice	<i>Zazania aquatica</i>

APPENDIX C: Contact Information

STATE

PA Department of Environmental Protection - Central Office

Bureau of Clean Water
Division of NPDES Permitting
PO Box 8774
Harrisburg, PA 17105-8774
(717) 787-5017

Bureau of Waterway Engineering and Wetlands
Division of Wetlands, Encroachments and Training
P.O. Box 8554
Harrisburg, PA 17105-8554

Regional offices of Waterways and Wetlands Program process all permits, register general permits, handle enforcement and coordinate with county conservation districts.

PA Department of Environmental Protection - Regional Offices

Southeast Region

2 East Main Street
Norristown, PA 19401
484-250-5970

Counties: Bucks, Chester, Delaware, Montgomery and Philadelphia

Southwest Region

400 Waterfront Drive
Pittsburgh, PA 15222-4745
412-442-4000

Counties: Allegheny, Beaver, Cambria, Fayette, Greene, Somerset, Washington and Westmoreland

Northeast Region

2 Public Square
Wilkes-Barre, PA 18711-0790
570-826-2511

Counties: Carbon, Lackawanna, Lehigh, Luzerne, Monroe, Northampton, Pike, Schuylkill, Susquehanna, Wayne & Wyoming

Northwest Region

230 Chestnut Street
Meadville, PA 16335-3481
814-332-6984

Counties: Armstrong, Butler, Clarion, Crawford, Elk, Erie, Forest, Indiana, Jefferson, Lawrence, McKean, Mercer, Venango and Warren

Northcentral Region

208 W. Third Street, Suite 101
Williamsport, PA 17701
570-327-3574

Counties: Bradford, Cameron, Clearfield, Centre, Clinton, Columbia, Lycoming, Montour, Northumberland, Potter, Snyder, Sullivan, Tioga and Union

Southcentral Region

909 Elmerton Avenue
Harrisburg, PA 17110
717-705-4707

Counties: Adams, Bedford, Berks, Blair, Cumberland, Dauphin, Franklin, Fulton, Huntingdon, Juniata, Lancaster, Lebanon, Mifflin, Perry and York

Appendix C (Continued)

Additional Bureaus and Agencies of State Government

Bureau of Forestry
PO Box 8552
Harrisburg, PA 17105-8552
(717) 787-3444
Administers PA natural diversity inventory

PA Fish and Boat Commission
PO Box 67000
Harrisburg, PA 17106
(717) 705-7800
Enforces Clean Stream Law, conducts waterways conservation, comments on major permit applications

PA Game Commission
2001 Elmerton Ave.
Harrisburg, PA 17110-9797
(717) 787-4250
Regulates the harvest and control of wild animal species and manages their habitat and comments on major permit applications

LOCAL AND OTHER

County Conservation Districts
Consult PACD's website (www.pacd.org, Find Your Conservation District), for contact information

Cartographic Information Research Center
102-D Hasbrouck Lab
University of Massachusetts
Amherst, MA 01003
(413) 545-0359
Distributes NWI maps for PA

Chapter 105 Delegated County Conservation Districts can be found here:
<http://www.depgreenport.state.pa.us/elibrary/GetFolder?FolderID=4055>

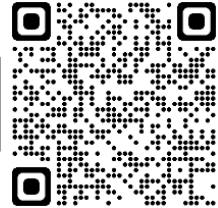

APPENDIX D: Matrices for Calculating Acres of Disturbance

		Width of Disturbed Area(ft)								
		20	40	60	80	100	120	140	180	200
Length of Disturbed Area(ft)	20	0.009	0.018	0.028	0.037	0.046	0.055	0.064	0.083	0.092
	30	0.014	0.028	0.041	0.055	0.069	0.083	0.096	0.124	0.138
	40	0.018	0.037	0.055	0.073	0.092	0.110	0.129	0.165	0.184
	50	0.023	0.046	0.069	0.092	0.115	0.138	0.161	0.207	0.230
	60	0.028	0.055	0.083	0.110	0.138	0.165	0.193	0.248	0.275
	70	0.032	0.064	0.096	0.129	0.161	0.193	0.225	0.289	0.321
	80	0.037	0.073	0.110	0.147	0.184	0.220	0.257	0.331	0.367
	90	0.041	0.083	0.124	0.165	0.207	0.248	0.289	0.372	0.413
	100	0.046	0.092	0.138	0.184	0.230	0.275	0.321	0.413	0.459
	110	0.051	0.101	0.152	0.202	0.253	0.303	0.354	0.455	0.505
	120	0.055	0.110	0.165	0.220	0.275	0.331	0.386	0.496	0.551
	130	0.060	0.119	0.179	0.239	0.298	0.358	0.418	0.537	0.597
	140	0.064	0.129	0.193	0.257	0.321	0.386	0.450	0.579	0.643
	150	0.069	0.138	0.207	0.275	0.344	0.413	0.482	0.620	0.689
	160	0.073	0.147	0.220	0.294	0.367	0.441	0.514	0.661	0.735
	170	0.078	0.156	0.234	0.312	0.390	0.468	0.546	0.702	0.781
	180	0.083	0.165	0.248	0.331	0.413	0.496	0.579	0.744	0.826
	190	0.087	0.174	0.262	0.349	0.436	0.523	0.611	0.785	0.872
	200	0.092	0.184	0.275	0.367	0.459	0.551	0.643	0.826	0.918
	210	0.096	0.193	0.289	0.386	0.482	0.579	0.675	0.868	0.964
	220	0.101	0.202	0.303	0.404	0.505	0.606	0.707	0.909	1.010
	230	0.106	0.211	0.317	0.422	0.528	0.634	0.739	0.950	1.056
	240	0.110	0.220	0.331	0.441	0.551	0.661	0.771	0.992	1.102
	250	0.115	0.230	0.344	0.459	0.574	0.689	0.803	1.033	1.148
	260	0.119	0.239	0.358	0.478	0.597	0.716	0.836	1.074	1.194
	270	0.124	0.248	0.372	0.496	0.620	0.744	0.868	1.116	1.240
	280	0.129	0.257	0.386	0.514	0.643	0.771	0.900	1.157	1.286
	290	0.133	0.266	0.399	0.533	0.666	0.799	0.932	1.198	1.331
	300	0.138	0.275	0.413	0.551	0.689	0.826	0.964	1.240	1.377
	310	0.142	0.285	0.427	0.569	0.712	0.854	0.996	1.281	1.423
	320	0.147	0.294	0.441	0.588	0.735	0.882	1.028	1.322	1.469
	330	0.152	0.303	0.455	0.606	0.758	0.909	1.061	1.364	1.515
	340	0.156	0.312	0.468	0.624	0.781	0.937	1.093	1.405	1.561
	350	0.161	0.321	0.482	0.643	0.803	0.964	1.125	1.446	1.607
	360	0.165	0.331	0.496	0.661	0.826	0.992	1.157	1.488	1.653
	370	0.170	0.340	0.510	0.680	0.849	1.019	1.189	1.529	1.699
	380	0.174	0.349	0.523	0.698	0.872	1.047	1.221	1.570	1.745
	390	0.179	0.358	0.537	0.716	0.895	1.074	1.253	1.612	1.791
	400	0.184	0.367	0.551	0.735	0.918	1.102	1.286	1.653	1.837

Areas listed in the table are in acres

Appendix D (Continued)

		Width of Skid Road or Haul Road (ft)									
		8	10	12	14	16	20	25	30	35	40
Length of Skid Road or Haul Road (ft)	50	0.009	0.011	0.014	0.016	0.018	0.023	0.029	0.034	0.040	0.046
	100	0.018	0.023	0.028	0.032	0.037	0.046	0.057	0.069	0.080	0.092
	150	0.028	0.034	0.041	0.048	0.055	0.069	0.086	0.103	0.121	0.138
	200	0.037	0.046	0.055	0.064	0.073	0.092	0.115	0.138	0.161	0.184
	250	0.046	0.057	0.069	0.080	0.092	0.115	0.143	0.172	0.201	0.230
	300	0.055	0.069	0.083	0.096	0.110	0.138	0.172	0.207	0.241	0.275
	350	0.064	0.080	0.096	0.112	0.129	0.161	0.201	0.241	0.281	0.321
	400	0.073	0.092	0.110	0.129	0.147	0.184	0.230	0.275	0.321	0.367
	450	0.083	0.103	0.124	0.145	0.165	0.207	0.258	0.310	0.362	0.413
	500	0.092	0.115	0.138	0.161	0.184	0.230	0.287	0.344	0.402	0.459
	550	0.101	0.126	0.152	0.177	0.202	0.253	0.316	0.379	0.442	0.505
	600	0.110	0.138	0.165	0.193	0.220	0.275	0.344	0.413	0.482	0.551
	650	0.119	0.149	0.179	0.209	0.239	0.298	0.373	0.448	0.522	0.597
	700	0.129	0.161	0.193	0.225	0.257	0.321	0.402	0.482	0.562	0.643
	750	0.138	0.172	0.207	0.241	0.275	0.344	0.430	0.517	0.603	0.689
	800	0.147	0.184	0.220	0.257	0.294	0.367	0.459	0.551	0.643	0.735
	850	0.156	0.195	0.234	0.273	0.312	0.390	0.488	0.585	0.683	0.781
	900	0.165	0.207	0.248	0.289	0.331	0.413	0.517	0.620	0.723	0.826
	950	0.174	0.218	0.262	0.305	0.349	0.436	0.545	0.654	0.763	0.872
	1000	0.184	0.230	0.275	0.321	0.367	0.459	0.574	0.689	0.803	0.918
1050	0.193	0.241	0.289	0.337	0.386	0.482	0.603	0.723	0.844	0.964	
1100	0.202	0.253	0.303	0.354	0.404	0.505	0.631	0.758	0.884	1.010	
1150	0.211	0.264	0.317	0.370	0.422	0.528	0.660	0.792	0.924	1.056	
1200	0.220	0.275	0.331	0.386	0.441	0.551	0.689	0.826	0.964	1.102	
1250	0.230	0.287	0.344	0.402	0.459	0.574	0.717	0.861	1.004	1.148	
1300	0.239	0.298	0.358	0.418	0.478	0.597	0.746	0.895	1.045	1.194	
1350	0.248	0.310	0.372	0.434	0.496	0.620	0.775	0.930	1.085	1.240	
1400	0.257	0.321	0.386	0.450	0.514	0.643	0.803	0.964	1.125	1.286	
1450	0.266	0.333	0.399	0.466	0.533	0.666	0.832	0.999	1.165	1.331	
1500	0.275	0.344	0.413	0.482	0.551	0.689	0.861	1.033	1.205	1.377	
1550	0.285	0.356	0.427	0.498	0.569	0.712	0.890	1.067	1.245	1.423	
1600	0.294	0.367	0.441	0.514	0.588	0.735	0.918	1.102	1.286	1.469	
1650	0.303	0.379	0.455	0.530	0.606	0.758	0.947	1.136	1.326	1.515	
1700	0.312	0.390	0.468	0.546	0.624	0.781	0.976	1.171	1.366	1.561	
1750	0.321	0.402	0.482	0.562	0.643	0.803	1.004	1.205	1.406	1.607	
1800	0.331	0.413	0.496	0.579	0.661	0.826	1.033	1.240	1.446	1.653	
1850	0.340	0.425	0.510	0.595	0.680	0.849	1.062	1.274	1.486	1.699	
1900	0.349	0.436	0.523	0.611	0.698	0.872	1.090	1.309	1.527	1.745	

Areas listed in the table are in acres

APPENDIX E: Key Federal Regulations for Section 404 of the Clean Water Act

For the most recent definition of Waters of the United States and other Federal Clean Water Act and the National Waters Protection Rule see the following website:

<https://www.epa.gov/cwa-404>



EPA Website on Section 404 of the Clean Water Act
[epa.gov/cwa-404](https://www.epa.gov/cwa-404)

For the most recent Section 404 regulations administered by the USACOE see the following website AND follow the link to 33 CFR Part 323:

<https://www.usace.army.mil/Missions/Civil-Works/Regulatory-Program-and-Permits/Federal-Regulation/>



USACOE Website on Section 404 permitting

EPA's website also contains the Clean Water Act Section 404(b)(1) guidelines at the following link:

<https://www.epa.gov/cwa-404/cwa-section-404b1-guidelines-40-cfr-230>

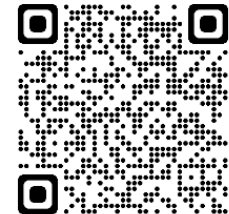

USEPA Website on Section 404 permitting

ACRONYMS

AASHTO - American Association of State Highway and Transportation Officials
ACRE - Agriculture, Communities and Rural Environment
ABACT - antidegradation best available combination of technologies
APR - acid producing rock
BMP - best management practices
CFR - code of federal regulations
CWA - Clean Water Act
DCNR - Department of Conservation and Natural Resources
DEP - Department of Environmental Protection
E&S - erosion and sediment control
EPA - Environmental Protection Agency
EV - Exceptional Value Waters
FEMA - Federal Emergency Management Agency
GP - general permit
HQ - High Quality Waters
MPC - municipalities planning code
NOI - notice of intent
NPDES - National Pollutant Discharge Elimination System
PASPGP - Pennsylvania state programmatic general permit
PFBC - Pennsylvania Fish and Boat Commission
PGC - Pennsylvania Game Commission
PLS - pure live seed
PNDI - Pennsylvania Natural Diversity Inventory
PNHP - Pennsylvania Natural Heritage Program
PPC - preparedness, prevention and contingency
SFI - Sustainable Forestry Initiative
T&E - threatened and endangered
USACOE - United States Army Corps of Engineers
USFWS - United States Fish and Wildlife Service
USGS - United States Geological Survey

REFERENCES

- Corps of Engineers Wetland Delineation Manual*. Environmental Laboratory Technical Report Y-87-1, US Army Corps of Engineers Waterways Experiment Station, Vicksburg, MS, 1987, 169 pp.
- Fisher, J. E., and D. W. Taber. *Logging Road and Skid Trail Construction*. State University of New York, Applied Forestry Research Institute, Misc. Report No. 6, 1975.
- Garland, John J. *Planning Woodland Roads*. Oregon State University Extension Service, Circular 1118, 1983.
- Garland, John J. *Road Construction on Woodland Properties*. Oregon State University Extension Service, Circular 1135, 1983.
- Garland, John J. *Designing Woodland Roads*. Oregon State University Extension Service, Circular 1137, 1983.
- Garland, John J. *Maintaining Woodland Roads*. Oregon State University Extension Service, Circular 1139, 1983.
- Hartung, Robert E., and James M. Kress, *Woodlands of the Northeast--Erosion and Sediment Control Guides*. USDA Soil Conservation Service and Forest Service, 1978.
- Hausman, Richard F., and Emerson W. Pruett. *Permanent Logging Roads for Better Woodlot Management*. State and Private Forestry, Northeastern Area, USDA Forest Service, 1978.
- Kochenderfer, James N. *Erosion Control on Logging Roads in the Appalachians*. Research Paper NE-158, Northeastern Forest Experiment Station, USDA Forest Service, 1970.
- Kochenderfer, James N., G. W. Wendel, and H. Clay Smith. *Cost of and Soil Loss on "Minimum-Standard" Forest Truck Roads Constructed in the Central Appalachians*. Research Paper NE-544, Northeastern Forest Experiment Station, USDA Forest Service, 1984.
- Northeast Forest Resources Extension Council Series. *A Guide to Logging Aesthetics – Practical Tips for Loggers, Foresters, and Landowners*. Northeast Regional Agricultural Engineering Service, Cooperative Extension, 1996.
- Pennsylvania Code, Title 25. Environmental Protection. Commonwealth of Pennsylvania, Dept. of Environmental Protection, Chapter 102. Erosion and Sediment Control*. Effective January 1, 2000, 18 pp.
- Pennsylvania Code, Title 25. Environmental Protection. Commonwealth of Pennsylvania, Dept. of Environmental Protection, Chapter 105. Dam Safety and Waterway Management*. Effective October 12, 1991, 261 pp.
- Pennsylvania Cooperative Extension Service. *Erosion Control and Conservation Plantings on Noncropland*. The Pennsylvania State University, College of Agricultural Sciences, 1997.
- Pennsylvania Department of Environmental Protection. *Soil Erosion and Sediment Pollution Control Program Manual*. Technical Guidance No. 363-2134-008, Bureau of Watershed Management, April 2000.
- Pennsylvania State University (PSU), College of Agricultural Sciences. *Best Management Practices for Pennsylvania Forests*. Forest Issues Working Group, PSU-School of Forest Resources, Pennsylvania Forest Stewardship Program, and Pennsylvania Hardwoods Development Council, 1996.

US Department of Agriculture (USDA), Natural Resource Conservation Service. *Engineering Field Manual for Conservation Practices*, March 1997.

US Environmental Protection Agency (USEPA). *Summary of Current State Nonpoint Source Control Practices for Forestry*. EPA-Office of Water, August 1993.

DRAFT