

EROSION & SEDIMENTATION CONTROL PLAN

PENNSYLVANIA PIPELINE PROJECT - TWIN OAKS STATION

UPPER CHICHESTER TOWNSHIP, DELAWARE COUNTY, PENNSYLVANIA

NOVEMBER 2016

PREPARED BY:

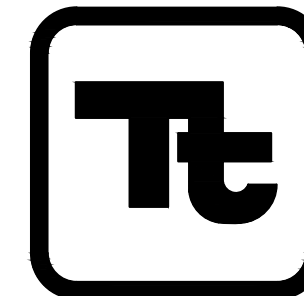

TETRA TECH

www.tetrattech.com

1134 TWIN STACKS DRIVE
DALLAS, PA 18612
T: (570) 674-8648 | F: (570) 674-8651
DATE: NOVEMBER 21, 2016
COVER SHEET 1 OF 9
REVISION #1 - 5/13/16
REVISION #2 - 10/10/16
REVISION #3 - 2/6/17

PREPARED FOR:
SUNOCO LOGISTICS PARTNERS L.P.
525 FRITZTOWN ROAD
SINKING SPRING, PENNSYLVANIA 19608
610-670-3200

DRAWING INDEX	
SHEET No.	DRAWING TITLE
1	COVER SHEET AND NOTES
2	EXISTING CONDITIONS
3	E&S CONTROL PLAN
4	DRAINAGE AREA MAP
5	PCSM PLAN
6	CONSTRUCTION DETAILS
7	CONSTRUCTION DETAILS
8	CONSTRUCTION DETAILS
9	CONSTRUCTION DETAILS

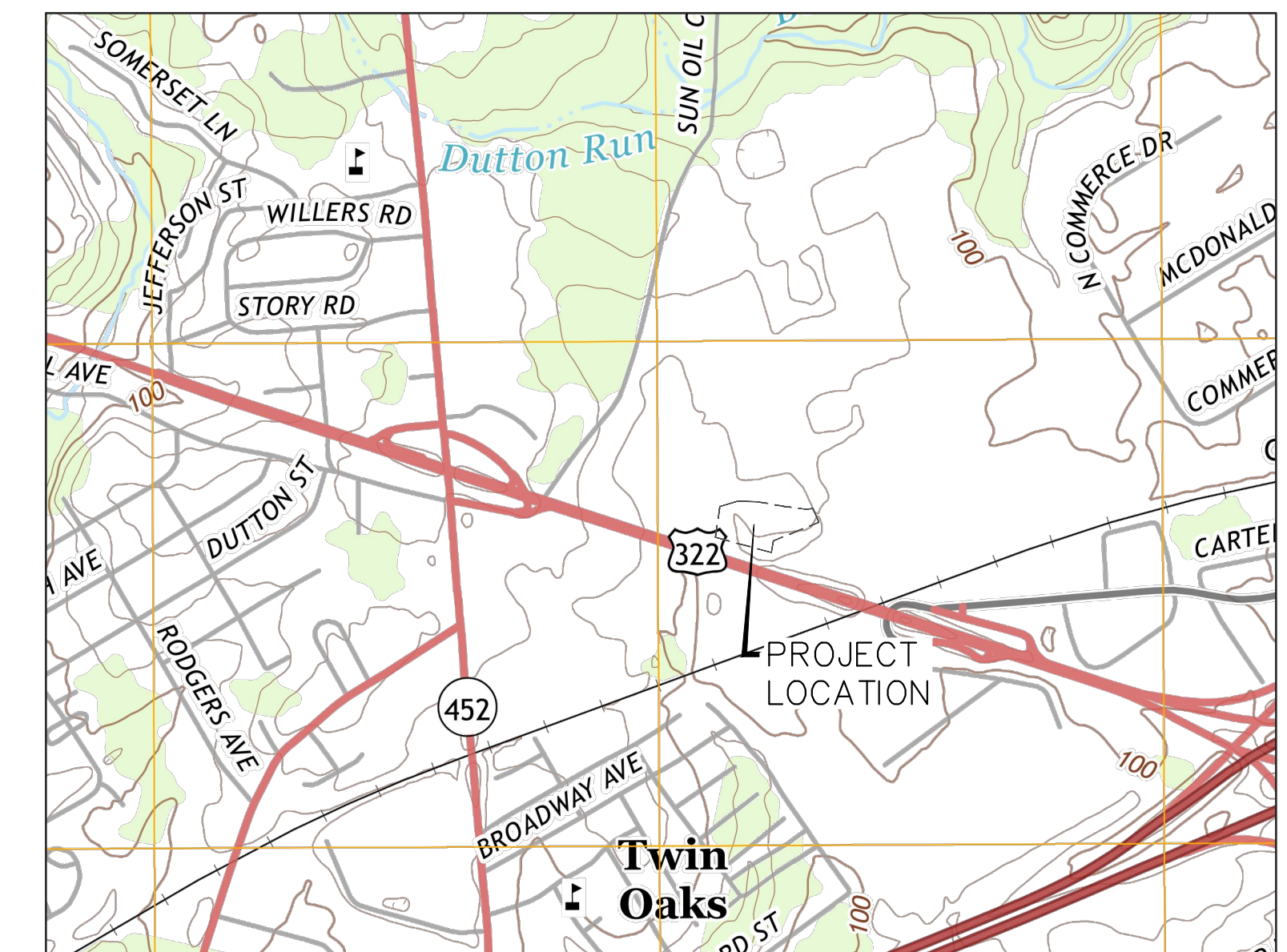

LOCATION MAP
TWIN OAKS STATION
MARCUS HOOK QUADRANGLE
UPPER CHICHESTER TOWNSHIP, DELAWARE COUNTY,
PENNSYLVANIA

0 1000 2000
SCALE IN FEET

GENERAL NOTES

1. DEVELOPER: SUNOCO LOGISTICS PARTNERS, LP
2. TAX ACCOUNT #: 09-00-01079-45
GIS TRACT PA-DE-0150.0000
FID # 2879
UGISID #182673
TOTAL PARCEL SIZE = 298.31 AC
3. PUBLIC SEWER AND WATER WILL NOT BE PROVIDED. FACILITY IS UNMANNED.
4. EXISTING CONTOURS AND FEATURES COMPILED FROM WWW.PASDA.PSU.EDU.
5. NO PORTION OF THE SITE LIES WITHIN ANY 100 YEAR FLOOD ZONES, AS PER F.E.M.A. MAPPING, FIRM PANEL 181 OF 250, MAP #42045C0181F, EFFECTIVE DATE IS 11/18/2009.
6. WETLANDS DELINEATED BY TETRA TECH, INC.
7. THE ASSOCIATED STORM WATER MANAGEMENT REPORT FOR THIS PROJECT IS TITLED:
EROSION AND SEDIMENTATION CONTROL PLAN
PENNSYLVANIA PIPELINE PROJECT
TWIN OAKS SUBSTATION
UPPER CHICHESTER TOWNSHIP
DELAWARE COUNTY
MARCH, 2016
8. THE SITE LIES WITHIN A 50% RELEASE RATE DISTRICT OF THE CHESTER CREEK ACT 167 STORMWATER MANAGEMENT PLAN.
9. CHESTER CREEK IS LISTED AS "MF" UNDER CHAPTER 93.

ENGINEER CERTIFICATION

I, TIMOTHY J. CONNOLLY JR., P.E., A LICENSED PROFESSIONAL ENGINEER IN THE COMMONWEALTH OF PENNSYLVANIA, DOES HEREBY CERTIFY THAT THE ACCOMPANYING APPLICATION, PLANS AND SUPPORTING DOCUMENTATION ARE TRUE AND ACCURATE, TO THE BEST OF MY KNOWLEDGE.

2/6/2017
DATE

TIMOTHY J. CONNOLLY JR., P.E.
PE-39066-E
1134 TWIN STACKS DRIVE, DALLAS, PA. 18612

LEGEND

- 112 --- EXISTING CONTOURS
- 106 --- PROPOSED CONTOURS
- FS --- FS --- FS --- FS --- FS --- FS --- FS --- FS --- 12" OR 24" HIGH COMPOST FILTER SOCK
- [Rock Pattern] --- STABILIZED ROCK CONSTRUCTION ENTRANCE
- LOD --- LOD --- LOD --- LOD --- LOD --- LOD --- LOD --- LOD --- LIMIT OF DISTURBANCE = 2.392 AC
- [Dotted Pattern] --- WETLAND AREA
- [Dashed Line] --- PRE-DEVELOPED DA
- [Dotted Line] --- POST-DEVELOPED DA
- [Dash-dot Line] --- TIME OF CONCENTRATION FLOW PATH
- [Solid Line] --- PROPERTY LINE
- LOD --- LOD --- LOD --- LOD --- LOD --- LOD --- LOD --- LOD --- ESCGP-2 BOUNDARY = 2.392 AC

CALL BEFORE YOU DIG!
PENNSYLVANIA LAW REQUIRES
3 WORKING DAYS NOTICE FOR
CONSTRUCTION PHASE AND 10 WORKING
DAYS IN DESIGN STAGE - STOP CALL
Pennsylvania One Call System, Inc.
 1-800-242-1776

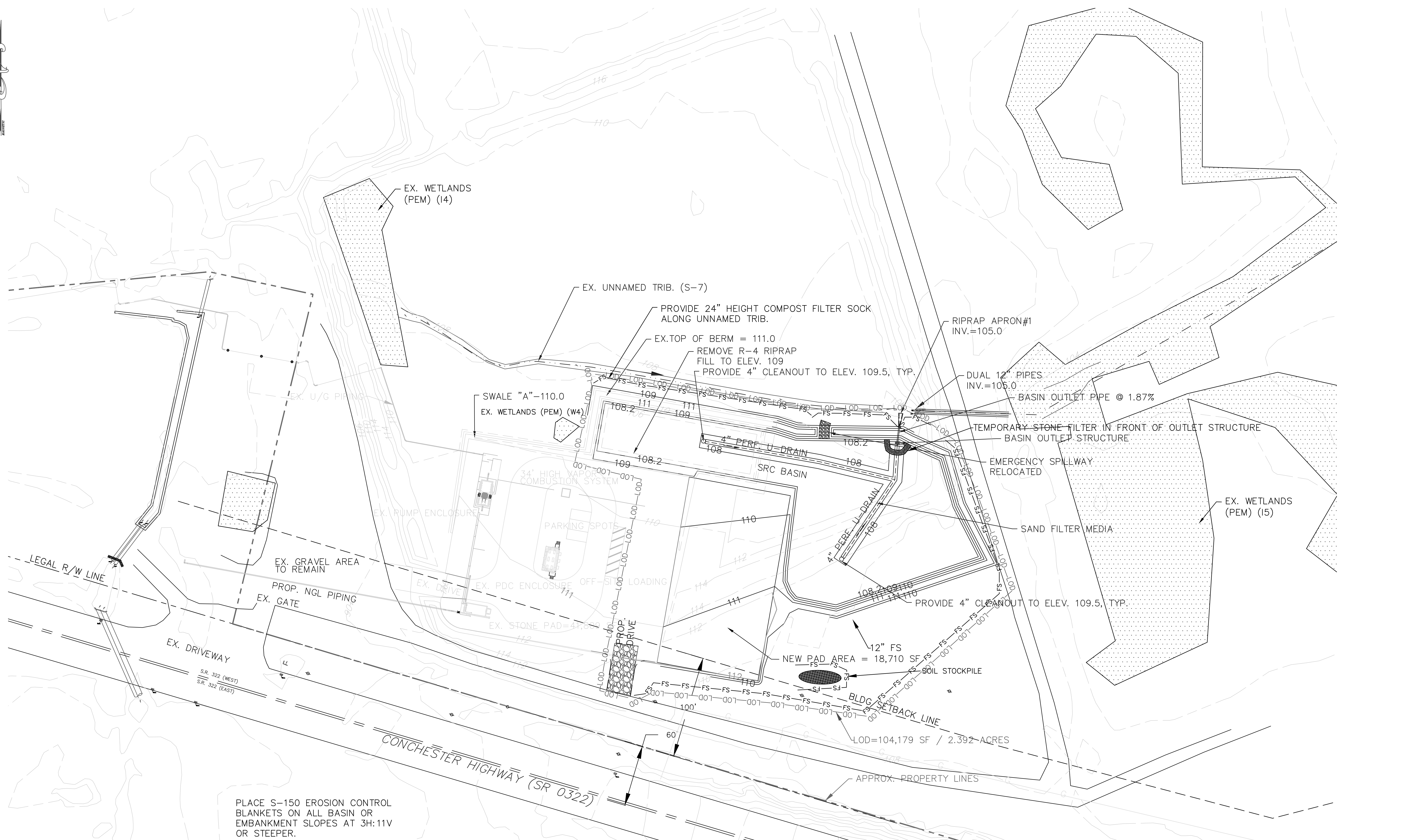

PLACE S-150 EROSION CONTROL BLANKETS ON ALL BASIN OR EMBANKMENT SLOPES AT 3H:11V OR STEEPER.

0 40 80
SCALE: 1"=40'

3
OF
9

TETRA TECH
www.tetrattech.com
1134 TWIN STACKS DRIVE
DALLAS, PA 18612
T: (570) 674-8648 | F: (570) 674-8651

MARK	DATE	DESCRIPTION	BY
1	5/13/16	REVISED PER DEP COMMENT LETTER (3/28/16)	GZ
2	10/10/16	REVISED PER DEP COMMENT LETTER (9/6/16)	GZ
3	2/4/17	REVISED PER DEP COMMENT LETTER (1/31/17)	TC

PPP - TWIN OAKS PUMP STATION
UPPER CHICHESTER TOWNSHIP, DELAWARE COUNTY

E&S PLAN - E&S CONTROL

DATE: 03/11/16
PROJECT NO.: IC-PB-00136
DRAWN BY: GZ
CHECKED BY: TC
SCALE: 1"=40'
FILE: TWIN OAKS
NAME: ES3
COPYRIGHT TETRA TECH INC.

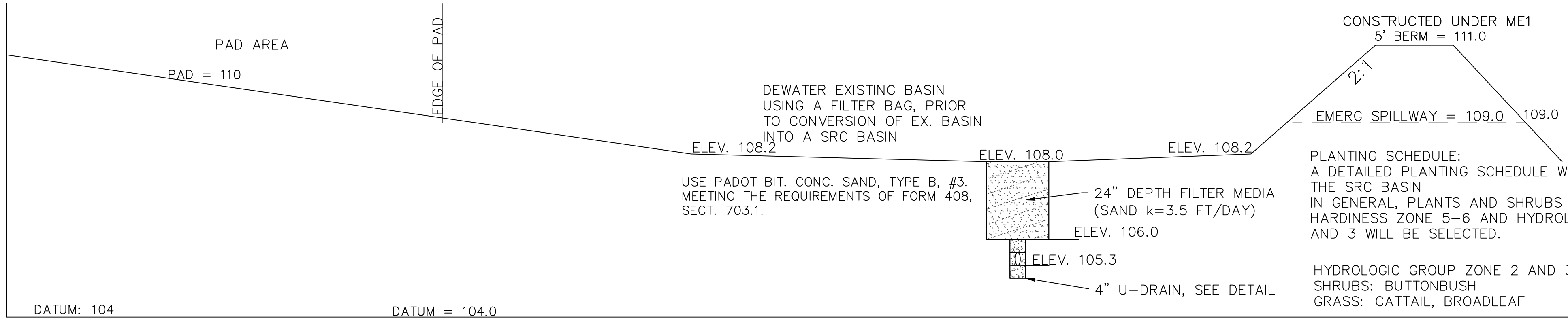

SECTION A-A THRU PROPOSED SRC BASIN

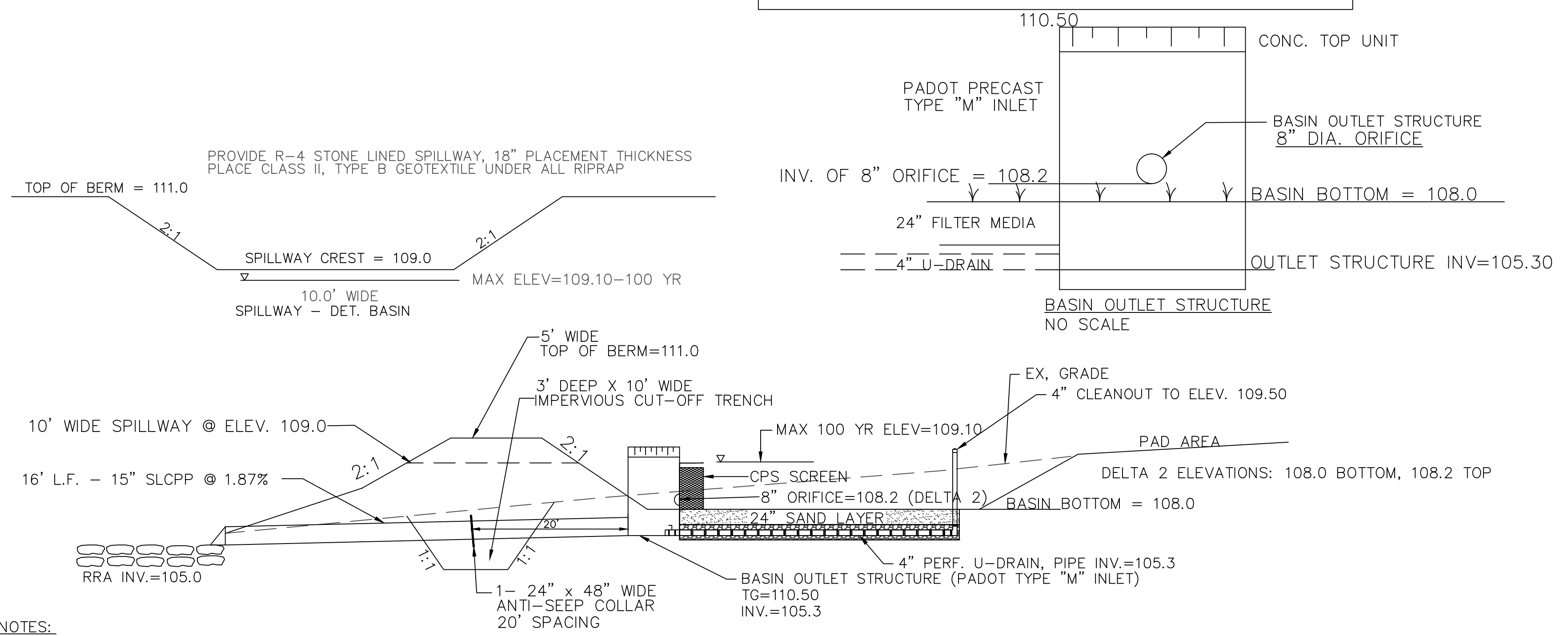
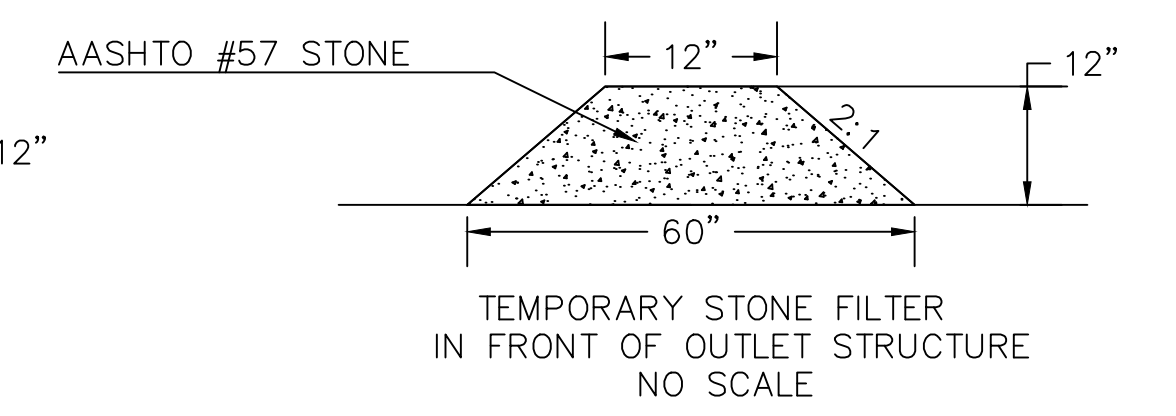
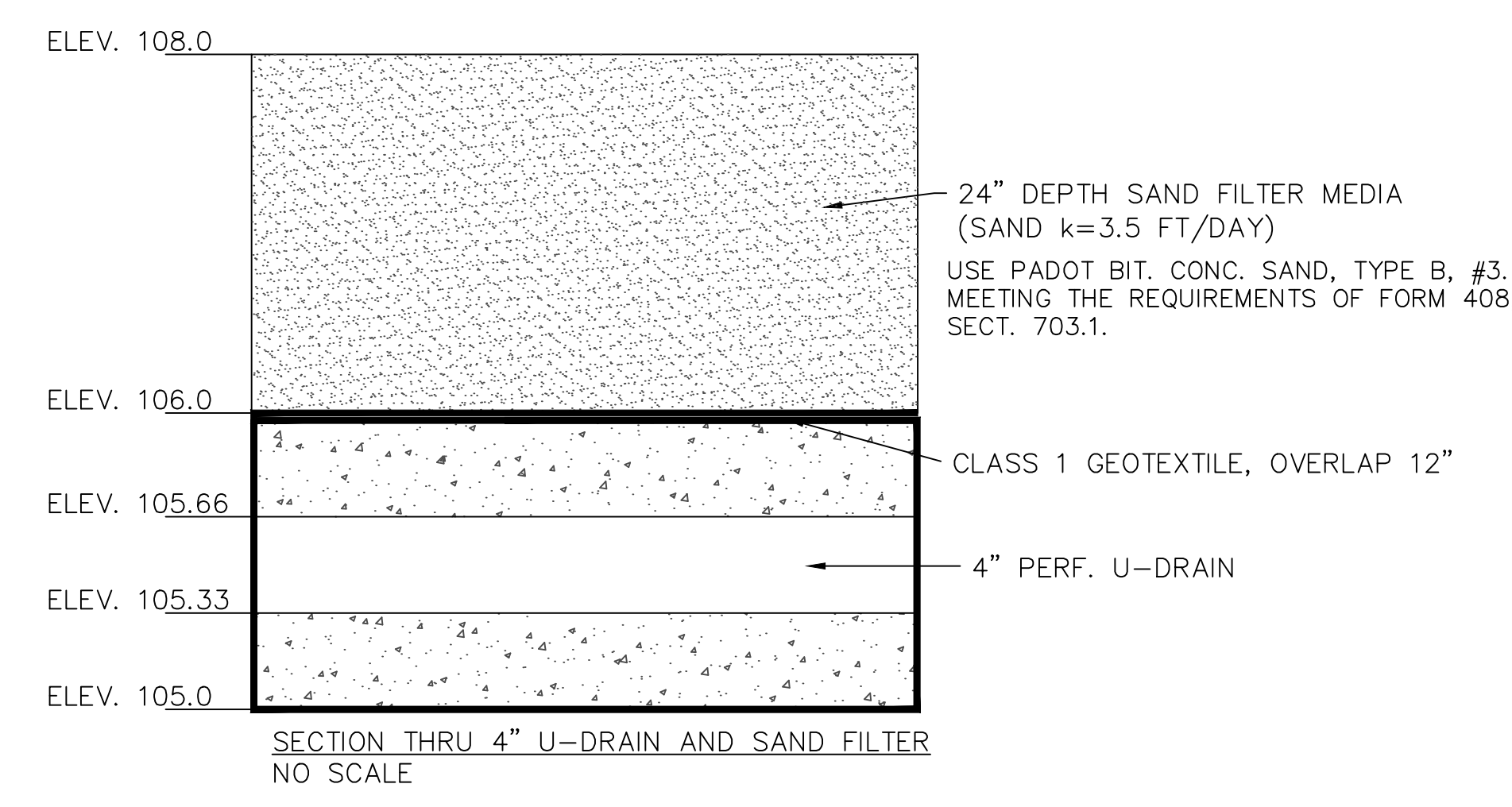
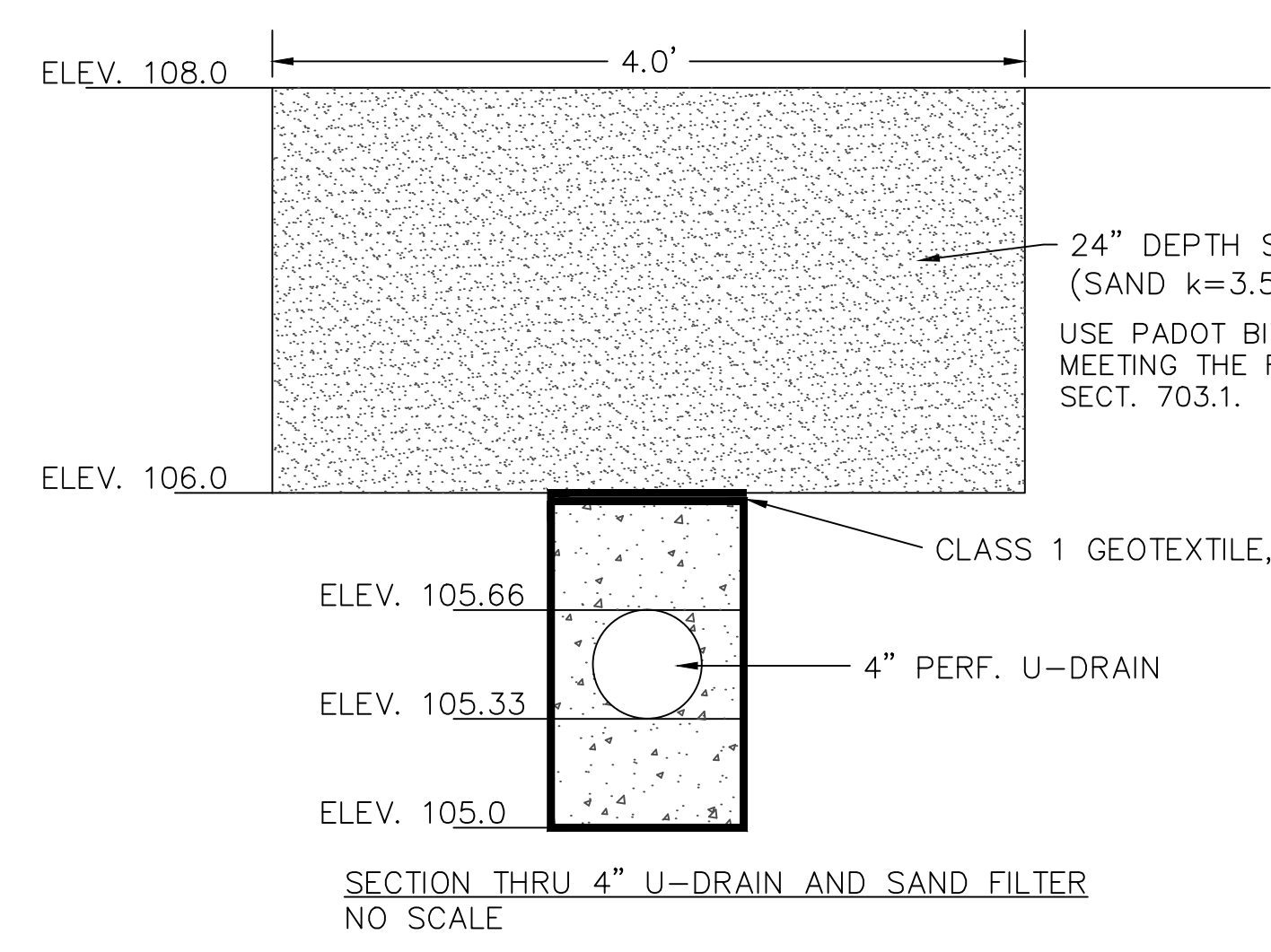
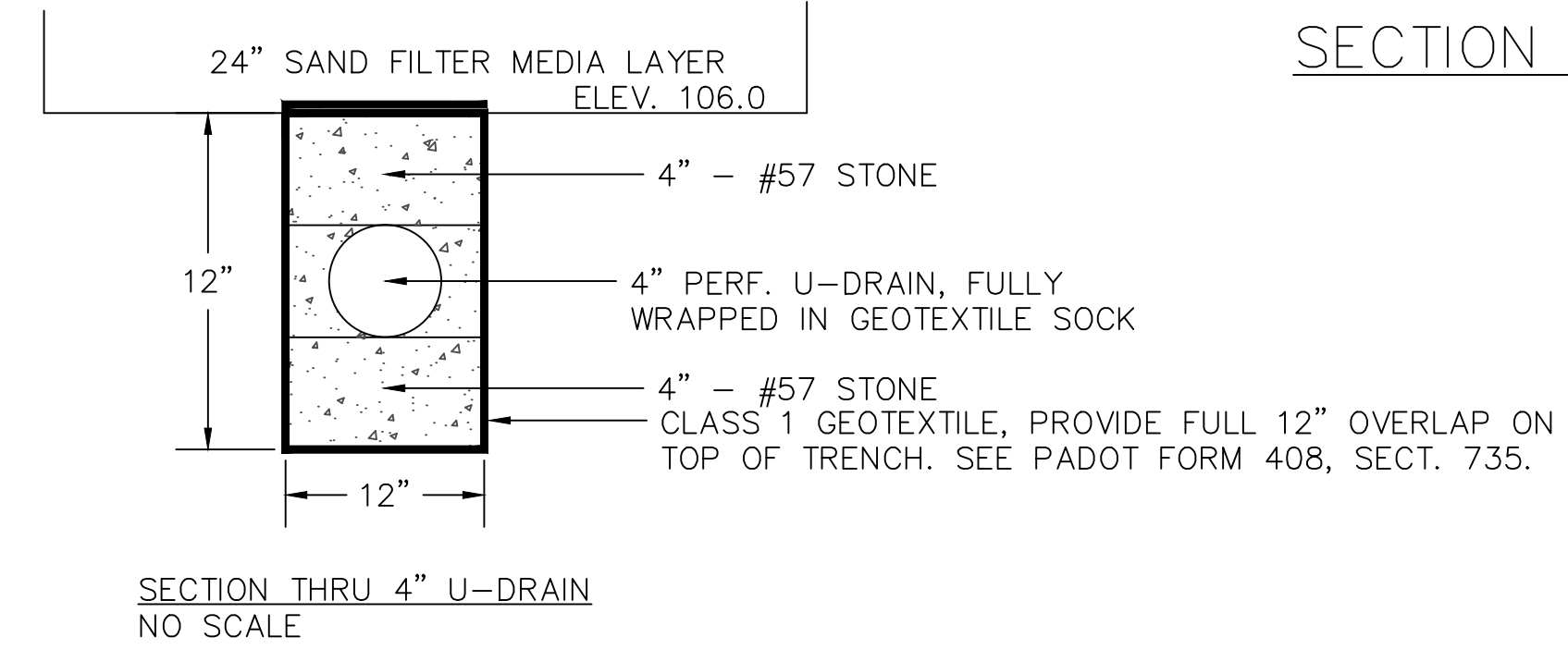
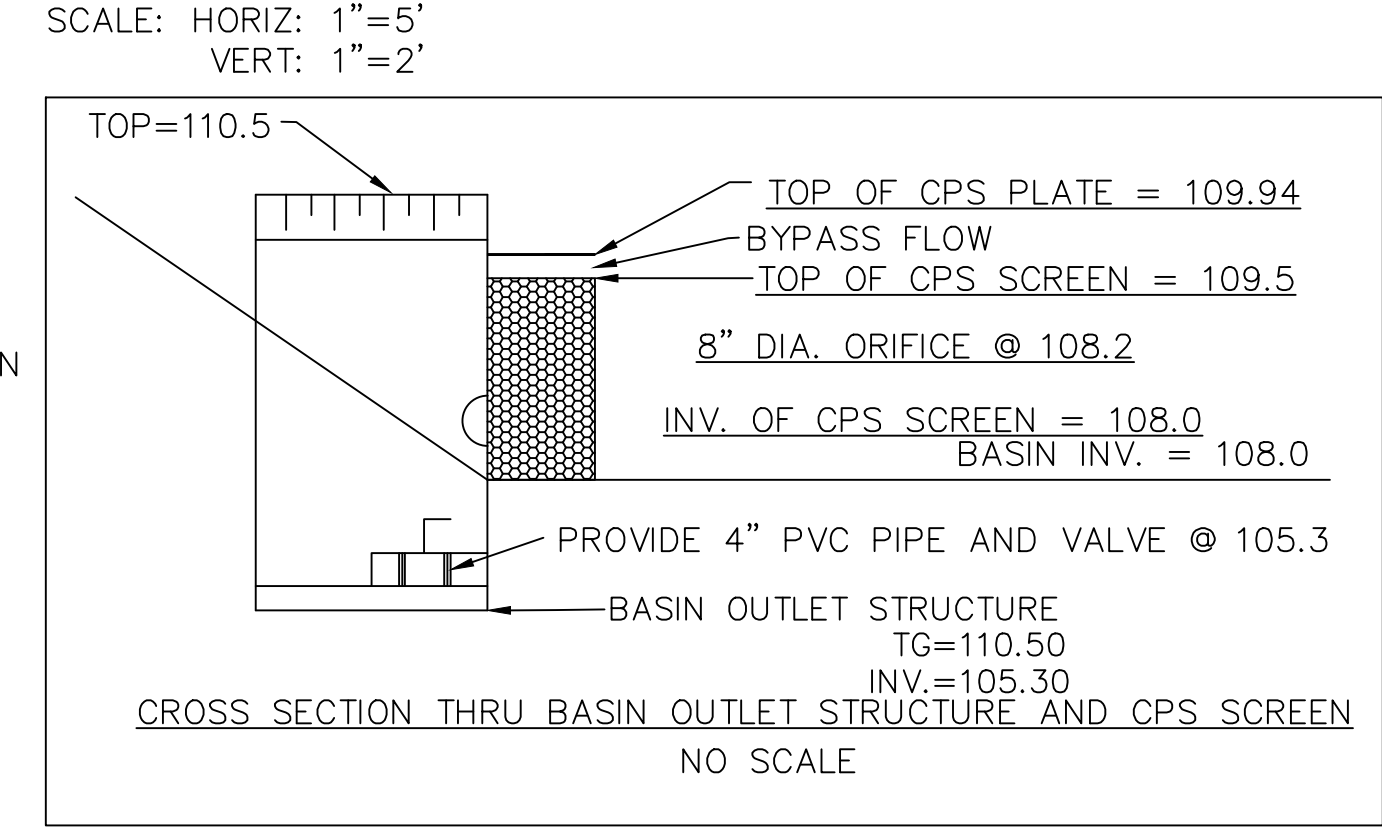

TYP. SECTION THRU SRC DETENTION BASIN
NO SCALE

COMPOST STANDARDS

ORGANIC MATTER CONTENT	80%-100% (DRY WEIGHT BASIS)
ORGANIC	FIBROUS & ELONGATED
pH	5.5-8.0
MOISTURE CONTENT	35%-55%
PARTICLE SIZE	98% PASS THROUGH 1" SCREEN
SOLUBLE SALT CONCENTRATION	5.0 dS/m MAXIMUM

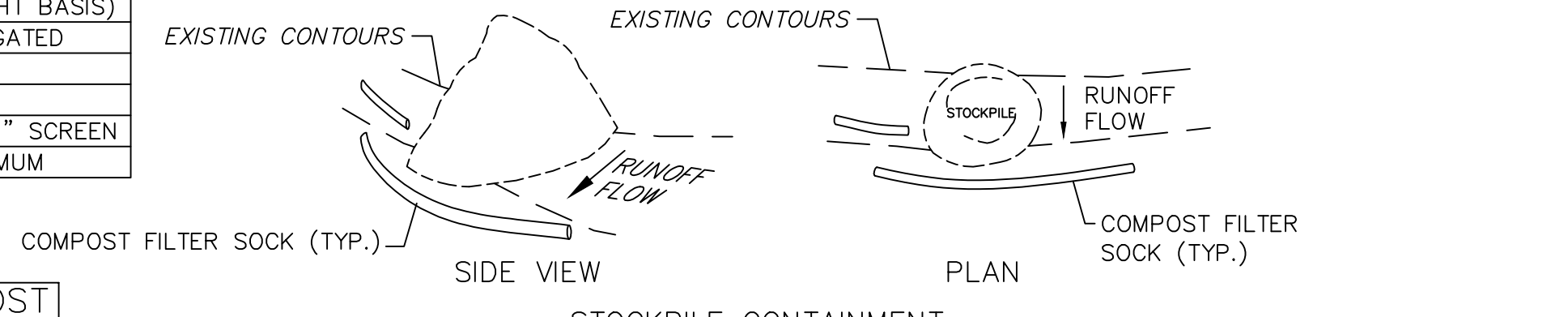
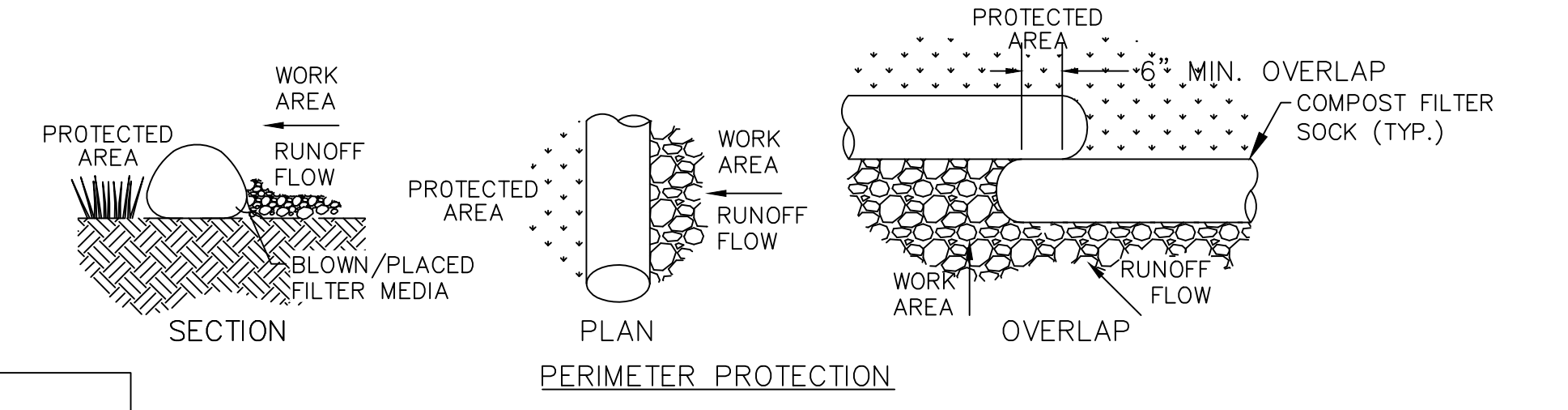

MAXIMUM SLOPE LENGTHS FOR COMPOST FILTER SOCK

% SLOPE	12" DIAMETER	18" DIAMETER	24" DIAMETER	32" DIAMETER
2 (OR LESS)	520	700	1000	1300
5	250	350	500	650
10	150	250	300	400
15	100	190	250	350
20	70	140	200	250
25	50	90	150	180
30	40	70	100	125
35	35	60	90	100
40	30	50	70	90
45	25	40	60	70
50	20	30	50	60

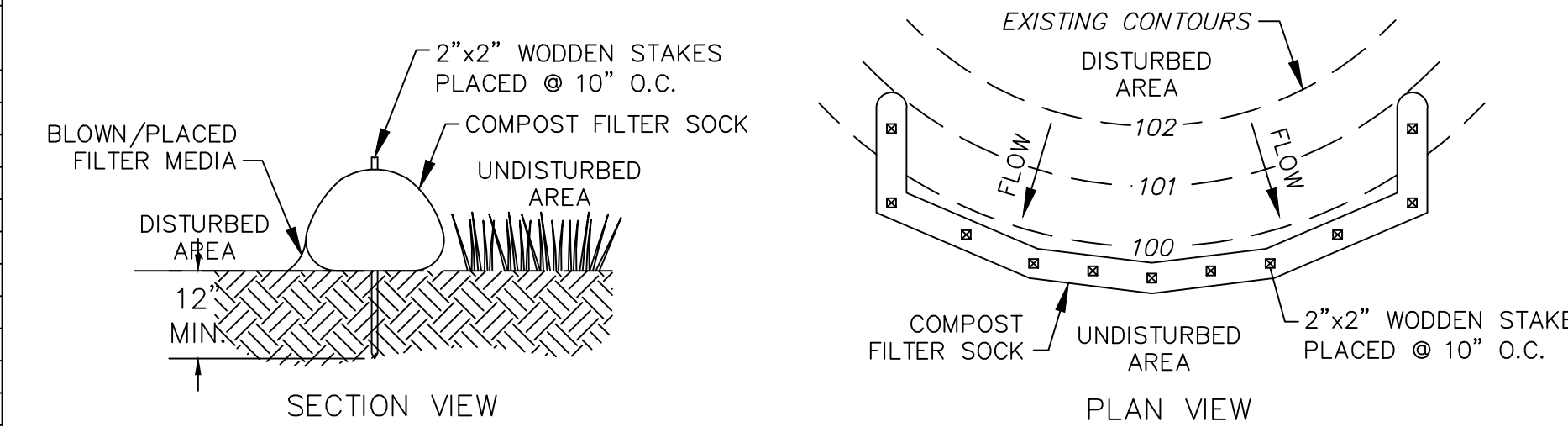

COMPOST FILTER SOCK SHALL BE PLACED AT EXISTING LEVEL GRADE. BOTH ENDS OF THE SOCK SHALL BE EXTENDED AT LEAST 8 FEET UP SLOPE AT 45 DEGREES TO THE MAIN SOCK ALIGNMENT. MAXIMUM SLOPE LENGTH ABOVE SOCK SHALL NOT EXCEED THAT SHOWN ON FIGURE 4.2 IN ATTACHMENT 3.

TRAFFIC SHALL NOT BE PERMITTED TO CROSS FILTER SOCKS.

ACCUMULATED SEDIMENT SHALL BE REMOVED WHEN IT REACHES 1/2 THE ABOVE GROUND HEIGHT OF THE SOCK AND DISPOSED IN THE MANNER DESCRIBED ELSEWHERE IN THE PLAN.

SOCKS SHALL BE INSPECTED WEEKLY AND AFTER EACH RUNOFF EVENT. DAMAGED SOCKS SHALL BE REPAIRED ACCORDING TO MANUFACTURER'S SPECIFICATIONS OR REPLACED WITHIN 24 HOURS OF INSPECTION.

BIODEGRADABLE FILTER SOCK SHALL BE REPLACED AFTER 6 MONTHS; PHOTODEGRADABLE SOCKS AFTER 1 YEAR. POLYPROPYLENE SOCKS SHALL BE REPLACED ACCORDING TO MANUFACTURER'S RECOMMENDATIONS.

UPON STABILIZATION OF THE AREA TRIBUTARY TO THE SOCK, STAKES SHALL BE REMOVED. THE SOCK MAY BE LEFT IN PLACE AND VEGETATED OR REMOVED. IN THE LATTER CASE, THE MESH SHALL BE CUT OPEN AND THE MULCH SPREAD AS A SOIL SUPPLEMENT.

COMPOST FILTER SOCK
NOT TO SCALE

- NOTES:
- ALL EMBANKMENTS SHALL BE PLACED IN A MAXIMUM 8" LIFTS TO A MINIMUM OF 95% OF MAXIMUM DRY DENSITY AS ESTABLISHED BY ASTM D-1557.
 - Maintenance is necessary to ensure proper functionality of the basin and should take place on a quarterly basis. A basin maintenance plan should be developed which includes the following measures:
 - All basin structures expected to receive and/or trap debris and sediment should be inspected for clogging and excessive debris and sediment accumulation at least four times per year, as well as after every storm greater than 1 inch. Structures include basin bottoms, forboys, trash racks, outlets structures, riprap or gabion structures, #57 STONE FILTER and inlets.
 - Sediment removal should be conducted when the basin is completely dry. Sediment should be disposed of properly and once sediment is removed, disturbed areas should be immediately stabilized and revegetated.
 - Mowing and/or trimming of vegetation should be performed as necessary to sustain the system, but all waste and debris should be removed from the basin.
 - Vegetated areas should be inspected annually for erosion.
 - Vegetated areas should be inspected annually for unwanted growth of exotic/invasive species.
 - Vegetative cover should be maintained at a minimum of 95 percent. If vegetative cover has been reduced by 10%, vegetation should be reestablished.
 - Catch Basins and Inlets (upgradient of basin) should be inspected and cleaned at least two times per year and after major runoff events.
 - Vehicles should not be parked or driven on a Basin, and care should be taken to avoid excessive compaction by mowers.
 - Inspect the basin after runoff events and make sure that runoff drains down within 72 hours. Mosquito's should not be a problem if the water drains in 72 hours. Mosquitoes require a considerably long breeding period with relatively static water levels.
 - Also inspect for accumulation of sediment, damage to outlet control structures, erosion control measures, signs of water contamination/spills, and slope stability in the berms. Mow only as appropriate for vegetative cover species.
 - Remove accumulated sediment from basin as required. Properly dispose of sediment.
 - Inspect "CPS Screen" to insure proper functioning of basin outlet works. Remove debris and cleanout screen after all storm events over 1" and at least twice per year.
 - If #57 stone filter becomes blocked or clogged with material, remove portions of the stone and replace with new #57 stone. Dispose of material in a proper manner.

6 OF 9	<p>TETRA TECH www.tetrattech.com 1134 TWIN STACKS DRIVE DALLAS, PA 18612 T: (570) 674-8648 F: (570) 674-8651</p>	MARK	DATE	DESCRIPTION	BY	<p>PPP - TWIN OAKS PUMP STATION UPPER CHICHESTER TOWNSHIP, DELAWARE COUNTY</p> <p>E&S PLAN - CONSTRUCTION DETAILS</p>	<p>DATE:03/11/16 PROJECT NO.:IC-PB-00136 DRAWN BY:GZ CHECKED BY:TC SCALE:AS NOTED FILE:CONSTDET NAME:CONSTDET 5 COPYRIGHT TETRA TECH INC.</p>
		1	5/13/16	REVISED PER DEP COMMENT LETTER (3/28/16)	GZ		
		2	10/10/16	REVISED PER DEP COMMENT LETTER (9/6/16)	GZ		
		3	2/4/17	REVISED PER DEP COMMENT LETTER (1/31/17)	TC		

STANDARD EROSION AND SEDIMENT CONTROL PLAN NOTES

- ALL EARTH DISTURBANCES, INCLUDING CLEARING AND GRUBBING AS WELL AS CUTS AND FILLS SHALL BE DONE IN ACCORDANCE WITH THE APPROVED E&S PLAN. A COPY OF THE APPROVED DRAWINGS (STAMPED, SIGNED AND DATED BY THE REVIEWING AGENCY) MUST BE AVAILABLE AT THE PROJECT SITE AT ALL TIMES. THE REVIEWING AGENCY SHALL BE NOTIFIED OF ANY CHANGES TO THE APPROVED PLAN PRIOR TO IMPLEMENTATION OF THOSE CHANGES. THE REVIEWING AGENCY MAY REQUIRE A WRITTEN SUBMITTAL OF THOSE CHANGES FOR REVIEW AND APPROVAL AT ITS DISCRETION.
- AT LEAST 7 DAYS PRIOR TO STARTING ANY EARTH DISTURBANCE ACTIVITIES, INCLUDING CLEARING AND GRUBBING, THE OWNER AND/OR OPERATOR SHALL INVITE ALL CONTRACTORS, THE LANDOWNER, APPROPRIATE MUNICIPAL OFFICIALS, THE E&S PLAN PREPARER, AND A REPRESENTATIVE FROM THE LOCAL PADEP OR CONSERVATION DISTRICT TO AN ON-SITE PRECONSTRUCTION MEETING.
- AT LEAST 3 DAYS BEFORE STARTING ANY EARTH DISTURBANCE ACTIVITIES, ALL CONTRACTORS INVOLVED IN THOSE ACTIVITIES SHALL NOTIFY THE PENNSYLVANIA ONE CALL SYSTEM AT 1-800-242-1776 FOR BURIED UTILITIES LOCATIONS.
- ALL EARTH DISTURBANCE ACTIVITIES SHALL PROCEED IN ACCORDANCE WITH THE SEQUENCE PROVIDED ON THE PLAN DRAWINGS. DEVIATION FROM THAT SEQUENCE MUST BE APPROVED IN WRITING FROM THE LOCAL CONSERVATION DISTRICT OR BY THE DEPARTMENT PRIOR TO IMPLEMENTATION
- CLEARING, GRUBBING, AND TOPSOIL STRIPPED SHALL BE LIMITED TO THOSE AREAS DESCRIBED IN EACH STAGE OF THE CONSTRUCTION SEQUENCE. GENERAL SITE CLEARING, GRUBBING AND TOPSOIL STRIPPING MAY NOT COMMENCE IN ANY STAGE OR PHASE OF THE PROJECT UNTIL THE E&S BMPs SPECIFIED BY THE BMP SEQUENCE FOR THAT STAGE OR PHASE HAVE BEEN INSTALLED AND ARE FUNCTIONING AS DESCRIBED IN THE E&S PLAN.
- AT NO TIME SHALL CONSTRUCTION VEHICLES BE ALLOWED TO ENTER AREAS OUTSIDE THE LIMIT OF DISTURBANCE BOUNDARIES SHOWN ON THE PLAN MAPS. THESE AREAS MUST BE CLEARLY MARKED AND FENCED OFF BEFORE CLEARING AND GRUBBING OPERATIONS BEGIN.
- TOPSOIL REQUIRED FOR THE ESTABLISHMENT OF VEGETATION SHALL BE STOCKPILED AT THE LOCATION(S) SHOWN ON THE PLAN MAP(S) IN THE AMOUNT NECESSARY TO COMPLETE THE FINISH GRADING OF ALL EXPOSED AREAS THAT ARE TO BE STABILIZED BY VEGETATION. EACH STOCKPILE SHALL BE PROTECTED IN THE MANNER SHOWN ON THE PLAN DRAWINGS. STOCKPILE HEIGHTS SHALL NOT EXCEED 35 FEET. STOCKPILE SLOPES SHALL BE 2H:1V OR FLATTER.
- IMMEDIATELY UPON DISCOVERING UNFORSEEN CIRCUMSTANCES POSING THE POTENTIAL FOR ACCELERATED EROSION AND/OR SEDIMENT POLLUTION, THE OPERATOR SHALL IMPLEMENT APPROPRIATE BEST MANAGEMENT PRACTICES TO MINIMIZE THE POTENTIAL FOR EROSION AND SEDIMENT POLLUTION AND NOTIFY THE LOCAL CONSERVATION DISTRICT AND/OR THE REGIONAL OFFICE OF THE DEPARTMENT.
- ALL PUMPING OF WATER FROM ANY WORK AREA SHALL BE DONE ACCORDING TO THE PROCEDURE DESCRIBED IN THIS PLAN, OVER UNDISTURBED VEGETATED AREAS.
- UNTIL THE SITE IS STABILIZED, ALL EROSION AND SEDIMENT BMPs SHALL BE MAINTAINED PROPERLY. MAINTENANCE SHALL INCLUDE INSPECTIONS OF ALL EROSION AND SEDIMENT BMPs AFTER EACH RUNOFF EVENT AND ON A WEEKLY BASIS. ALL PREVENTATIVE AND REMEDIAL MAINTENANCE WORK, INCLUDING CLEAN OUT, REPAIR, REPLACEMENT, REGRADING, RESEEDING, REMULCHING AND RENETTING MUST BE PERFORMED IMMEDIATELY. IF THE E&S BMPs FAIL TO PERFORM AS EXPECTED, REPLACEMENT BMPs, OR MODIFICATIONS OF THOSE INSTALLED WILL BE REQUIRED.
- A LOG SHOWING DATES THAT E&S BMPs WERE INSPECTED AS WELL AS ANY DEFICIENCIES FOUND AND THE DATE THEY WERE CORRECTED SHALL BE MAINTAINED ON THE SITE AND BE MADE AVAILABLE TO REGULATORY AGENCY OFFICIALS AT THE TIME OF INSPECTION.
- SEDIMENT TRACKED ONTO ANY PUBLIC ROADWAY OR SIDEWALK SHALL BE RETURNED TO THE CONSTRUCTION SITE BY THE END OF EACH WORK DAY AND DISPOSED IN THE MANNER DESCRIBED IN THIS PLAN. IN NO CASE SHALL THE SEDIMENT BE WASHED, SHOVELED, OR SWEEPED INTO ANY ROADSIDE DITCH, STORM SEWER, OR SURFACE WATER.
- ALL SEDIMENT REMOVED FROM BMPs SHALL BE PLACED WITHIN THE RIGHT-OF-WAY EXCEPT IN WETLAND AREAS OR AS OTHERWISE DESCRIBED IN THE PLAN DRAWINGS.
- AREAS WHICH ARE TO BE TOPSOILED SHALL BE SCARIFIED TO A MINIMUM DEPTH OF 3 TO 5 INCHES – 6 TO 12 INCHES ON COMPACTED SOILS – PRIOR TO PLACEMENT OF TOPSOIL. AREAS TO BE VEGETATED SHALL HAVE A MINIMUM 4 INCHES OF TOPSOIL IN PLACE PRIOR TO SEEDING AND MULCHING. FILL OUTSLOPES SHALL HAVE A MINIMUM OF 2 INCHES OF TOPSOIL.
- E&S BMPs SHALL REMAIN FUNCTIONAL AS SUCH UNTIL ALL AREAS TRIBUTARY TO THEM ARE PERMANENTLY STABILIZED OR UNTIL THEY ARE REPLACED BY ANOTHER BMP APPROVED BY THE LOCAL CONSERVATION DISTRICT OR THE DEPARTMENT.
- UPON COMPLETION OF ALL EARTH DISTURBANCE ACTIVITIES AND PERMANENT STABILIZATION OF ALL DISTURBED AREAS, THE OWNER AND/OR OPERATOR SHALL CONTACT THE PA DEP OR THE LOCAL CONSERVATION DISTRICT FOR AN INSPECTION PRIOR TO REMOVAL/CONVERSION OF THE E&S BMPs.
- UPON COMPLETION OF ALL EARTH DISTURBANCE ACTIVITIES AND PERMANENT STABILIZATION OF ALL DISTURBED AREAS, THE OWNER AND/OR OPERATOR SHALL CONTACT THE PA DEP OR LOCAL CONSERVATION DISTRICT TO SCHEDULE A FINAL INSPECTION.
- UNDERGROUND UTILITIES CUTTING THROUGH ANY ACTIVE CHANNEL SHALL BE IMMEDIATELY BACKFILLED AND THE CHANNEL RESTORED TO ITS ORIGINAL CROSS-SECTION AND PROTECTIVE LINING. ANY BASE FLOW WITHIN THE CHANNEL SHALL BE CONVEYED PAST THE WORK AREA IN THE MANNER DESCRIBED IN THIS PLAN UNTIL SUCH RESTORATION IS COMPLETE.
- AN AREA SHALL BE CONSIDERED TO HAVE ACHIEVED FINAL STABILIZATION WHEN IT HAS A MINIMUM UNIFORM 70% PERENNIAL VEGETATIVE COVER OR OTHER PERMANENT NON-VEGETATIVE COVER WITH A DENSITY SUFFICIENT TO RESIST ACCELERATED SURFACE EROSION AND SUBSURFACE CHARACTERISTICS SUFFICIENT TO RESIST SLIDING AND OTHER MOVEMENTS.
- IF EARTH DISTURBANCE ACTIVITIES ARE TO CEASE FOR MORE THAN 4 DAYS, THE OPERATOR SHALL STABILIZE ANY AREAS DISTURBED BY THE ACTIVITIES. DURING NON-GERMINATING PERIODS, MULCH MUST BE APPLIED AT THE SPECIFIED RATES. DISTURBED AREAS WHICH ARE NOT AT FINISHED GRADE AND WHICH WILL BE REDISTURBED WITHIN 1 YEAR MUST BE STABILIZED IN ACCORDANCE WITH THE TEMPORARY VEGETATIVE STABILIZATION SPECIFICATIONS. DISTURBED AREAS WHICH ARE AT FINISHED GRADE OR WHICH WILL NOT BE REDISTURBED WITHIN 1 YEAR MUST BE STABILIZED IN ACCORDANCE WITH THE PERMANENT VEGETATIVE STABILIZATION SPECIFICATIONS. ACCESS AREAS THAT CONTINUE TO BE DISTURBED WILL BE STABILIZED ONCE ACTIVITY IS COMPLETE.
- AT STREAM CROSSINGS, 50' BUFFER AREAS SHOULD BE MAINTAINED. ON BUFFERS, CLEARING, SOD DISTURBANCES, EXCAVATION, AND EQUIPMENT TRAFFIC SHOULD BE MINIMIZED. ACTIVITIES SUCH AS STACKING LOGS, BURNING CLEARED BRUSH, DISCHARGING RAINWATER FROM TRENCHES, WELDING PIPE SECTIONS, REFUELING AND MAINTAINING EQUIPMENT SHOULD BE ACCOMPLISHED OUTSIDE OF BUFFERS.
- MULCH WITH NETTING OR EROSION CONTROL BLANKETS MUST BE INSTALLED ON ALL SLOPES 3:1 AND STEEPER AND WITHIN 100' OF SPECIAL PROTECTION WATERS OR 50' OF SURFACE WATERS.
- THE OPERATOR SHALL REMOVE FROM THE SITE, RECYCLE, OR DISPOSE OF ALL BUILDING MATERIALS AND WASTES IN ACCORDANCE WITH THE DEPARTMENT'S SOLID WASTE MANAGEMENT REGULATIONS AT 25 PA. CODE 260.1 ET SEQ., AND 287.1 ET SEQ. THE CONTRACTOR SHALL NOT ILLEGALLY BURY, DUMP, OR DISCHARGE ANY BUILDING MATERIAL OR WASTES AT THE SITE.

REVEGETATION

A. TEMPORARY GRASS COVER SHALL BE ESTABLISHED IN THE FOLLOWING AREAS:

- WHERE VEGETATIVE FILTERS MUST BE ESTABLISHED BELOW FILTER BAGS, A MINIMUM DISTANCE OF 10 FT SHALL BE SEEDED DOWNSLOPE OF THE TRAP OUTLET. TEMPORARY COVER – SEED MIXTURE FOR TEMPORARY COVER SHALL CONSIST OF 100% ANNUAL RYEGRASS. SEED SHALL BE APPLIED AT THE RATE OF 40 LB/ACRE OR AS RECOMMENDED BY A LOCAL RECOGNIZED SEED SUPPLIER APPROVED BY THE OWNER'S REPRESENTATIVE. PRIOR TO SEEDING, APPLY 1 TON OF AGRICULTURAL GRADE LIMESTONE PER ACRE PLUS 10-10-10 FERTILIZER AT THE RATE OF 500 LB. PER ACRE AND WORK INTO SOIL.

B. PERMANENT COVER – SEE LINE LIST FOR LANDOWNER REQUIREMENTS. IN ABSENCE OF A SPECIFIED MIXTURE IT SHALL BE:

PERMANENT SEED MIXTURE							
SCIENTIFIC NAME	COMMON NAME	REQUIRED VARIETIES	MINIMUM % PURITY	MINIMUM % GERMINATION	SEEDING RATE (LBS/1000 SF)	SEEDING RATE (LBS/ACRE)	
LOLIUM PERENNE	PERENNIAL RYEGRASS	A MIXTURE OF AT LEAST 2 FINE LEAF, TURF TYPE VARIETIES ADAPTED TO LOCAL CONDITIONS	98	90	0.8	35	
FESTUCA RUBRA	RED FESCUE	"PENNLAWN"	98	85	0.8	35	
LOTUS COMICULATUS	BIRDSFOOT TREFOIL (BIRDSFOOT DEEVETCH)	"VIKING", "EMPIRE", "LEO" OR "NORCEN" (PLUS 5X LEGUME INOCULANT RATE)	98	80	0.7	30	
PLUS, DEPENDING ON THE SEASON AND SEED AVAILABILITY, ALSO ADD ONE OF THE FOLLOWING "NURSE CROP" SPECIES:							
AVENA SATIVA	OATS – APRIL 1 TO SEPTEMBER 1	COMMON SEED	98	85	0.7	32	
SECALE CEREALE	WINTER RYE – APRIL 1 TO OCTOBER 1	"AROOSTOOK" OR COMMON SEED	98	85	1.3	56	
SECALE CEREALE	WINTER RYE – OCTOBER 1 TO APRIL 1	"AROOSTOOK" OR COMMON SEED	98	85	2.6	112	
NOTE: STRAW MULCH SHALL BE APPLIED AT THE RATE OF THREE TONS PER ACRE. CHEMICALLY TREATED OR SALTED STRAW IS NOT ACCEPTABLE AS MULCH.					TOTAL	3 TO 5	132 TO 212

TEMPORARY EROSION AND SEDIMENT CONTROLS INSPECTION AND MAINTENANCE SCHEDULE		
BMP	INSPECTION FREQUENCY	MAINTENANCE TO BE PERFORMED
COMPOST FILTER SOCK	WEEKLY AND AFTER RUNOFF EVENTS	MAINTENANCE SHALL BE PERFORMED AS NEEDED, SEDIMENT SHALL BE REMOVED ONCE IT HAS ACCUMULATED TO ONE THIRD THE ORIGINAL HEIGHT OF THE BARRIER. COMPOST FILTER SOCK SHALL BE REPLACED WHENEVER IT HAS DETERIORATED TO SUCH AN EXTENT THAT THE EFFECTIVENESS OF COMPOST FILTER SOCK IS REDUCED. COMPOST FILTER SOCKS SHALL REMAIN IN PLACE UNTIL DISTURBED AREAS HAVE BEEN PERMANENTLY STABILIZED. ALL SEDIMENT ACCUMULATION AT THE COMPOST FILTER SOCK SHALL BE REMOVED AND PROPERLY DISPOSED OF BEFORE THE COMPOST FILTER SOCK IS REMOVED.
ROCK CONSTRUCTION ENTRANCE	DAILY	CONTRACTOR SHALL MAINTAIN/REPLACE MATERIAL AS NEEDED THROUGHOUT CONSTRUCTION TO MAINTAIN SPECIFIED MINIMUM THICKNESS DURING USE OF ACCESS ROAD. A STOCKPILE OF ROCK WILL BE MAINTAINED ON SITE FOR THIS PURPOSE
MULCH STABILIZATION	WEEKLY AND AFTER RUNOFF EVENTS	REPLACE MULCH AS REQUIRED. RESTORE SEEDING IN AFFECTED AREA IF NECESSARY.
TIMBER MAT	WEEKLY AND AFTER RUNOFF EVENTS	INSPECT THE TIMBER MAT FOR EROSION AND MAKE ANY NECESSARY REPAIRS.
WATERBARS	WEEKLY AND AFTER RUNOFF EVENTS	WATERBARS SHALL BE INSPECTED WEEKLY (DAILY ON ACTIVE ROADS) AND AFTER EACH RUNOFF EVENT. DAMAGED OR ERODED WATERBARS SHALL BE RESTORED TO ORIGINAL DIMENSIONS WITHIN 24 HOURS OF INSPECTION.
PUMPED WATER FILTER BAGS	DAILY	FILTER BAGS SHALL BE REPLACED WHEN THEY BECOME 1/2 FULL OF SEDIMENT. IF ANY PROBLEM IS DETECTED, PUMPING SHALL CEASE IMMEDIATELY AND NOT RESUME UNTIL THE PROBLEM IS CORRECTED.
TEMPORARY #57 STONE FILTER	WEEKLY AND AFTER RUNOFF EVENTS	REMOVE SEDIMENT OR ANY MATERIAL BLOCKING THE FACE OF THE FILTER. IF #57 STONE BECOMES BLOCKED, REMOVE A PORTION OF THE STONE AND REPLACE WITH NEW #57 STONE.

CONSTRUCTION SEQUENCE

A GENERALIZED CONSTRUCTION SEQUENCE IS PROVIDED BELOW. THE CONSTRUCTION SEQUENCE IS INTENDED TO PROVIDE A GENERAL COURSE OF ACTION IN ORDER TO CONFORM TO THE APPLICABLE REGULATORY AGENCY REQUIREMENTS FOR TEMPORARY AND PERMANENT SOIL E&SCS. NECESSARY COMPONENTS FOR PROPER AND COMPLETE EXECUTION OF WORK PERTAINING TO THIS PLAN, WHETHER SPECIFICALLY MENTIONED OR NOT, ARE TO BE PERFORMED BY THE CONTRACTOR. IT IS NOT INTENDED THAT THE DRAWINGS AND THIS REPORT SHOW DETAILED INFORMATION ON METHODS AND MATERIALS. THE CONTRACTOR SHALL COMPLY WITH ALL REQUIREMENTS LISTED IN THIS SECTION, AND SHALL COMPLY WITH THE PADEP E&S POLLUTION CONTROL MANUAL, 2012. THE CONTRACTOR MAY BE REQUIRED TO ALTER CONTROLS BASED ON EFFECTIVENESS OF CONTROLS OR DIFFERING CONDITIONS ENCOUNTERED IN THE FIELD.

- ALL EARTH DISTURBANCE ACTIVITIES SHALL PROCEED IN ACCORDANCE WITH THE FOLLOWING SEQUENCE. EACH STAGE SHALL BE COMPLETED BEFORE ANY FOLLOWING STAGE IS INITIATED. CLEARING AND GRUBBING SHALL BE LIMITED ONLY TO THOSE AREAS DESCRIBED IN EACH STAGE.
- Field mark Limit of Disturbance, Waters of the Commonwealth, which include wetlands, streams, spring seeps and all areas shown as Protected Areas on the Existing Conditions Plan. Field mark compost filter sock placement.
- Install the stabilized construction entrance.
- Install compost filter sock as indicated on plan.
- Complete clearing and grubbing of additional pad area and SRC detention basin.
- Stockpile grubbing in soil stockpile areas. Any materials removed from the site, and not taken to a permitted landfill, will require a separate Erosion Control Plan submittal.
- Complete cut and fill of pad area and basin. Stabilize all slopes immediately. As grass areas reach final grade, seed and mulch, install S-150 erosion control blankets on all slopes steeper than 3H:1V.
- Place stone on pad.
- After pad area work is complete and stabilized, complete remaining excavation for slow release basin. PROFESSIONAL OVERSIGHT REQUIRED DURING SLOW RELEASE BASIN CONSTRUCTION, BASIN OUTLET PIPE, ANTI-SEEP COLLAR AND RIPRAP APRON INSTALLATION. OVERSIGHT REQUIRED DURING SAND FILTER AND 4" U-DRAIN INSTALLATION. Install temporary #57 stone filter in front of outlet structure. Stabilize all disturbed areas immediately.
- Complete final seeding and mulching of remaining disturbed areas.
- An area shall be considered to have achieved final stabilization when it has a MINIMUM uniform 70% perennial vegetative cover or other permanent non-vegetative cover with a density sufficient to resist accelerated surface erosion and subsurface characteristics sufficient to resist sliding and other movement. After the site reaches 70% stabilization, remove and dispose of any remaining compost filter socks in a legal manner.
- All controls must be installed prior to beginning any grading or excavation work on the project. The Permittee/Co-Permittee (Sunoco) will be responsible to insure that the controls are installed and functioning as per plan.

TEMPORARY CONTROLS

- Place compost filter sock as indicated.
- Material imported to the site will be stockpiled in designated areas and surrounded by 12" high compost filter sock.
- Sediment removed from control facilities will be stockpiled in designated areas, surrounded by compost filter sock and temporarily seeded. Sediment will be reused for future landscaping.
- Areas left exposed and not subject to construction traffic shall receive a temporary seeding.
- A stabilized construction entrance will be placed as shown and maintained until the project is complete.
- Place stone subbase over pad and driveway as soon as possible after grading is completed.
- The total length of excavated trench open at any one time should not be greater than the total length of pipeline/utility line than can be placed in the trench and back-filled in one working day. No more than 50 ft. of open trench should exist when pipeline/utility line installation ceases at the end of the workday. Complete soil supplements, seeding and mulching within 7 days after the pipeline/utility line is installed.
- North American Green S-150 erosion control blankets will be placed ON ALL DISTURBED AREA SLOPES AT 3H:1V OR STEEPER.
- Place a #57 stone filter in front of basin outlet structure. Remove after the site reaches 70% stabilization.

PERMANENT CONTROLS

- Permanent seeding and mulching specifications are described on plans.
- Complete seeding and mulching as soon as areas are at grade.
- The emergency spillway will be lined with R-4 riprap.

INSPECTION AND MAINTENANCE OF CONTROL FACILITIES

- ALL BMPs are to be inspected AT LEAST ONCE WEEKLY AND AFTER ALL RUNOFF EVENTS.
- Retained sediment will be utilized for landscaping.
- All control facilities will remain in place until final stabilization is complete. Maintenance must include inspections of all erosion and sedimentation control facilities after each runoff event and on a weekly basis. All preventative and remedial work, including cleanout, repair, replacement, regrading, reseeding, remulching and renetting, must be performed immediately. Any sediment removed from BMP's shall be disposed of in landscaped areas outside of steep slopes, wetlands, floodplains or drainage swales and immediately stabilized or placed in topsoil stockpiles.
- The Permittee/Co-Permittee will be responsible for inspection and maintenance of facilities during construction. The Permittee (Sunoco Logistics Partners, LP) will be responsible for permanent inspection and maintenance after stabilization is complete. All controls must be installed prior to beginning any grading or excavation work on the project. The Permittee will be responsible to insure that the controls are installed as per plan. BMPs WILL BE OWNED AND MAINTAINED BY THE PERMITTEE. Maintenance of BMP's will include the following:
 - Inspect BMP's at least once per month or after any rainfall event over ONE INCH. Remove accumulated sediment and/or garbage that remain in the inlets or basin outlet structures.
 - Any accumulated sediment within the detention basin will be removed and stockpiled in designated areas, or removed from the site and deposited in an approved landfill or dump area.
 - Inspect BMP's after any rainfall event over ONE INCH. Immediately repair and stabilize any washouts within swales or slope areas. Any gullies that form on surfaces must be immediately repaired with topsoil material, soil supplements, seed and mulch. Do not direct runoff to swales or BMP's until all upstream areas are stable and free from sediment-laden runoff.
 - The permittee and co-permittee(s) must ensure that visual site inspections are conducted weekly, and within 24 hours after each measurable rainfall event throughout the duration of construction. The visual site inspections and reports shall be completed in a format provided by the Department, and conducted by qualified personnel, trained and experienced in erosion and sediment control, to ascertain that E & S BMP's and PCSM BMP's are properly constructed and maintained to effectively minimize pollution to the waters of the Commonwealth.
 - Project construction wastes and demolition waste shall be disposed of in a legal manner. Individuals responsible for earth disturbance activities must ensure that proper mechanisms are in place to control waste materials. Building and demolition waste (ie. drywall, wood) will be transported to landfills. Construction wastes include, but are not limited to, excess soil material, building materials, concrete wash water, sanitary wastes, etc., that could adversely impact water quality. Any soil or rock not needed for construction purposes will be stockpiled in designated on-site areas and immediately seeded and mulched. Wherever possible, recycling of excess materials is preferred, rather than disposal. Any soil or rock waste or soil borrow areas created off-site will require a separate Erosion Control Plan submission to the appropriate Conservation District.
 - Until the site is stabilized, all erosion and sediment control BMP's must be maintained properly. Maintenance must include inspections of all erosion and sediment control BMP's after each runoff event and on a weekly basis. All preventative and remedial maintenance work, including clean out, repair, replacement, regrading, reseeding, remulching and renetting must be performed immediately. If erosion and sediment control BMP's fail to perform as expected, replacement BMP's, or modifications of those installed will be required.
 - All excavated material will remain on site, to be used for embankment areas. There will be no removal of soil to other off-site areas unless Form FP-001 is completed for each waste area.

ENVIRONMENTAL DUE DILIGENCE: DEFINITION

Investigative techniques, including but not limited to, visual property inspections, electronic data base searches, review of property ownership, review of property use history, Sanborn Maps, environmental questionnaires, transaction screens, analytical testing, environmental assessments or audits. Analytical testing is not a required part of due diligence unless visual inspection and/or review of the past land use of the property indicates that the fill may have been subjected to a spill or release of regulated substance. If the fill may have been affected by a spill or release of a regulated substance, it must be tested to determine if it qualifies as a clean fill. Testing should be performed in accordance with Appendix A of the Department's policy "Management of Fill". Fill Material that does not qualify as clean fill is regulated fill. Regulated fill is waste and must be managed in accordance with the Department's municipal or residual waste regulations based on 25 Pa. Code Chapters 287 Residual Waste Management or 217 Municipal Waste Management, whichever is applicable.

DEFINITION: CLEAN FILL IS DESCRIBED AS: Uncontaminated, non-water soluble, non-decomposable, inert, solid material, used asphalt, and brick, block or concrete from construction or demolition activities that is separate from other waste and is recognizable as such. The term does not include materials placed in or on the waters of the Commonwealth unless otherwise authorized. (The term "used asphalt" does not include milled asphalt or asphalt that has been processed for re-use.)

IMPACT TO DOWNSTREAM WATERCOURSES

The impact to downstream watercourses is minimal. All runoff from the project is directed to an existing unnamed tributary to Baldwin Run, within the Sunoco parcel.

 <p>TETRA TECH</p> <p>www.tetrattech.com</p> <p>1134 TWIN STACKS DRIVE DALLAS, PA 18612 T: (570) 674-8648 F: (570) 674-8651</p>	7	<table border="1"> <thead> <tr> <th>MARK</th> <th>DATE</th> <th>DESCRIPTION</th> <th>BY</th> </tr> </thead> <tbody> <tr> <td>1</td> <td>5/13/16</td> <td>REVISED PER DEP COMMENT LETTER (3/28/16)</td> <td>GZ</td> </tr> <tr> <td>2</td> <td>10/10/16</td> <td>REVISED PER DEP COMMENT LETTER (9/6/16)</td> <td>GZ</td> </tr> <tr> <td>3</td> <td>2/4/17</td> <td>REVISED PER DEP COMMENT LETTER (1/31/17)</td> <td>TC</td> </tr> <tr> <td></td> <td></td> <td></td> <td></td> </tr> <tr> <td></td> <td></td> <td></td> <td></td> </tr> <tr> <td></td> <td></td> <td></td> <td></td> </tr> <tr> <td></td> <td></td> <td></td> <td></td> </tr> </tbody> </table>	MARK	DATE	DESCRIPTION	BY	1	5/13/16	REVISED PER DEP COMMENT LETTER (3/28/16)	GZ	2	10/10/16	REVISED PER DEP COMMENT LETTER (9/6/16)	GZ	3	2/4/17	REVISED PER DEP COMMENT LETTER (1/31/17)	TC																	OF	<p>DATE: 03/11/16</p> <p>PROJECT NO.: IC-PB-00136</p> <p>DRAWN BY: GZ</p> <p>CHECKED BY: TC</p> <p>SCALE: AS NOTED</p> <p>FILE: CONSTDET</p> <p>NAME: CONSTDET B</p> <p>COPYRIGHT TETRA TECH INC.</p>
	MARK		DATE	DESCRIPTION	BY																															
	1		5/13/16	REVISED PER DEP COMMENT LETTER (3/28/16)	GZ																															
	2		10/10/16	REVISED PER DEP COMMENT LETTER (9/6/16)	GZ																															
3	2/4/17	REVISED PER DEP COMMENT LETTER (1/31/17)	TC																																	
9																																				
<p>PPP – TWIN OAKS PUMP STATION</p> <p>UPPER CHICHESTER TOWNSHIP, DELAWARE COUNTY</p> <p>E&S PLAN – CONSTRUCTION DETAILS</p>																																				

