

Department of the Army  
Pamphlet 385-64

Safety

# **Ammunition and Explosives Safety Standards**

Headquarters  
Department of the Army  
Washington, DC  
24 May 2011

**UNCLASSIFIED**

# ***SUMMARY of CHANGE***

DA PAM 385-64

Ammunition and Explosives Safety Standards

This major revision, dated 24 May 2011--

- o Updates and prescribes Army policy on ammunition and explosive safety standards (throughout).
- o Makes administrative changes (throughout).

## Safety

# Ammunition and Explosives Safety Standards

---

By Order of the Secretary of the Army:

MARTIN E. DEMPSEY  
General, United States Army  
Chief of Staff

Official:

  
JOYCE E. MORROW  
Administrative Assistant to the  
Secretary of the Army

**History.** This publication is a major revision.

**Summary.** This pamphlet prescribes Army policy on ammunition and explosives (also referred to as military munitions) safety standards. It implements the safety requirements of DODM 6055.09–M.

**Applicability.** This pamphlet applies to the active Army, the Army National Guard/Army National Guard of the United States, and the U.S. Army Reserve, unless

otherwise stated. It also applies to all Army civilian personnel in a duty status, on or off a DOD installation; and to all persons at any time on an Army installation. DOD military munitions under U.S. title, even though stored in a host country, remain the responsibility of the U.S. Commander. Storage will conform with Army standards for explosives safety unless the use of more stringent criteria has been agreed to or is mandatory. This pamphlet is applicable during full mobilization.

**Proponent and exception authority.** The proponent for this pamphlet is the Chief of Staff, Army. The proponent has the authority to approve exceptions to this pamphlet that are consistent with applicable controlling laws and regulations. The proponent has delegated approval authority to a division chief within the proponent agency or its direct reporting unit or field operating agency, in the grade of colonel or the civilian equivalent. Activities may request a waiver to this pamphlet by providing justification that includes a full analysis of the expected benefits and must include formal review by the activity's senior legal officer. All waiver requests will be endorsed by the command

or senior leader of the requesting activity and forwarded through their higher headquarters to the policy proponent. Refer to AR 25–30 for specific guidance.

**Suggested improvements.** Users of this regulation are invited to send comments and suggested improvements on DA Form 2028 (Recommended Changes to Publications and Blank Forms) directly to Office of the Director, Army Safety (DACS–SF), 2221 South Clark Street, Crystal Plaza 6, Suite 1107, Arlington, VA 22202.

**Distribution.** This publication is available in electronic media only and is intended for command levels A, B, C, D, and E for the active Army, the Army National Guard/Army National Guard of the United States, and the U.S. Army Reserve.

---

## Contents (Listed by paragraph and page number)

### Chapter 1

#### Explosives Safety Program Management, *page 1*

Purpose • 1–1, *page 1*

References • 1–2, *page 1*

Explanation of abbreviations and terms • 1–3, *page 1*

Provisions • 1–4, *page 1*

Explosives safety management programs • 1–5, *page 1*

Functions of safety managers • 1–6, *page 2*

Explosives safety support • 1–7, *page 3*

Explosives safety training • 1–8, *page 4*

Explosives safety inspections • 1–9, *page 5*

Ammunition and explosive transportation surveys • 1–10, *page 5*

Garrison or installation ammunition and explosive location maps • 1–11, *page 5*

---

\*This pamphlet supersedes DA Pam 385–64, dated 15 December 1999.

## Contents—Continued

Operational range safety • 1–12, *page 6*  
Certificates of risk acceptance • 1–13, *page 6*

### Chapter 2

#### General Safety, *page 10*

Imminent danger • 2–1, *page 10*  
Hazard analysis and risk assessment • 2–2, *page 10*  
Personnel qualifications • 2–3, *page 12*  
Use of written procedures • 2–4, *page 12*  
Personnel and explosives limits • 2–5, *page 12*  
Handling and movement precautions • 2–6, *page 12*  
Housekeeping • 2–7, *page 13*  
Testing, disassembly, and modification of ammunition and explosive • 2–8, *page 14*  
Explosive ordnance disposal training aids • 2–9, *page 14*  
Field safety • 2–10, *page 15*  
Rod and gun clubs • 2–11, *page 15*  
Public demonstrations, exhibitions, and celebrations • 2–12, *page 16*  
Static or public display • 2–13, *page 16*  
Explosives training aids for military working dogs • 2–14, *page 16*  
Outdoor recreational and cultural activities • 2–15, *page 16*  
Unexploded ordnance safety education • 2–16, *page 17*  
Material handling equipment • 2–17, *page 17*  
Amnesty • 2–18, *page 19*

### Chapter 3

#### Principles of Ammunition and Explosive Storage, *page 20*

General requirements • 3–1, *page 20*  
Magazine storage of ammunition and explosive • 3–2, *page 21*  
Outdoor storage • 3–3, *page 23*  
Storage of specific types of ammunition and explosive • 3–4, *page 23*  
Inert or dummy ammunition and explosive • 3–5, *page 25*  
Modifications of ammunition and explosive and ammunition and explosive-related equipment for reuse • 3–6, *page 26*  
Unserviceable ammunition and explosive • 3–7, *page 26*  
Storage of captured enemy ammunition • 3–8, *page 27*  
Chemical munitions (ammunition and explosive) • 3–9, *page 27*  
Chemical Group B chemical agents • 3–10, *page 29*  
Storage of Chemical Group B chemical munitions • 3–11, *page 29*  
First aid for Chemical Group B chemical agents • 3–12, *page 29*  
Leaking Chemical Group B munitions and containers • 3–13, *page 29*  
Removal of spilled Chemical Group B agent • 3–14, *page 29*  
Fire in magazines containing Chemical Group B agent munitions • 3–15, *page 29*  
Chemical Group C fills • 3–16, *page 30*  
Storage for Chemical Group C munitions • 3–17, *page 30*  
Leaking Chemical Group C munitions • 3–18, *page 30*  
Removal of Chemical Group C chemical contamination • 3–19, *page 31*  
Fire in a magazine containing Chemical Group C munitions • 3–20, *page 31*  
Chemical Group D chemical fills • 3–21, *page 31*  
Storage of Chemical Group D munitions • 3–22, *page 31*  
Special protective equipment for Chemical Group D munitions • 3–23, *page 31*  
First aid for Chemical Group D chemicals • 3–24, *page 31*  
Leaking Chemical Group D munitions • 3–25, *page 31*  
Fire in magazine containing Chemical Group D munitions • 3–26, *page 32*  
Termination of use of facilities storing ammunition and explosives • 3–27, *page 32*

## Contents—Continued

### Chapter 4

#### **Safety Site Planning**, *page 32*

Explosives and toxic chemical safety site plans • 4-1, *page 32*

Explosives safety site plan contents • 4-2, *page 34*

### Chapter 5

#### **Explosives Licensing**, *page 34*

Explosives licenses • 5-1, *page 34*

Procedures • 5-2, *page 34*

Required information • 5-3, *page 35*

### Chapter 6

#### **Fire Prevention, Protection, and Suppression**, *page 35*

Fire prevention management • 6-1, *page 35*

Instructions for fighting fires involving ammunition or explosives • 6-2, *page 36*

Smoking • 6-3, *page 36*

Training • 6-4, *page 37*

Fire drills • 6-5, *page 37*

Fire exit drills • 6-6, *page 37*

Alarms • 6-7, *page 37*

Fire prevention requirements • 6-8, *page 37*

Firebreaks • 6-9, *page 39*

Auxiliary firefighting equipment - fire extinguishers • 6-10, *page 40*

Storage of water for firefighting • 6-11, *page 40*

Public withdrawal distances • 6-12, *page 40*

Firefighting guidance symbols • 6-13, *page 40*

Posting fire symbols • 6-14, *page 45*

Exceptions on posting fire symbols • 6-15, *page 45*

Posting chemical hazard symbols • 6-16, *page 45*

Procedures for chemical agents and other toxic substances • 6-17, *page 45*

Automatic sprinkler systems • 6-18, *page 45*

Deluge systems for explosives operations • 6-19, *page 46*

Emergency planning • 6-20, *page 48*

### Chapter 7

#### **Hazard Classification and Compatibility Groups**, *page 50*

Explosives hazard classification procedures • 7-1, *page 50*

Storage principles • 7-2, *page 51*

Mixed storage • 7-3, *page 51*

Compatibility groups • 7-4, *page 52*

Extremely insensitive detonating substance and ammunition • 7-5, *page 53*

Class 1 or 6 chemical agent hazards or combined chemical agent and explosives hazards • 7-6, *page 53*

Underground storage • 7-7, *page 53*

### Chapter 8

#### **Explosives safety Separation Distance (Quantity-Distance)**, *page 55*

Explosives quantity-distance • 8-1, *page 55*

Quantity-distance exceptions • 8-2, *page 56*

Arms room storage • 8-3, *page 57*

Structural response to blast • 8-4, *page 57*

Substantial dividing walls • 8-5, *page 62*

Calculation of explosives quantity • 8-6, *page 62*

Net explosive weight for mixed hazard class/division • 8-7, *page 62*

Calculating quantity distance for two or more potential explosion sites • 8-8, *page 63*

Quantity distance relationships of DOD components • 8-9, *page 64*

## **Contents—Continued**

- Criteria for Non-DOD Explosives Activities (AE Operations and Storage) on U.S. Army Garrisons or installations
  - 8–10, *page 64*
- Subdivision of explosives quantities • 8–11, *page 65*
- Interpolation and extrapolation • 8–12, *page 65*
- Measuring distance • 8–13, *page 65*
- Ammunition and explosives risk • 8–14, *page 66*
- Blast considerations • 8–15, *page 66*
- Magazine requirements and orientation • 8–16, *page 67*
- Exposed site • 8–17, *page 73*
- Blast tables for HD 1.1 ammunition and explosives • 8–18, *page 79*
- Fragments • 8–19, *page 79*
- Hazard division 1.1 fragments • 8–20, *page 79*
- Firebrands • 8–21, *page 97*
- Moderate fire producing • 8–22, *page 99*
- Extremely insensitive ammunition and explosives • 8–23, *page 99*
- Propulsive units • 8–24, *page 101*
- The same Multiple operations in single building • 8–25, *page 101*
- Public traffic routes • 8–26, *page 101*
- Transportation mode change locations • 8–27, *page 102*
- Remote operations (see glossary) • 8–28, *page 102*
- Range operations • 8–29, *page 111*
- Explosive ordnance disposal operations • 8–30, *page 116*
- Demilitarization processing equipment and operations for expended .50-caliber and smaller cartridge casings • 8–31, *page 117*
- Airfields, heliports, and seadromes • 8–32, *page 117*
- Pier and wharf facilities • 8–33, *page 120*

## **Chapter 9**

### **Explosives Safety in Military Contingency Operations, *page 126***

- Applicability of provisions outside the United States • 9–1, *page 126*
- Site plan and licensing process • 9–2, *page 127*
- Asset preservation distances • 9–3, *page 127*
- Basic load ammunition holding areas • 9–4, *page 127*
- Combat load storage in other than BLAHAs • 9–5, *page 131*
- Vehicle and equipment maintenance • 9–6, *page 132*
- Fire prevention • 9–7, *page 132*
- Surveillance • 9–8, *page 132*
- Storage • 9–9, *page 132*
- Combat load storage ammunition holding areas in the United States • 9–10, *page 132*
- General requirements for training operations • 9–11, *page 133*
- Upload exercises • 9–12, *page 133*
- Combat configured loads • 9–13, *page 133*
- Aviation operations at basic load ammunition holding areas • 9–14, *page 134*
- Forward area rearm and refuel points • 9–15, *page 134*
- Airfield operations • 9–16, *page 134*
- Static missile battery separation • 9–17, *page 138*
- Separation from fuel • 9–18, *page 139*

## **Chapter 10**

### **Wartime Operations, *page 139***

- General requirements • 10–1, *page 139*
- Theater and corps ammunition storage areas • 10–2, *page 140*
- Storage at the ammunition supply points and ammunition transfer points • 10–3, *page 140*
- Short-term ammunition transfer points storage • 10–4, *page 141*
- Field storage and handling areas • 10–5, *page 141*

## **Contents—Continued**

Transportation within the theater of operations • 10–6, *page 141*  
Modular storage • 10–7, *page 142*  
Policy for captured enemy ammunition and explosives • 10–8, *page 142*  
Standards and procedures for safe handling, transportation, storage, and disposal of captured enemy ammunition  
• 10–9, *page 142*  
Ammunition turn-in at the cessation of hostilities • 10–10, *page 144*  
Emergency destruction of ammunition • 10–11, *page 145*

### **Chapter 11**

#### **Underground Storage, *page 147***

Underground storage • 11–1, *page 147*  
Design of underground storage facilities • 11–2, *page 148*  
Explosion effects in underground storage sites • 11–3, *page 149*  
Protection provided • 11–4, *page 149*  
Chamber separation requirements • 11–5, *page 149*  
Chamber cover thickness • 11–6, *page 150*  
External quantity-distance determinations • 11–7, *page 150*

### **Chapter 12**

#### **Energetic Liquids, *page 165***

Energetic liquids • 12–1, *page 165*  
Determination of energetic liquids quantity • 12–2, *page 165*  
Measurement of separation distances • 12–3, *page 165*  
Hazard classification of energetic liquids • 12–4, *page 165*  
Specific hazardous locations • 12–5, *page 166*  
Contaminated energetic liquids • 12–6, *page 168*

### **Chapter 13**

#### **Military Working Dog Explosives Search Training, *page 175***

General • 13–1, *page 175*  
Safety precautions • 13–2, *page 175*

### **Chapter 14**

#### **Maintenance of Ammunition and explosives, *page 176***

General information • 14–1, *page 176*  
Safety requirements • 14–2, *page 176*  
Operational shields • 14–3, *page 177*  
Equipment for shielded operations • 14–4, *page 179*  
Tools, equipment, and supplies • 14–5, *page 179*  
Protection of primers • 14–6, *page 179*  
Cleaning ammunition • 14–7, *page 179*  
Spray painting • 14–8, *page 179*  
Electrostatic paint spraying and detearing of inert items in nonhazardous locations • 14–9, *page 180*  
Infrared ray drying • 14–10, *page 180*  
Drying freshly painted loaded ammunition • 14–11, *page 181*  
Heat sealing equipment • 14–12, *page 181*  
Soldering containers • 14–13, *page 181*  
Thread cleaning • 14–14, *page 181*  
Inert scrap components and packaging materials • 14–15, *page 181*  
Sand or shot blasting operations • 14–16, *page 182*  
Location of sand or shot blasting operations in explosives storage areas • 14–17, *page 182*  
Sand or shot blasting operations within a building in an operating line • 14–18, *page 183*  
Electrical testing of ammunition and ammunition components • 14–19, *page 183*  
Profile and alignment gaging operations • 14–20, *page 183*  
Collection of explosives dusts • 14–21, *page 183*

## **Contents—Continued**

Location of collection chambers • 14–22, *page 184*  
Design and operation of collection systems • 14–23, *page 184*  
Solid propellant collection • 14–24, *page 185*  
Destruction of solid wastes • 14–25, *page 186*  
Assembly and crimping of complete rounds • 14–26, *page 186*  
Rotational speeds for equipment used in field ammunition operations • 14–27, *page 186*  
Machining of explosives • 14–28, *page 186*  
Operational shields for munitions loading • 14–29, *page 187*

### **Chapter 15**

#### **Demilitarization, *page 187***

Demilitarization • 15–1, *page 187*  
Methods • 15–2, *page 188*  
Safety precautions • 15–3, *page 188*  
Site selection for burning or demolition grounds • 15–4, *page 188*  
Burning sites • 15–5, *page 188*

### **Chapter 16**

#### **Construction, *page 189***

Construction considerations • 16–1, *page 189*  
Buildings • 16–2, *page 189*  
Interior finishes and floors • 16–3, *page 190*  
Firewalls • 16–4, *page 190*  
Building exits • 16–5, *page 190*  
Safety chutes • 16–6, *page 190*  
Emergency exits and fire escapes • 16–7, *page 190*  
Stairways • 16–8, *page 190*  
Fixed ladders • 16–9, *page 190*  
Platforms, runways, and railings • 16–10, *page 190*  
Passageways • 16–11, *page 190*  
Roads, walks, and gates • 16–12, *page 190*  
Windows and skylights • 16–13, *page 191*  
Drains and sumps • 16–14, *page 192*  
Hardware • 16–15, *page 192*  
Tunnels • 16–16, *page 192*  
Powerhouse equipment • 16–17, *page 192*  
Refrigeration • 16–18, *page 192*  
Laundries • 16–19, *page 192*  
Steam for processing and heating • 16–20, *page 192*  
Ventilation • 16–21, *page 193*  
Electrical equipment • 16–22, *page 193*  
Collection of explosives dusts • 16–23, *page 193*  
Automatic sprinkler systems • 16–24, *page 194*  
Barricades and earth cover for magazines • 16–25, *page 194*  
Policy on protective construction • 16–26, *page 198*  
Strengthening (hardening of buildings) • 16–27, *page 199*  
Substantial dividing walls • 16–28, *page 199*

### **Chapter 17**

#### **Electrical Hazards and Protection, *page 201***

##### *Section I*

##### *Electrical Service and Equipment, page 201*

Overview • 17–1, *page 201*  
Hazardous locations • 17–2, *page 201*



## **Contents—Continued**

Approved equipment • 17–3, *page 203*  
Maintenance of electrical equipment • 17–4, *page 203*  
Electrical service lines in explosives areas • 17–5, *page 203*  
Electrical motors for hazardous locations • 17–6, *page 204*  
Portable lighting systems • 17–7, *page 204*  
Permanent lighting for storage magazines • 17–8, *page 204*  
Flexible cords • 17–9, *page 204*

### *Section II*

*Static electricity, page 204*  
Static electricity charge dissipation subsystem • 17–10, *page 204*  
Ordnance grounds (static grounds) • 17–11, *page 208*  
Instrument grounds • 17–12, *page 208*

### *Section III*

*Grounding, page 208*  
Explosives facility grounding • 17–13, *page 208*  
Earth electrode subsystem • 17–14, *page 209*  
Hazards of electromagnetic radiation to electroexplosive devices • 17–15, *page 215*

### *Section IV*

*Lightning Protection, page 219*  
Fundamental principles of lightning protection • 17–16, *page 219*  
Locations requiring an lightning protection system • 17–17, *page 219*  
Locations not requiring lightning protection • 17–18, *page 220*  
Requirements for lightning protection systems • 17–19, *page 220*  
Types of lightning protection systems • 17–20, *page 221*  
General prohibitions • 17–21, *page 222*  
Bonding • 17–22, *page 222*  
Lightning warning systems • 17–23, *page 223*  
Structural grounds • 17–24, *page 223*  
Grounding • 17–25, *page 223*  
Surge protection • 17–26, *page 223*  
Visual inspection requirements • 17–27, *page 224*  
Electrical testing requirements • 17–28, *page 224*  
Records • 17–29, *page 224*  
Truck holding areas • 17–30, *page 224*  
Lightning protection for empty facilities • 17–31, *page 224*

## **Chapter 18**

### **Special storage procedures for waste military munitions, page 226**

Scope and applicability • 18–1, *page 226*  
Certificates of risk, acceptance, waivers, and exemptions • 18–2, *page 226*  
Requirements for storage of waste military munitions under conditional exemption • 18–3, *page 226*  
Other storage standards • 18–4, *page 227*  
Reporting • 18–5, *page 227*  
Closure of facilities storing waste munitions under CE • 18–6, *page 228*  
Closure of facilities storing waste military munitions under Resource Conservation and Recovery Act • 18–7, *page 228*

## **Chapter 19**

### **Real Property Known or Suspected to Contain Munitions and Explosives of Concern, page 228**

General • 19–1, *page 228*  
Purpose and scope • 19–2, *page 228*  
Identification and control of areas known or suspected to contain munitions and explosives of concern • 19–3, *page 229*

## **Contents—Continued**

Identification and control of munitions response site known or suspected to contain munitions and explosives of concern at formerly used defense sites • 19–4, *page 230*

General explosives safety principles for munitions responses to munitions and explosives of concern • 19–5, *page 230*

Special considerations • 19–6, *page 231*

Real property (buildings and installed equipment) • 19–7, *page 233*

Submunitions with an high explosive fill • 19–8, *page 244*

Unexploded ordnance • 19–9, *page 245*

Firefighting in areas known or suspected to contain munitions and explosives of concern • 19–10, *page 246*

Controlled burns in areas known or suspected to contain munitions and explosives of concern • 19–11, *page 246*

Quantity-distance criteria for munitions response actions • 19–12, *page 247*

DOD required safety submissions • 19–13, *page 249*

DOD required safety submissions for munitions responses to munitions and explosives of concern • 19–14, *page 250*

“No DOD action indicated” or “no further action” MRESS • 19–15, *page 250*

TCRA MRESS • 19–16, *page 250*

Explosives safety site plan for surface or intrusive investigation in support of a munitions response to MEC • 19–17, *page 251*

Construction support munitions response explosives safety submission • 19–18, *page 251*

Selected munitions response munitions response explosives safety submission • 19–19, *page 251*

Amendments and corrections to munitions response explosives safety submission and site plans • 19–20, *page 253*

After action reports • 19–21, *page 254*

Transfer or lease of real property • 19–22, *page 254*

Change of use of real property • 19–23, *page 255*

## **Chapter 20**

### **Transportation of Ammunition and Explosives, *page 255***

#### *Section I*

##### *General Requirements, page 255*

General information • 20–1, *page 255*

Certification of personnel involved with transportation • 20–2, *page 255*

Hazard classification • 20–3, *page 255*

Preparation for shipment • 20–4, *page 255*

Compatibility of explosives in transportation • 20–5, *page 256*

Vehicle general safety requirements • 20–6, *page 256*

Inbound motor shipment of ammunition and explosives • 20–7, *page 256*

Outbound motor shipment of ammunition and explosives • 20–8, *page 257*

Secure holding area for explosive shipments • 20–9, *page 257*

On-post explosives movements • 20–10, *page 257*

Passengers in or on Government vehicles transporting explosives • 20–11, *page 258*

#### *Section II*

##### *Rail, Air, and Water Transport, page 258*

Railroad transportation • 20–12, *page 258*

Air transportation • 20–13, *page 259*

Water transportation • 20–14, *page 260*

## **Chapter 21**

### **Storage and handling of commercial explosives, *page 260***

Background • 21–1, *page 260*

Use • 21–2, *page 261*

Procedures • 21–3, *page 261*

Commercial dynamite • 21–4, *page 261*

## **Appendixes**

**A.** References, *page 263*

## Contents—Continued

- B. Earth Electrode Subsystem Test and Inspection, *page 269*
- C. Inspection and Test of Static Electricity Charge Dissipation Subsystem, *page 275*
- D. Inspection and Test of Lightning Protection Subsystems, *page 277*
- E. Field Expedient Grounding Techniques, *page 278*
- F. Safe Conveyor Separation for Ammunition/Explosives, *page 279*
- G. Standard designs for explosives facilities, *page 285*
- H. The 100-Foot Zone of Protection, *page 287*

### Table List

- Table 1-1: Army explosive safety courses, *page 4*
- Table 1-2: List of explosives safety standard tables and locations, *page 6*
- Table 2-2: Probabilities for common ammunition and explosive activities and environments, *page 11*
- Table 3-1: Quantity distance for captured enemy ammunition field storage and handling areas, *page 27*
- Table 6-1: Extinguishing agents for fires, *page 48*
- Table 6-2: Fire symbol hazards and actions, *page 49*
- Table 6-3: Emergency withdrawal distances for nonessential personnel, *page 49*
- Table 6-4: Fire divisions and associated hazards, *page 50*
- Table 6-5: Fire division symbols, *page 50*
- Table 6-6: Chemical agents and fillers contained in ammunition and the chemical hazard symbols required in storage, *page 50*
- Table 7-1: Storage compatibility groups, *page 52*
- Table 7-2: Storage compatibility mixing chart, *page 53*
- Table 7-3: Extremely insensitive detonating substance ammunition hazard divisions, *page 54*
- Table 7-4: Quantity-distance criteria for configuration of hazard division 1.6 components and assemblies with other hazard division components, *page 55*
- Table 8-1: Safe separation distances and expected severities (HD 1.1), *page 58*
- Table 8-2: Mixing of hazard divisions for quantity-distance computations, *page 62*
- Table 8-3: Criteria for Non-DOD explosives activities on U.S. Army garrisons or installations, *page 65*
- Table 8-4: Measuring distance from exposed site, *page 65*
- Table 8-5: Type of exposed sites and safe separation distance required, *page 74*
- Table 8-6: QD for unprotected aboveground service tanks supporting explosives storage or operating complexes, *page 79*
- Table 8-7: HD 1.1 IBD and PTRD, *page 80*
- Table 8-8: HD 1.1 ILD from PESs other than earth-covered magazines, *page 82*
- Table 8-9: HD 1.1 ILD from earth-covered magazines to the ES, *page 83*
- Table 8-10: HD 1.1 intermagazine hazard factors and distances, *page 86*
- Table 8-11: Intermagazine separation for barricaded storage modules for mass detonating explosives, *page 88*
- Table 8-12: HD 1.1 Hazardous Fragment Distances, *page 88*
- Table 8-13: Examples of where minimum fragment distance or firebrand distance is required, *page 89*
- Table 8-14: Examples when minimum fragment and firebrand distances need not be applied, *page 89*
- Table 8-15: Hazardous fragment distances for open stacks of selected hazard division 1.1 items, *page 90*
- Table 8-16: Unknown Fragment Distance for HD 1.1, *page 91*
- Table 8-17: HD 1.2.1, 1.2.2, and 1.2.3 Mixing Rules, *page 93*
- Table 8-18: Summary of HD 1.2.1, 1.2.2 and 1.2.3 Quantity-Distance Requirements, *page 93*
- Table 8-19: HD 1.2.1 IBD, PTRD, and ILD QD, *page 95*
- Table 8-20: Minimum fragment distances for HD 1.2.1 items stored in structures, which can contribute to the debris hazard, *page 96*
- Table 8-21: HD 1.2.2 IBD, PTRD, and ILD QD, *page 97*
- Table 8-22: Firebrand distances for HD 1.3 QD, *page 98*
- Table 8-23: Mass Fire Producing - HD 1.4 Ammunition and Explosives, *page 100*

## Contents—Continued

- Table 8–24: QD distances for HD 1.6 ammunition, *page 100*
- Table 8–25: Thermal flux calculations, *page 104*
- Table 8–26: Impulse noise protection decision table, *page 104*
- Table 8–27: Impulse noise zones measured in feet from intentional detonations, *page 105*
- Table 8–28: Impulse noise B-duration (estimated for various NEWs and distances) (See notes 1 thru 5 below), *page 106*
- Table 8–29: Impulse noise zones and required protections with maximum permissible number of detonations per day, *page 111*
- Table 8–30: Default maximum case maximum fragment distances versus diameter for international detonations (see notes 1 - 6 below), *page 112*
- Table 8–31: Maximum case fragment ranges for selected single item detonations (see notes 1 thru 3 below), *page 114*
- Table 8–32: Required blast overpressure protection distance in feet for nonessential personnel at ranges used for detonating ammunition for demilitarization, demonstration, or explosives ordnance disposal, *page 116*
- Table 8–33: Quantity-distance application for airfields, *page 118*
- Table 8–34: HD 1.1 QD for military aircraft parking areas, *page 119*
- Table 8–35: Measurement of separation distances for ships, piers, and anchorages, *page 121*
- Table 8–36: Quantity-distance for maritime prepositioning ships, *page 122*
- Table 8–37: Application of port facilities quantity-distance, *page 124*
- Table 8–38: Quantity-distance separation of ships, *page 125*
- Table 8–39: Variation of MPS quantity-distance factors with loadout, *page 125*
- Table 8–40: Quantity-distance separations for pier and wharf facilities (NEW in million pound increments), *page 125*
- Table 9–1: Quantity-distance for armored vehicles, *page 131*
- Table 9–2: Minimum hazard factor for hardened aircraft shelters for propagation prevention, *page 135*
- Table 9–3: Minimum hazard factor for hardened aircraft shelters for asset prevention, *page 136*
- Table 9–4: Quantity-distance from a U.S. third-generation hardened aircraft shelter potential explosion site to an unhardened exposed site, *page 137*
- Table 9–5: Quantity-distance for asset preservation at airfields, *page 137*
- Table 10–1: Wartime compatibility chart, *page 145*
- Table 10–2: Quantity distance for field storage and handling areas, *page 146*
- Table 10–3: HD 1.1 quantity distance requirements using minimum separation and asset preservation criteria, *page 146*
- Table 11–1: External quantity-distance determinations for HD 1.1 and 1.3 materials, *page 154*
- Table 11–2: Chamber separation, *page 155*
- Table 11–3: Distance to protect against ground shock, *page 156*
- Table 11–4: Distance to protect against hard rock debris, *page 158*
- Table 11–5: Distance to protect against soft rock debris, *page 159*
- Table 11–6: Functions of loading density, *page 160*
- Table 11–7: Values for Ratio  $D_{HYD}/V_{E1}^{1/2.8}$ , *page 161*
- Table 11–8: Scaled inhabited building distance for airblast without mitigating, *page 162*
- Table 11–9: Distance versus overpressure along the centerline, *page 163*
- Table 11–10: Inhabited building distance distances to protect against airblast, *page 164*
- Table 12–1: Energetic liquid compatibility group, *page 166*
- Table 12–2: Hazard classification and minimum quantity distance for energetic liquids, *page 168*
- Table 12–3: Factors to use when converting gallons of energetic liquids into pounds, *page 169*
- Table 12–4: Energetic liquid explosive equivalents |5, *page 170*
- Table 12–5: Quantity-distance criteria for Occupational Safety and Health Administration/National Fire and Protection Association Class I - III flammable and combustible energetic liquids storage in detached buildings or tanks, *page 171*
- Table 12–6: Quantity-distance criteria for energetic liquid oxidizer (excluding liquid oxygen) storage in detached buildings or tanks, *page 171*
- Table 12–7: Quantity-distance criteria for liquid oxygen, *page 172*
- Table 17–1: Grounding system inspection and test requirements, *page 217*
- Table 17–2: Ground rod quantity requirements, *page 218*
- Table 17–3: Minimum safe distance from transmitter antennas, *page 218*

## Contents—Continued

- Table 17-4: Lightning protection systems, *page 225*  
Table 19-1: Absorption of explosives as a function of type of material and phase of explosive, *page 241*  
Table 19-2: DOD required safety submissions, *page 250*  
Table 21-1: Turning of commercial dynamite, *page 262*  
Table B-1: Test probe C and P distances, *page 274*  
Table F-1: Safe conveyor spacing, *page 279*

## Figure List

- Figure 2-1: Severity Chart: Blast and fragmentation effects to exposed sites/personnel, *page 11*  
Figure 6-1: Fire symbols, *page 41*  
Figure 6-2: Chemical hazard symbols, *page 43*  
Figure 6-3: Chemical hazards symbols and actions, *page 44*  
Figure 8-1: Classification of ammunition and explosives, *page 56*  
Figure 8-2: Typical Eight-Cell Open Storage Module, *page 61*  
Figure 8-3: Example of Multiple Potential Explosion Sites, *page 64*  
Figure 8-4: Magazine Orientation - Explanation of sectors, *page 68*  
Figure 8-4: Magazine Orientation - Public traffic rout exposure—Continued, *page 69*  
Figure 8-4: Magazine Orientation - Alternating side-to-side exposure—Continued, *page 69*  
Figure 8-4: Magazine Orientation - Multi-magazine exposure—Continued, *page 70*  
Figure 8-4: Magazine Orientation - Angle side-to-side exposure—Continued, *page 70*  
Figure 8-4: Magazine Orientation - Front to side exposure—Continued, *page 71*  
Figure 8-4: Magazine Orientation - Front-to-front exposure—Continued, *page 72*  
Figure 8-4: Magazine Orientation - Multifaceted ECM exposures—Continued, *page 73*  
Figure 8-5: HQ 1.1 guide for intermagazine distance, *page 85*  
Figure 8-6: Example of sparsely populated locations, *page 103*  
Figure 8-7: Impulse noise zones from intentional detonations, *page 104*  
Figure 8-8: Explosives anchorage circle, *page 122*  
Figure 8-9: Hazard factors affecting explosives ship and barge QD, *page 123*  
Figure 9-1: Quantity-distance table for basic load ammunition holding areas, *page 130*  
Figure 9-1: Quantity-distance table for basic load ammunition holding areas—Continued, *page 131*  
Figure 9-2: Hardened aircraft shelter as an exposed site, *page 138*  
Figure 9-3: Hardened aircraft shelter as a potential explosion site, *page 138*  
Figure 11-1: Typical underground facilities, *page 148*  
Figure 11-2: Constant pressure contour, *page 151*  
Figure 11-3: Debris dispersal functions, *page 152*  
Figure 11-4: Effective overpressure at the opening, *page 163*  
Figure 11-5: Allowable overpressure at inhabited building distance, *page 163*  
Figure 12-1: Quantity-distance criteria for liquid hydrogen and bulk quantities of hydrazines, *page 173*  
Figure 12-1: Quantity-distance criteria for liquid hydrogen and bulk quantities of hydrazines <sup>1</sup>-continued, *page 174*  
Figure 12-1: Quantity-distance criteria for liquid hydrogen and bulk quantities of hydrazines <sup>1</sup>-continued, *page 175*  
Figure 16-1: Determination of barricade height, *page 195*  
Figure 16-2: Determination of barricade length, *page 196*  
Figure 16-3: Barricade locations, *page 197*  
Figure 16-4: Sensitivity groups, *page 200*  
Figure 17-1: Typical ground rod installation, *page 210*  
Figure 17-2: Typical multiple ground rod installation, *page 211*  
Figure 17-3: Typical ground loop installation, *page 211*  
Figure 17-4: U.S. Navy designed earth electrode subsystem, *page 212*  
Figure 17-5: Typical grid installation, *page 213*  
Figure 17-6: Typical radial installation, *page 214*  
Figure 17-7: Typical buried plates or cones installation, *page 215*  
Figure 17-8: Safe separation distance equations, *page 219*  
Figure 17-9: Alternate grounding methods for overhead ground wire protection, *page 222*  
Figure 19-1: Phase and extent of explosives residues, *page 235*

## Contents—Continued

- Figure 19-1: Phase and extent of explosives residues—continued, *page 236*  
Figure 19-1: Phase and extent of explosives residues—continued, *page 237*  
Figure 19-1: Phase and extent of explosives residues—continued, *page 238*  
Figure 19-1: Phase and extent of explosives residues—continued, *page 239*  
Figure 19-1: Phase and extent of explosives residues—continued, *page 240*  
Figure B-1: Measurement of soil resistance, *page 271*  
Figure B-2: Resistance determination of a small site, *page 272*  
Figure B-3: Fall of potential method for measuring the resistance of earth electrodes, *page 273*  
Figure B-4: Fall of potential resistance to earth test, *page 274*  
Figure D-1: Testing lightning protection systems, *page 278*  
Figure H-1: Zone of Protection Test, *page 288*  
Figure H-2: Zone of protection for integral systems, *page 288*  
Figure H-3: Illustrated zone of protection, *page 289*  
Figure H-4: Zone of protection geometric concept, *page 290*  
Figure H-5: Adequate protection not penetrating earth cover, *page 291*  
Figure H-6: Adequate protection penetrating earth cover, *page 291*  
Figure H-7: Inadequate protection penetrating earth cover, *page 292*

## Glossary

# Chapter 1

## Explosives Safety Program Management

### 1-1. Purpose

This pamphlet explains the Army's safety criteria and standards for operations involving ammunition and explosives (AE) (also referred to as Military Munitions) prescribed by AR 385-10, DOD Directive (DODD) 6055.9E, and DODM 6055.09-M for the U.S. Army, and Government-owned, contractor-operated facilities and property.

### 1-2. References

Required and related publications and prescribed and referenced forms are listed in appendix A. DA Form 7632 (Certificate of Risk Acceptance), will be referred to as acronym "CORA" throughout this publication.

### 1-3. Explanation of abbreviations and terms

Abbreviations and special terms used in this pamphlet are explained in the glossary.

### 1-4. Provisions

This pamphlet includes mandatory procedures and guidance as well as preferred and acceptable methods of accomplishment.

a. The words "shall," "will," and "must" are used to state mandatory requirements. Deviation from these provisions requires a DA Form 7632 per provisions of AR 385-10 and DA Pamphlet (DA Pam) 385-30.

b. The word "should" indicates an optional or preferred method of accomplishment. Deviation from these provisions requires written authorization from the local commander/senior manager or designee.

c. The word "may" indicates an acceptable or suggested means of accomplishment.

### 1-5. Explosives safety management programs

a. Per AR 385-10, Army commands (ACOMs), Army service component commands (ASCCs), direct reporting units (DRUs) will develop, implement, and manage a written explosives safety management program (ESMP) as an element of their overall safety and occupational health program. In addition, units at and above the battalion level whose mission and functions involve AE will develop, implement, and manage a written ESMP as an element of their overall safety and occupational health program. The ESMPs will address the safety of AE during production, transportation, storage, handling, use, inspection, testing, maintenance, munition response actions, demilitarization, and disposal.

b. Commanders, at all levels, will establish and implement a written ESMP that, at a minimum, shall address the following:

(1) Appointment of an occupational safety and health manager per AR 385-10, qualified under the Office of Personnel Management standards, as the point of contact for all aspects of the Army Safety Program, including management of the ESMP.

(2) Compliance with DODD 6055.9E, DODI 6055.16, DODM 6055.09-M, AR 385-10, and this pamphlet.

(3) Assurance that subordinate organizations maintain an effective ESMP.

(4) Designation, in writing, of subordinate officials authorized to exercise CORA approval authority per AR 385-10 and DA Pam 385-30.

(5) Review of and concurrence on memorandums of agreement (MOAs) concerning the storage or disposal of non-DOD hazardous materials on Army real estate, consistent with the requirements of Section 2692, Title 10, United States Code (10 USC 2692) and with any delegation of authority necessary under 10 USC 2692.

(6) Integration of explosives safety into policy, procedures, and activities.

(7) Notification, as required by applicable laws, regulations or international agreements to which the United States is party, of affected local U.S. and host nation government officials to ensure communication of the risk of operations involving AE. Communications with host nation government officials shall be made in coordination with the U.S. Embassy.

c. Commanders of garrisons, installations and colonel-level (O6) and above commands and agencies with an ammunition or explosives mission will—

(1) Establish written explosives safety policy to implement AR 385-10 and this pamphlet that outlines the responsibilities of all organizations, including installation and tenant activities with an explosives missions. As part of the ESMP, an MOA or policy that outlines the ESMP requirements and responsibilities of both the garrison or installation commander and tenants will be created.

(2) Appoint an occupational safety and health manager per AR 385-10 who is qualified under Office of Personnel Management standards as the point of contact for all aspects of the ESMP.

(3) Ensure competent and qualified personnel initiate and review site plans, safety submissions, and AE facility designs and that garrison or installation master plans take into account ESMP requirements.

(4) Ensure personnel who initiate and review explosives safety certificates of risk acceptance for AE-related

operations, facilities or equipment are qualified to provide the commander with the information needed to make an informed decision regarding the risk being accepted.

(5) Ensure operating, training, and construction plans and budgets provide adequate resources to comply with ESMP requirements and to mitigate to the extent possible any explosives safety hazards per AR 385–10.

*d.* The ESMP shall prescribe requirements, responsibilities, and procedures for complying with AR 385–10, DA Pam 385–30, DA Pam 385–65, and this pamphlet. As applicable, the ESMP will address the following:

- (1) Oversight, management, coordination, and evaluation.
  - (2) Technical support requirements (such as, from quality assurance specialist (ammunition surveillance) (QASAS) personnel).
  - (3) Explosives safety training.
  - (4) Explosives safety surveys and inspections to determine compliance with AR 385–10 and this DA Pam.
  - (5) The development and approval of—
    - a.* Explosives safety policy, directives, and standing operating procedures (SOPs).
    - b.* The DDESB- or Army-required explosives safety submissions and licenses (per ACOM, ASCC, or DRU policy).
    - c.* Procedures for completing 1 certificates of risk acceptance.
    - d.* Certificates of compelling reason (CCRs).
  - (6) Investigating and reporting accidents, incidents and mishaps involving AE, including submission of serious incident reports (SIR) and chemical event reports (CER) and documentation and dissemination of explosives safety lessons learned.
  - (7) Contractor explosives safety requirements and oversight per their contract.
  - (8) Fire prevention and protection.
- e.* Garrison or installation safety offices will, when applicable, develop and administer the ESMP for all tenant units and activities.

#### **1–6. Functions of safety managers**

- a.* The ACOM, ASCC, and DRU safety directors shall—
- (1) Conduct periodic evaluations to ensure the effectiveness of their and subordinate commands' ESMPs.
  - (2) Keep their leadership and staff informed of ESMP requirements and issues, and the status of the commander's ESMP.
- b.* Garrison, installation, and unit safety managers will—
- (1) Serve as the point of contact for all ESMP-related actions.
  - (2) Identify requirement for explosives licenses, explosives safety site plans, safety submissions, and explosives safety certificates of risk acceptance, existing waivers and exemptions, and CCRs, and coordinate, as appropriate, with staff (for example, J–3/G–3/S–3, J–4/G–4/S–4, engineering, and logistics elements) and garrison, installation, and/or unit support personnel.
  - (3) Ensure all potential explosion sites (PESs) and exposed sites (ES), both military and civilian, are indicated on approved explosives safety site plans and submissions.
  - (4) Ensure that plans and protective construction designs for explosive manufacture, testing, storage, surveillance, maintenance, response actions, demilitarization, and disposal facilities are reviewed for compliance with safety standards, by appropriately trained personnel.
  - (5) Ensure a safety inspection is conducted at least annually for all areas where AE-related activities (for example, production, handling, storage, use, maintenance, munition response, demilitarization, and disposal) routinely occur. Maintain a list of all such areas and records of inspections.
  - (6) Monitor AE uploads and other activities that involve the transportation and storage of AE to ensure that pertinent requirements are met.
  - (7) Serve as the focal point for and coordinate ESMP requirements with tenant unit commanders; and provide concurrence on tenant unit ESMPs.
  - (8) Review the garrison or installation master plan and quantity-distance (QD) compliance for planned facilities on existing AE sites both prior to and after construction.
  - (9) Review policies, SOPs, and directives for compliance with explosives safety requirements.
  - (10) Review certificates of risk acceptance and certificates of compelling reason for completeness and accuracy prior to forwarding for approval.
  - (11) Maintain a list of approved certificates of risk acceptance, waivers, exemptions, and/or deviations; and advise incoming commanders of such and plans for correction of such situations.
  - (12) Actively participate in the garrison or installation master planning process and annually review the installation master plan to ensure construction is not planned inside explosives safety quantity distance (ESQD) arcs. When construction that is not related to AE operations is required within ESQD, ensure explosives safety site plans, submissions and explosives licenses are updated and approved at the appropriate level.



- (13) Ensure procedures are developed and in place for—
- (a) Maintaining fire symbols and chemical hazard symbols current with actual AE stored at a particular location.
  - (b) Ensuring that personnel responsible for managing AE keep current information on the type and location of AE storage and provide this information to safety and fire fighting personnel.
  - (c) Training of personnel responsible for AE-related operations, operational personnel including security personnel, and firefighters in fire symbols and chemical hazard symbols and in precautions and procedures for fighting fires when AE is involved.
  - (d) Existence of adequate communications between safety, fire fighting, security, emergency response, and ammunition surveillance and storage personnel.
  - (e) Maintenance of current maps, showing all explosives locations with fire and chemical hazard symbols, and current facility response cards and notebooks for AE storage by fire station communication centers.
- (14) Annually review (and document the review) the garrison's or installation's explosives location map to monitor encroachment within ESQD and ensure required explosives safety site plans, submissions and explosives licenses are accomplished.
- (15) Monitor selected AE operations conducted on Army garrisons or installations to ensure all DOD, Federal, State, local, and contractor participants understand and comply with applicable explosives safety standards.
- (16) Monitor, on a periodic basis, selected AE-related activities to evaluate explosives safety and the integration of risk management. Activities that should be monitored include, but may not be limited to the following:
- (a) AE storage, handling, and operating sites.
  - (b) AE transportation activities.
  - (c) AE disposal and demilitarization activities.
  - (d) Munitions response actions and access to MRS.
  - (e) Weapon systems modifications, special exercises, and test programs, particularly those that involve AE.
  - (f) Planning for contingencies.
  - (g) Combat load and reload operations.
  - (h) Explosives safety training records for unit personnel.
  - (i) Public demonstrations to include "Boss lift," "Organization day," "Open house," and "4th of July" type activities.
- (17) Assist commanders and staffs with resolving explosives safety concerns associated with real property known or suspected to contain munitions and explosives of concern (MEC).
- (18) Investigate and report AE accidents, incidents and mishaps, per DODM 6055.09–M, AR 385–10, and DA Pam 385–40, and document and disseminate explosives safety lessons learned.
- (19) Brief their command and staff, as necessary, to keep the leadership informed of explosives safety requirements and issues and the status of the commander's ESMP.

### **1–7. Explosives safety support**

The QASAS personnel must be adequately trained and qualified in ammunition/explosives safety, as well as ammunition surveillance to support ACOMs, ASCCs, DRUs, garrisons, installations, and shall be utilized to provide technical assistance to commanders and safety directors in the areas listed below. Safety directors and managers remain responsible for management of the Explosives Safety Program.

- a. Developing explosives safety site plans, submissions, and explosives licenses.
- b. Preparing explosives safety certificates of risk acceptance and CCRs.
- c. Reviewing protective construction designs for AE operational facilities (for example, production, manufacture, testing, storage, surveillance, maintenance, demilitarization, and disposal facilities) for compliance with explosives safety standards.
- d. Conducting safety inspections of AE handling, storage, use, maintenance, and disposal areas at least annually.
- e. Monitoring AE uploads and other activities that involve the transportation, storage or conduct of other AE-related operations for which a certificate of risk acceptance or CCR has been approved or is awaiting approval to ensure that pertinent requirements are met.
- f. Reviewing quantity-distance (QD) compliance of existing and planned facilities, both prior to and after construction.
- g. Reviewing SOPs and directives for compliance with explosives safety requirements.
- h. Assisting in the garrison or installation master planning process and reviewing, annually, the garrison or installation master plan to ensure construction is not planned within ESQD.
- i. Monitoring AE-related operations to assist Army units with understanding and complying with ESMP requirements.
- j. Monitoring and evaluating AE-related activities, including the following:
  - (1) Production, storage, handling, maintenance, operating, demilitarization, and disposal.
  - (2) Transportation.

- (3) Weapon systems modifications, special exercises, and test programs.
- (4) Contingency planning.
- (5) Combat load and reload operations.
- (6) Explosives safety training.
- k. Assisting in AE accident, incident and mishap investigations.
- l. Ensuring ESMP policies and procedures are followed for operational and tactical AE-related activities, such as—
  - (1) Siting and operation of ammunition holding areas (AHA) and ammunition transfer points (ATHP).
  - (2) Siting of uploaded tactical vehicles.
  - (3) Relief in place and transfer of authority (RIP/TOA) AE operations.
  - (4) Storage and processing of captured AE.
  - (5) AE retrograde, reconstitution, and reset activities in a tactical area of operation.

**1–8. Explosives safety training**

a. All personnel (supervisory and non-supervisory) who conduct AE-related activities shall complete explosives safety training appropriate for the activities that they perform. Such personnel shall receive periodic refresher training to help ensure the requisite level of knowledge of and competency in explosives safety.

b. In addition to any explosives safety training specified for career programs in AR 690–950 and related publications and training mandated by local, state, or federal requirements, explosives safety training shall be accomplished by ACOMs, ASCCs, DRUs, garrison, or installation and unit level as indicated in table 1–1.

**Table 1–1  
Army explosive safety courses**

Position	Explosives Safety management	Introduction to Ammunition (AMMO–45–DL)	U.S. Army Explosives Safety (AM–MO–63–DL)	Environmental Considerations for Ammunition Personnel (AM–MO–31–DL)	Risk Management for and Preparation of SOPs for A&E Operations (AM–MO–54)	Military Munitions Rule (AM–MO–68–DL)	DOD Contractors' Explosive Safety Standards (AM–MO–65)	U.S. Army Explosives Safety Quantity Distance (AM–MO–82)
Ammunition Area/Operation Supervisor		T(R)		I(R)	I(R)	I(M), A(M) <sup>3</sup>	I(R)	I(R)
Ammunition Handling/Operating Personnel		A(R)		I(R)	I(R)	I(M), A(M) <sup>3</sup>		
Safety	I(M)	T(M)			I(R)	I(M), A(M) <sup>3</sup>		
Safety Professionals with Explosives Safety Responsibilities	I(M)	T(M)	I(R)	I(R)	I(R)	I(M), A(M) <sup>3</sup>	I(R)	I(R)

Legend for Table 1-1:

- I=initial
- A=annual refresher
- t=triennial refresher
- M=mandatory
- R=recommended

Notes:

<sup>1</sup> AMMO designated numbers in parentheses are U.S. Army Defense Ammunition Center course numbers.

<sup>2</sup> Course numbers ending with DL indicate a distance learning course.

<sup>3</sup> Local courses providing the same degree and level of training are authorized.

- c. ACOM, ASCC, and DRU safety directors may—
  - (1) Approve alternative courses that are tailored to the organization's missions and functions provided the courses provide the same degree and level of training as those listed in table 1-1.
  - (2) Allow substitution of equivalent experience for the courses listed.
- d. Initial training, as specified in table 1-1, should be provided as soon as practical based on mission, funding, and resource constraints.
- e. Garrison, installation and unit safety managers shall, as appropriate, develop, and provide to training officers, the training programs required to ensure garrison, installation and unit personnel are trained to conduct AE operations in a safe manner. (See para 2-3 for personnel certification requirements.)

### **1-9. Explosives safety inspections**

Periodic (at least annual) inspections shall be conducted to evaluate the safety of explosives storage, packing, handling, surveillance, maintenance, demilitarization, and disposal activities. Inspections should use a team approach and include those elements with ESMP-related responsibilities in explosives safety (for example, safety, QASAS, logistics, and public works subject matter experts). Findings shall be documented and followed-up to ensure implementation and effectiveness of corrective measures. At the minimum, inspections shall address the following:

- a. Availability of approved explosives safety site plans, submissions and explosives licenses.
- b. Storage inventory, by facility, showing AE (by DODIC, national stock number (NSN), nomenclature, quantity, and total net explosive weight (NEW)) is in compliance with explosives safety standards.
- c. Comparison of actual storage versus that authorized by the approved explosives license or explosives safety site plan.
- d. Identification of storage compatibility violations.
- e. AE stacking and arrangement in magazines and adequacy of AE packaging comply with explosives safety standards and ammunition storage drawings.
- f. Operations conducted - versus those permitted - in and outside of magazines.
- g. Conditions under which AE are stored.
- h. Verification ESQD separation requirements stipulated in approved explosives licenses and explosives safety site plans.
- i. Evaluation of the safety of storage facilities, including adequacy of earth cover on magazines, adequacy of barricades, and condition of lightning protection systems and ventilators.
- j. Review of the latest lightning protection system inspection and test reports.
- k. Training of firefighters; adequacy of plans and procedures for responding to emergencies involving AE; conduct of fire drills; and availability and adequacy of firefighting equipment, fire symbols, and chemical hazard symbols.
- l. Identification and control of electrical hazards, including classification of hazardous locations and the availability and adequacy of approved equipment.
- m. Safety of material handling equipment.
- n. Safety of explosives renovation, modification, preservation, and packing activities.
- o. Adequacy and availability of explosives safety training of personnel involved in explosives storage, packing, handling, surveillance, maintenance, demilitarization, and disposal activities.
- p. Safe storage of waste military munitions (WMM).

### **1-10. Ammunition and explosive transportation surveys**

Garrisons, installations, and units shall conduct periodic surveys of sample AE transportation activities to evaluate implementation of AE transportation safety requirements. As above (see para 1-9), such surveys should use a team approach. At the minimum, surveys shall address the following:

- a. Compatibility of AE in transport.
- b. Training and certification of personnel involved in AE handling and transport.
- c. Inspection of motor vehicles, MILVANS, and trailers.
- d. Blocking and bracing.
- e. Placarding and labeling.
- f. Training of firefighters; adequacy of plans and procedures for responding to emergencies involving AE; the conduct of fire drills; and the availability and adequacy of fire fighting equipment, fire symbols, and chemical hazard symbols.
- g. Safety of material handling equipment.

### **1-11. Garrison or installation ammunition and explosive location maps**

Each garrison or installation shall maintain a map showing locations of AE. These maps shall be developed jointly by Garrison or Installation facility engineering or public works, plans and operations, safety, and logistics elements. The

Garrison or Installation Real Property Utilization Board will use this map when proposing new uses or changes in use of garrison or installation real estate. The garrison or installation explosives location map will include the following:

- a. AE hazard class and division and the NEW authorized at each site.
- b. AE safety 'clear zones' required around each location based on ESQD criteria.
- c. Primary and alternate routes for the transport of AE through the garrison or installation.
- d. Locations, outside of designated impact areas, authorized for the conduct of AE operations to include on- or off-loading, and combat aviation loading.
- e. Airfield locations designated for jettisoning or addressing hung AE and gun-clearing operations.
- f. Tracked vehicles upload and download areas (other than at authorized firing ranges).
- g. The AE support facilities, such as, AHAs.
- h. Locations of real property and facilities known or suspected to contain MEC, Material Presenting a Potential Explosive Hazard (MPPEH), and areas where a munitions response (cleanup) have been completed, but residual hazards are known or suspected to be present.
- i. Date the map was last validated.

### 1-12. Operational range safety

Commands with operational ranges shall establish a range safety program consistent with AR 385-63, DA Pam 385-63. (See table 1-2 below for location of DA Pam 385-64 tables.)

### 1-13. Certificates of risk acceptance

- a. Existing waivers will not be renewed, but will be replaced with a CORA if the condition for which the waiver was approved has not been corrected.
- b. Existing exemptions will be replaced with a CORA at their next scheduled review date if the condition for which the exemption was approved has not been corrected.
- c. The CORA will replace all waivers and exemptions by 1 October 2011.
- d. All explosives safety risk will be accepted at the appropriate level per DA Pam 385-30.

**Table 1-2**  
**List of explosives safety standard tables and locations**

Topic	Subtopic	Description	Table	Title
<b>Chemical</b>	Chemical	Type chemical agent (CA)/ hazard, chemical fire extinguishing precautions/actions, type clothing/equipment for chemical fire	6-3	Chemical hazard symbols and actions
	CA & chemical munitions	CA/fillers & hazard symbols in ammunition	6-7	CA and fillers contained in chemical munitions and the chemical hazard symbols required in storage
<b>Courses</b>	Safety Courses	Explosives safety courses	1-1	Army Explosives Safety Courses
<b>Distance</b>	Airfields	Distance for listed exposures	8-35	Quantity Distance (QD) application at airfields
	Exposed Site (ES)	Measuring distances from ES	8-5	Measuring Distance from ES
	ES Types	Distance, overpressure expected efforts, severities	8-6	Type of ES and Safe Separation Distance Required
	Maritime prepositioning ships (MPS)	QD requirements for maritime prepositioning ships	8-38	QD for MPS
	Port Facilities	QD requirements for various port facilities	8-39	Application of Port Facilities QD
	Safe Separation Distances and Severities	Distance, overpressure expected efforts, severities	8-2	Safe Separation Distances and Expected Severities
	Separation Distances for Ships, Piers, and Anchorages	Criteria for measuring separation distances to/from ships, piers, and anchorages	8-37	Measurement of Separation Distances for Ships, Piers, and Anchorages
	Ships	QD requirements for safe separation between ships	8-40	QD Separation of Ships
<b>Distances</b>	Airfield, assets preservation QD	Criteria for airfield PESs. Airfield (runways & taxiways) QD.	9-6	QD for asset preservation at airfields

**Table 1-2  
List of explosives safety standard tables and locations—Continued**

	Ammunition Pier QD	Ammunition pier separation distances	8-42	QD separations for pier and wharf facilities
	Armored Vehicles QD	QD for heavy, light, and armored vehicles	9-2	QD for armored vehicles
	BLAHA QD	BLAHA site separation distances. QD computations.	9-1	QD table for basic load ammunition holding areas
	Blast, overpressure	Required blast overpressure protection. Determine reduced blast distance for buried detonations.	8-34	Required blast overpressure protection distance in feet for nonessential personnel at ranges used for detonating ammunition for demilitarization, demonstration, or explosive ordnance disposal
	Conveyor systems	Safe separation distances on conveyor systems at maintenance lines.	F-1	Safe conveyor spacing
	Field storage & handling, QD	QD for field storage and handling areas	10-2	QD for field storage and handling areas
	Fragment Ranges	Case maximum fragment range for intentional detonation	8-32	Default case maximum fragment ranges for intentional detonations
	Fragment Ranges	Case maximum fragment range for simple item detonation	8-33	Maximum case fragment ranges for selected single item detonations
	Fragments and Firebrand	Application of fragment and firebrand distances	8-15	Examples of where minimum fragment distance or firebrand distance is required
	Fragments and Firebrand	Application of fragment and firebrand distances not required	8-16	Examples when minimum fragment and firebrand distances need not be applied
	Ground shock	Distance to protect against ground shock	11-3	Distance to protect against ground shock
	Hard rock debris	Distance to protect against hard rock debris	11-4	Distance to protect against hard rock debris
	HAS, Asset Preservation QD	QD for HAS and associated storage facilities	9-4	Minimum QD for hardened aircraft shelters for asset preservation
	HAS, propagation prevention QD	QD for HAS	9-3	Minimum hazard factor for hardened aircraft shelters (HAS) for propagation prevention
	HD Classes and Divisions	Description of the various hazard classes and divisions of AE	8-1	Classification of AE
	HD, Mixed NEW	NEW for mixed HD's	8-3	Mixing of hazard divisions for QD computations
	HD 1.1, Aircraft Parking, Mass/ non-mass detonating	HD 1.1 distance for military aircraft parking. Distance for mass detonating. Use for PTRD for non-mass detonating items.	8-36	HD 1.1 QD for military aircraft parking areas
	HD 1.1, Inhabited Building Distance (IBD) PTRD	Distances from IBD & PTR for HD 1.1	8-8	HD 1.1 IBD and PTRD
	HD 1.1, Hazardous Fragment Distance	NEW hazardous fragment distance	8-14	Hazard Division 1.1 Hazardous Fragment Distance
	HD 1.1, Hazardous Fragment Distance	Hazardous fragment distance for HD 1.1 open stacks	8-17	Hazardous Fragment Distances for open stacks of selected HD 1.1 items
	HD 1.1, Fragments	HD 1.1 Fragment distance unknown	8-18	Fragment unknown distance for HD 1.1
	HD 1.1, Intermagazine distances (IMD)	IMD for HD 1.1	8-11	HD 1.1 Guide for IMD
	HD 1.1, IMD factors	IMD hazard factors and distances for HD 1.1	8-12	HD 1.1 IMD hazard factors and distances
	HD 1.1, Intraline distance (ILD) other than earth-covered	ILD from potential explosion site (PES) (other than earth-covered magazine) for HD 1.1	8-9	HD 1.1 IMD from PESs other than earth-covered magazines

**Table 1–2**  
**List of explosives safety standard tables and locations—Continued**

	HD 1.1, ILD from earth-covered	ILD from earth-covered potential explosion site magazine for HD 1.1	8–10	HD 1.1 ILD from earth-covered magazines to the exposed site
	HD 1.1, QD	HD 1.1 QD minimum separation and preservation criteria	10–3	HD 1.1 QD requirements using minimum separation and asset preservation criteria
	HD 1.1 and 1.3, QD	External QD criteria, ground shock, debris, airblast, for HD 1.1 & 1.3	11–1	External QD determinations for HD 1.1 and 1.3
	HD 1.2, QD	HD 1.2 QD summary table	8–20	Summary of HD 1.2.1, 1.2.2, and 1.2.3 QD requirements
	HD 1.2, Subdivision Mixing	Mixing rule distances for HD 1.2	8–19	HD 1.2.1 IBD, 1.2.2, and 1.2.3 mixing rules
	HD 1.2.1, <1.60 pounds		8–21	HD 1.2.1 IBD, PTRD, and ILD QD
	HD 1.2.1, stored in structures	For items stored in structure which can contribute to debris hazard. Secondary fragment minimum distances.	8–22	Minimum fragment distances for HD 1.2.1 items stored in structures, which can contribute to the debris hazard
	HD 1.2.2, QD (IBD, PTRD, and ILD)	Stored in above ground facilities	8–23	HD 1.2.2 IBD, PTRD, and ILD QD
	HD 1.3, QD	QD for HD 1.3	8–24	HD 1.3 QD
	HD 1.4, QD	QD for HD 1.4	8–25	HD 1.4 QD
	HD 1.6, QD	QD for HD 1.6	8–26	QD criteria for HD 1.6 ammunition
	HD 1.6, QD	QD separations for HD 1.6	7–4	QD criteria for configuration of HD 1.6 components and assemblies with other HD components
	IBD air blast protection	IBD distances to protect against air blast	11–12	IBD distances to protect against air blast
	Maritime, Ships	Maritime prepositioning ships QD	8–41	Variation of MPS QD factors with load out
	Module Storage - Intermagazine separation, explosive to explosive	Minimum storage pad sizes. Minimum explosive to explosive distance. Barricade height based on storage pad size.	8–13	Intermagazine separation for barricaded storage modules for mass detonating explosives
	Ordnance sensitivity groups	Ordnance description/ compatibility groups	16–1	Sensitivity Groups
	Service tanks	QD for unprotected/above ground explosive service tanks	8–7	QD for unprotected above ground service tanks supporting explosives storage or operating complexes
	Soft rock debris	Distance to protect against soft rock debris	11–5	Distance to protect against soft rock debris
	Underground Storage - Chamber Separation	Underground chamber explosive loading densities	11–2	Chamber separation
	Underground Storage - Hydraulic Diameter	Effective Hydraulic Diameter	11–7	Values for Ratio DHYD/VE 1/2.8
	Underground Storage - IBD air blast protection vs. overpressure	Distances for IBD air blast protection versus overpressure	11–9	Distance versus overpressure along the centerline
	Underground Storage - IBD air blast protection w/o mitigation	Distances for IBD air blast protection	11–8	Scaled IBD for air blast without mitigating
	Underground Storage - Loading Density	Functions of loading density	11–6	Functions of loading density
	Unhardened exposed site, third-generation	QD for third-generation HAS's for HD 1.1 ammunition	9–5	QD from a U.S. third-generation hardened aircraft shelter potential explosion site to an unhardened exposed site
<b>EIDS</b>	EIDS ammunition	EIDS ammunition hazard classification/division	7–3	EIDS and EIDS ammunition hazard divisions

**Table 1-2**  
**List of explosives safety standard tables and locations—Continued**

<b>Electricity</b>	Earth electrode system	Ground rods, ground loop/ counterpoise, grid, radial, plates, Test probe C & P distances	B-1	Test probe C and P distances
	EEDs and transmitting antenna	Power density criteria.	17-3	Minimum safe distance from transmitter antennas
	Grounding	Lighting protection electrical test requirements for earth-covered magazines. Visual inspection procedures. Resistance value between equipment and earth electrode subsystem.	17-1	Grounding system inspection and test requirements
	Grounding rod	Ground rod quantity requirements	17-2	Ground rod quantity requirements
	Lightning Protection	Describes requirements for; materials to use, and how to maintain lightning protection system. Identifies type of conductors. Details on grounding. Bonding strap size and material requirements. Air terminal specifications and restrictions.	17-4	Lightning protection systems
<b>Energetic Liquid</b>	Compatibility	Classification, fuel storage hazard class and minimum QD	12-2	Hazard Classifications and Minimum QD for Energetic Liquids
	Compatibility Group	Energetic Liquid designation, definition and examples	12-1	Energetic Liquid Compatibility Group (ELCG)
	Convert gallons to pounds	Energetic Liquid, convert gallons to pounds at Fahrenheit temperatures	12-3	Factors to use when converting gallons of energetic liquids to pounds
	Explosive Equivalents	Determine equivalencies of energetic liquids mixtures at static test stands and range launch pads	12-4	Energetic Liquid Explosive Equivalents
	QD, for OSHA/NFPA Class I-III Flammable and Combustible Energetic Liquids	QD Criteria: OSHA/NFPA Class I-III with IBD/PTRD/ILD/ Aboveground IMD for storage in Detached Buildings or Tanks	12-5	QD Criteria for OSHA/NFPA Class I-III Flammable and combustible Energetic Liquids Storage in Detached Buildings or Tanks
	QD, Energetic Oxidizer	QD Criteria: NFPA Oxidizer Class with IBD/PTRD/ILD/ Aboveground IMD for storage in Detached Buildings or tanks	12-6	QD Criteria for Energetic Liquids Oxidizer (excluding Liquid Oxygen) Storage in Detached Buildings or Tanks
	QD, Liquid Oxygen	QD Criteria: IBD/PTRD with ILD/ Aboveground IMD	12-7	QD Criteria for Liquid Oxygen
	QD, Liquid Hydrogen/ Hydrazines	QD Criteria: Protected and Unprotected IBD/PTRD with ILD/ Aboveground IMD, Liquid Hydrogen/ Hydrazines	12-8	QD Criteria for Liquid Hydrogen and Bulk Quantities of Hydrazines
<b>Fire Prevention</b>	Extinguishing agents	Types of fires by class and their extinguishing agents	6-1	Extinguishing agents for fires
	Fire division symbols	Fire division symbols	6-6	Fire division symbols
	Fire divisions	Fire divisions	6-5	Fire divisions and associated hazards
	Fire hazards	Fire Hazards and firefighting guidelines	6-2	Fire symbol hazards and actions
	Fire protection withdrawal distances for nonessential personnel	Withdrawal distances for nonessential personnel	6-4	Emergency withdrawal distances for nonessential personnel
<b>General</b>	Explosive safety Tables	List and location of all DA Pam 385-64 Tables	1-2	List of Explosives safety Standard Tables and Locations
<b>Heat thermal</b>	Flux calculations	Heat/thermal flux	8-31	Thermal flux calculations
<b>MEC</b>	Explosive residue	Classification of operation and extent of explosive residue	19-1	Phase and extent of explosives residues
	Explosive residue	Explosive absorption based on type of material and explosive phase	19-2	Absorption of explosives as a function of type of material and phase of explosive

**Table 1–2**  
**List of explosives safety standard tables and locations—Continued**

	Site plan requirements for munitions of concern	Site plan requirements based on MEC activity	19–3	Explosives safety submission and ESQD site plan requirements for MEC activities
<b>Noise</b>	Impulse B-duration	Measure peak impulse noise B-duration	8–29	Impulse noise B-duration (estimate for various NEWs and distances)
	Impulse zones	Impulse noise zones	8–28	Impulse noise zones measured in feet from intentional detonations
	Impulse	Impulse noise protection	8–27	Impulse noise protection decision table
	Impulse protection, max detonations	Impulse noise zones. Noise zone required protection. Noise zone max detonations per/day	8–30	Impulse noise zones and required protections with maximum permissible number of detonations per day
<b>Over-pressure</b>	Opening	Effective overpressure at the opening	11–10	Effective overpressure at the opening
	Underground Storage - Overpressure, IBD	Allowable overpressure at IBD	11–11	Allowable overpressure at IBD
<b>Storage</b>	Ammo and Explosives	Storage compatibility groups of ammo and explosives	7–2	Storage Compatibility Mixing Chart
	Ammo and Explosives	Assigning of 13 Compatibility Groups	7–1	Storage Compatibility Groups
	Ammunition	Ammunition bulk storage compatibility	10–1	Wartime compatibility chart
	Captured Enemy Ammunition	QD for captured enemy ammunition	3–1	QD for captured enemy ammunition field storage and handling areas
	Storage and operations, non-DOD Explosive Operations	Non-DOD operations and storage of explosives on DOD installations	8–4	Criteria for Non-DOD Explosives Activities on U.S. Army garrisons or installations

## **Chapter 2**

### **General Safety**

#### **2–1. Imminent danger**

When an “imminent danger” situation is discovered, immediately cease operations, withdraw personnel from the hazard and immediately notify supervisor or activity head.

*a. Danger.* If the supervisor cannot immediately eliminate the hazard, the supervisor will notify the garrison or installation safety and occupational health official. The safety manager will provide technical advice to the on-scene supervisor, who will either correct the condition to allow affected operations to continue, or prohibit operations from proceeding and withdraw personnel from exposure. If the on-scene supervisor determines that any corrective action taken would not adequately mitigate the hazard, the supervisor will assess the risk and obtain the commander’s or an authorized representative’s approval to implement measures to mitigate the hazard and restart the operation.

*b. Unsafe act.* Anyone observing an unsafe act or condition may stop an operation and will immediately report it to a supervisor. Supervisors will halt any unsafe act and address any unsafe condition, ensuring documentation of the unsafe act or condition is provided to the safety office. Commanders may authorize other personnel to document an unsafe act or condition. Personnel who the commander may provide such authorization include, but may not be limited to the following:

*c. Safety, health, or fire inspector.*

- (1) The radiation protection officer.
- (2) Operators or team members responding to specific SOP instructions regarding identification and reaction to a hazardous, potentially hazardous condition, or defined quality defect.
- (3) Ammunition Surveillance/Quality Assurance Specialist (Ammunition Surveillance), GS–1910 Series, MOS 89B soldiers assigned as Ammunition Inspector in any Army organization, and wage grade Ammunition Inspectors (WG–6501 Series) and local national equivalents outside the continental United States (OCONUS) locations.

*d. Reporting explosives mishaps.* The AE accidents, incidents and mishaps shall be reported and investigated under AR 385–10 and DA Pam 385–40. Malfunctions must be reported per AR 75–1.

#### **2–2. Hazard analysis and risk assessment**

All operations involving AE will be reviewed to identify and manage the potential risk associated with the operation per DA Pam 385–30. Table 2–1 and figure 2–1 provide guides for determining risk levels for these activities.

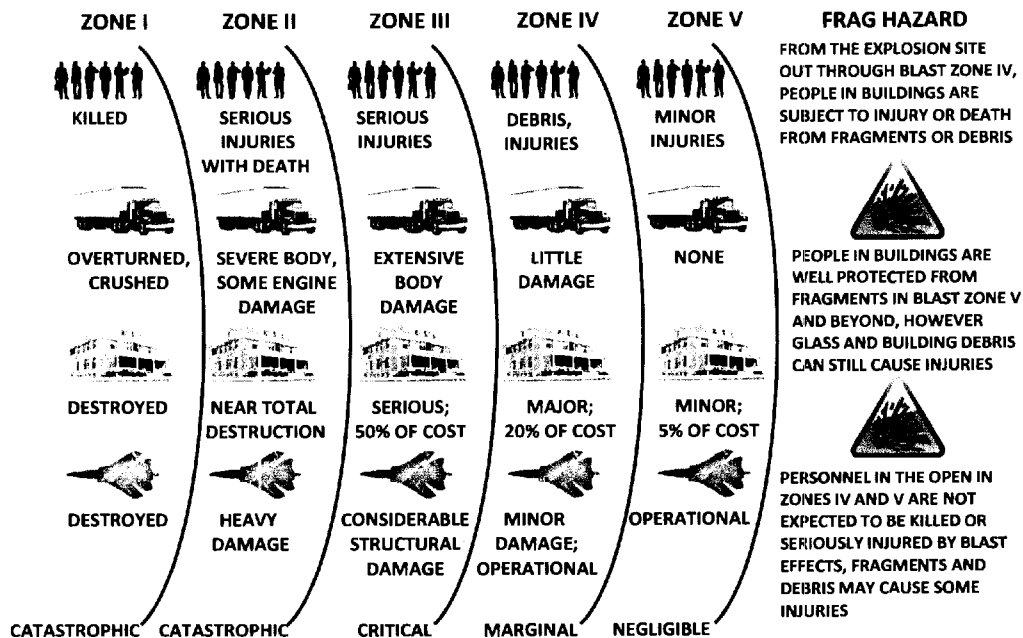

**Table 2-2**  
**Probabilities for common ammunition and explosive activities and environments**

Activity Type	Activity Environment						
	Operations in a hostile area	Unserviceable items awaiting destruction	Initial tests of new systems	Outdoors in inclement weather	Exercises, contingencies, Alerts	Flight lines	Missile systems
Assembly, Disassembly, LAP, maintenance, Renovation	L	NA	L	O	O	O	O
Demilitarization, Demolition, Disposal	L	L	U	O	O	NA	O
Training	L	NA	NA	S	O	S	S
Handling/loading	O	O	O	S	S	S	S
Transportation-break bulk	S	NA	NA	S	S	S	S
Transportation - containerized	U	NA	U	U	U	U	U
Inspection	U	NA	O	U	U	U	U
Storage	U	NA	U	U	U	U	U

Notes:

<sup>1</sup> L=Frequent/Likely, O=Occasional, S=Seldom, U=Unlikely, NA=Not Applicable



Legend for Figure 2-1;

ZONE I Barricaded Aboveground Magazine (AGM) Distance:  $6W^{1/3}$ ft ( $2.38Q^{1/3}$ m) - 27 psi (186.1kPa).

ZONE II Unbarricaded AGM Distance:  $11W^{1/3}$ ft ( $4.36Q^{1/3}$ m) - 8 psi (55.3 kPa).

ZONE III Unbarricaded ILD:  $18W^{1/3}$ ft ( $7.14Q^{1/3}$ M) - 3.5 psi (24 kPa).

ZONE IV Public Traffic Route Distance (PTRD) (under 100,000 lbs of high explosives (HE)):  $24W^{1/3}$ ft ( $9.52Q^{1/3}$ m) - 2.3 psi (15.8kPa).

ZONE V Inhabited Building Distance (IBD):  $40W^{1/3}$ ft -  $50W^{1/3}$ m) - 1.2 psi - 0.90 psi (8.3 kPa - 6.2 kPa)).

**Figure 2-1. Severity Chart: Blast and fragmentation effects to exposed sites/personnel**

### **2-3. Personnel qualifications**

Personnel working with AE will be trained in the tasks they are to perform. Such personnel must understand the risks, standards, procedures, and precautions that apply to their tasks. Each ACOM, ASCC, or DRU will establish a certification program that will include all personnel directing, supervising, planning, or performing AE-related functions (see table 1-1).

### **2-4. Use of written procedures**

Written procedures will be developed and used for each AE operation. The SOPs will be developed per AR 385-10 for all explosives operations to ensure workers have the information necessary to perform their assigned tasks safely. The SOPs for AE and related operations will identify potentially hazardous conditions. (See DA Pam 385-10, para 9-8 and TM 9-1300-250.)

### **2-5. Personnel and explosives limits**

Operations must be conducted in a manner that exposes the minimum number of people for the minimum period of time to the minimum amount of explosives required to perform a safe and efficient operations.

*a.* Personnel and explosives limits must be clearly posted in operating bays and readily available for all other operations and must not be exceeded during the operation. Explosives limits for AE operations will be included in the SOP.

*b.* Where concurrent operations must be performed in a single building, the layout will be planned to protect personnel from blast overpressure and provide for the separation of dissimilar explosives risks by using substantial dividing walls, barricades, or other means to provide the maximum protection allowed to personnel.

*c.* Nonessential personnel will be prohibited from visiting the site of operations. This restriction does not prohibit official visits by safety, quality control (QC), management, inspection or other personnel authorized by the commander. However, established personnel limits will be observed at all times.

*d.* Tasks not necessary to the AE operation will be conducted at an appropriate safe separation distance.

*e.* Each worker will be responsible for ensuring explosives limits for the work area are not exceeded. Limits will be expressed in total NEW, and/or by the number of munitions, trays, boxes, pallets, or other units that are easily determined and controlled.

*f.* Explosives limits, which will be based on the minimum quantity of AE required for the operation, will not exceed the quantity of AE required during half a work shift and consistent with QD separation criteria. When operational necessity requires, the commander may approve positioning of a greater quantity of AE through an approved Certificate of Risk Acceptance.

*g.* The maximum amount of AE of each hazard division (HD) allowed will be clearly posted in each room, cubicle, or building used for storage of AE. For operating locations, the explosives limits for each operation conducted will be clearly posted. Material limits need not be posted in AE storage magazines.

*h.* Organizations or individuals (such as, utility workers, farmers) not associated with explosives operations and their equipment may, when necessary, operate within an explosives areas without applying ESQD from a PES provided—

(1) The Army and the organization or individual have a signed contract, lease, agreement, or memorandum of understanding (MOU) permitting work within the ESQD arc of a PES.

(2) The Army and the organizations or individual have documented, assessed, and accepted, in writing, the potential risk associated with the operations being undertaken by both the Army and the organization or individual. Documentation will define the period of time and conditions under which access will be allowed and under which such access may be temporarily or permanently denied.

(3) The Army assesses the potential risks associated with access to the ES when any element (such as, operations performed, materials involved, hours of operation, nature of the activities conducted) of the PES or ES changes to determine whether continued access is appropriate.

(4) Equipment may be stored within the QD of a PES for an unlimited period of time provided it does not increase the risk of a fire or explosion at associated PES. The organization storing non-Army equipment at Army locations must accept, in writing, the risk of loss of or damage to the equipment should a fire/explosion occur.

### **2-6. Handling and movement precautions**

Personnel who handle AE will be trained to understand the potential hazards and risks associated with each operation. Supervisors will be trained to recognize and abate hazards associated with their operations. The precautions include:

*a.* Detonators, initiators, squibs, blasting caps (electrical and nonelectrical), and other initiating devices will be carried separately in protective containers. The containers must prevent item-to-item contact and be marked to identify the contents.

- b. Bale hooks will not be used to handle AE.
- c. Nails may be used to secure covers or repair AE containers only if there is minimal risk to the AE and to penetrating any protective coverings.
- d. Packing materials and procedures, including nails, will comply with technical packing orders, military specifications, or Department of Transportation (DOT) specifications applicable to the AE.
- e. AE containers will not be tumbled, dragged, dropped, thrown, rolled, or walked. Containers designed with skids may be pushed or pulled for positioning, unless otherwise marked on the container.
- f. Conveyors, chutes, hand trucks, and forklifts may be used, when appropriate, when where the circumstances allow and their use would not create additional risk.
- g. Sectionalized roller conveyors used to move AE will be supported with sections interlocked or secured. Boxes of AE will not be used to support conveyors.
- h. Only authorized and properly maintained tools, including hand tools, that are approved for use in locations having hazardous concentrations of flammable dusts, gases, vapors, or exposed explosives will be used. Safety hand tools will be constructed of non-sparking and/or spark-resistant materials (for example., wood, brass, titanium) that under normal conditions of use will not produce sparks.
  - (1) Hand tools or other implements used near hazardous materials must be handled carefully and kept clean. All tools will be checked for damage at the start and on completion of work.
  - (2) Ferrous metal hand tools may only be used when necessary for their strength. When used, the immediate area should be free from exposed explosives and other highly combustible materials, unless approved by the responsible commander or garrison safety officer.
  - (3) Safety hand tools containing copper or zinc (such as, brass, bronze) will not be used in proximity to lead azide or where residuals from the treatment of lead azide may be present.

## 2-7. Housekeeping

Ammunition AE storage, handling, and operating facilities and areas (AE facilities) will be maintained free of debris and rubbish, particularly the accumulation of oily rags or other material subject to spontaneous ignition.

### a. Waste materials.

(1) Waste materials (for example, oily rags) and hazardous materials (such as, explosives scrap) will not be mixed with wood, paper, and combustible packing materials. Each of these categories of waste will be carefully controlled and placed in separate approved, properly marked containers.

(a) With the exception of containers required to be within the area for operational requirements, waste containers will be placed outside the AE facilities, at authorized locations except for those containers required to be at the work location during operations.

(b) Working location containers required to be within the work area will be emptied as needed, but at least once each shift.

(2) Containers for explosive scrap will have covers, preferably self-closing; however, only approved containers, with covers, will be used for scrap black powder, self- initiating and scrap explosives of similar sensitivity, and rags contaminated with such explosives. These containers must contain enough water (No. 10 mineral oil or fuel oil for certain pyrotechnic, tracer, flare, and similar mixtures) to cover the scrap explosives or explosives contaminated rags.

(3) When water is used in containers for scrap pyrotechnic, flare, and similar mixtures, dangerous gases may be created and released. To minimize the hazards from these gases, such scrap will be placed in the container in a manner that provides immediate immersion.

(4) At a minimum, hazardous waste material will be removed from AE and other operating facilities and taken to an approved disposal area or temporary collection point at the end of each shift. More frequent intervals (for example, at each break) are encouraged.

(a) When isolated collection points are used, retention times and quantity limits will comply with environmental regulations and set up to ensure the timely movement of hazardous waste materials to the disposal area.

(b) Hazardous waste material should not be 'stored' in the disposal area, but disposed of as soon as possible after arrival.

(5) Hazardous wastes will be disposed of in authorized facilities. An SOP will cover disposal operations. The organization responsible for hazardous waste disposal will include a list of authorized disposal facilities on any waste disposal permits, as required by the Environmental Protection Agency (EPA).

b. *Cleaning.* A regular cleaning program will be established. To ensure safety, the frequency of cleaning, especially in operating buildings, will depend on local conditions.

(1) General cleaning will not be done during an explosives operation or while explosives are in AE facilities.

(2) Where there are exposed explosives or a risk from accumulating explosive substances (such as, dust), structural members, radiators, heating coils, pipes, electrical fixtures and similar equipment will be kept clean.

### c. *Sweeping compounds.*

(1) Sweeping compounds containing wax or oil will not be used on conductive floors.

(2) Cleaning agents that include caustic alkalis must not be used in locations containing exposed explosives because sensitive explosive compounds may form.

(3) Where there may be exposed explosives on the floor, hot water or steam is the preferred cleaning method.

(4) When sweeping compounds must be used, they will be nonabrasive.

(5) Sweeping compounds may be combustible, but will not be volatile (closed cup flashpoint will not be less than 230 degrees Fahrenheit).

(6) All loose explosives recovered as sweepings will be destroyed.

*d. Explosives recovery and reuse.* Explosives that are or have the potential to be contaminated with dirt, dust, grit, or metallic objects must be processed to remove all foreign matter before they can be reused, otherwise they will be destroyed.

## **2-8. Testing, disassembly, and modification of ammunition and explosive**

This paragraph identifies the precautions to be taken during testing, disassembly, and modification of AE.

*a.* Only qualified technicians will test, disassemble, renovate or conduct other modification of AE. Such actions will be performed according to approved SOPs. The supervisor will provide any necessary drawings and sketches.

*b.* Modification, testing, or disassembly of AE is only permitted when:

(1) Specifically authorized, with the approval of ACOM, ASCC, or DRU commander and the item manager or system program office;

(2) Conducted per approved publications; or

(3) Conducted as part of an approved organization mission that includes research, development, or test of AE or AE equipment.

*c.* Only EOD personnel, as defined in AR 75-15, may perform emergency render safe procedures.

*d.* When authorized, only EOD or other qualified personnel whose mission requires them to do so may disassemble unused- or rendered-safe munitions for the purpose of analysis, testing evaluation, assessment of capabilities and vulnerabilities.

*e.* When authorized, only EOD or other qualified personnel whose mission in support of foreign material exploitation (FME) Program requires them to do so may disassemble unused- or rendered-safe foreign munitions for the purpose of analysis, testing, evaluation, scientific and technical intelligence, assessment of capabilities and vulnerabilities in support of the FME Program as defined by DODD C-3325.1.

*f.* Operational shields, remote controlled devices, fire protection systems, and ventilator systems will be used where needed to protect personnel and property.

(1) Operations (for example, continuity checks of electrically actuated explosives devices, propellant cutting, explosives component assembly, modification, or disassembly and demilitarization) require proven operator protection.

(2) Operational shields and remote control systems will be designed based on the explosive material involved and tested to provide complete protection against any potential hazards (for example, blast, fragments, fire, heat, radiation, high-intensity light, toxic vapors) and will be approved for use.

(3) When protective devices of a specific design are required by:

*(a)* A technical manual (TM), the TM's proponent must ensure the devices have been tested and are safe.

*(b)* A using command, the command must ensure the devices have been tested and are safe.

*g.* The conversion of live AE to inert items may only be performed by explosive ordnance disposal (EOD) personnel authorized to inert such munitions. Inerting operations will be approved and documented per supply regulations. Additionally, inerted AE must be marked per MIL-STD-709C.

## **2-9. Explosive ordnance disposal training aids**

*a.* The EOD training aids are unique in their requirements for realism. The commander of each EOD unit having training aids will ensure EOD training aids are properly maintained.

*b.* No live AE will be mixed with training aids.

*c.* Training aids that are not small arms ammunition (SAA)—ammunition without projectiles that contain explosives (other than tracers), that is .50 caliber or smaller, or for shotguns—will be individually marked as inert. SAA may be marked by marking the container and the number of rounds contained in the box.

*d.* Individual training aids will be marked with a serial number; however, SAA containers may be marked instead of each SAA round.

*e.* EOD training aids will, as a minimum, be accounted for by the following:

(1) An annual 100 percent serial number inventory.

(2) A formal report of the results of the inventory.

(3) A file on record at EOD headquarters that shows by serial number and type where EOD training aids are located.

f. Prior to releasing an EOD training aid from its control, EOD will ensure the training aid complies with the requirements of paragraph 3–5 for marking inert AE.

## 2–10. Field safety

a. Force protection standards are based on physical criteria that do not change when AE is located in the field. In the event of an unintended detonation or initiation the same damages can be expected. During field logistics operations, protect friendly forces and equipment by implementing the standards of this pamphlet.

b. To the maximum extent possible, using units will ensure AE remains in its original packing or, upon being opened, is repacked per appropriate drawings or specifications, preferably using its original packaging material. This practice is critical to both safety and quality.

c. AE issued for training will remain packed until immediately prior to use, and then only the quantity expected to be immediately used will be unpackaged. Save all packing material until exercise is complete for possible use in for repacking.

(1) Replace all safety devices (such as, shorting clips on 2.75-inch rockets, electrical shunts on Hoffman devices, pads protecting primers on medium and large caliber AE) before repacking.

(2) Properly repack any open AE before transporting it on motor vehicles, aircraft, or watercraft.

(a) Verify and adjust, if required, quantities listed on packaging.

(b) Adjust inventory and certification document DD Form 836 (Dangerous Goods Shipping Paper/Declaration and Emergency Response Information for Hazardous Materials Transported by Government Vehicles), as required.

(3) AE that has misfired or has been classified as unserviceable must be indelibly marked (preferably using DD Form 1575 (Suspended Tag - Materiel)) and segregated from serviceable AE.

## 2–11. Rod and gun clubs

Each club that hand loads ammunition on Army property must operate according to written explosives safety standards. A qualified member will be designated to ensure explosives safety criteria are developed and enforced.

a. *Retail stores.* Where only retail sales are made, the facility will be managed and licensed similar to an Arms Room (see para 8–3).

(1) The garrison/installation commander, based on a risk assessment, may waive compliance with QD standards for reasonable quantities (for example, 100 pounds of propellant, 25,000 primers in their original shipping containers) of SAA.

(2) High explosive (HD) 1.3 propellant should only be placed in its original shipping containers. Use of other containers should be avoided when possible. Containers that could result in extreme confinement of gases should the propellant be ignited will not be used.

(3) When complying with paragraphs (1) and (2), above, an exception to QD and fire symbol requirements for HD 1.1 primers will apply. Fire symbol 3 may be used to designate the presence of propellant and primers. The symbol need not be changed during temporary periods when the propellant has been sold out, but primers are still in stock.

b. *Hand loading.* Hand loading operations will only be conducted in a room or building solely used for this purpose. In addition to the above requirements for retail stores, a written procedure that is approved by the garrison or installation safety office will be developed and posted. This procedure will, at a minimum, require that:

(1) Only authorized personnel who are trained in hand loading and knowledgeable about both safety provisions and the hazards involved will be allowed hand loading privileges. Reloaders will wear safety goggles or face shields. Trainees must be strictly supervised.

(2) Smoking, matches, or flame-producing devices will not be allowed in any loading room or building or associated storage locations.

(3) No more than 10 pounds of propellants; 10,000 primers, and 5,000 assembled rounds will be allowed in the hand loading room at one time.

(4) Storage lockers will be provided for the explosives per AR 190–11. Lockers will be locked when not in use.

(a) Only quantities required to sustain a continuous operation will be transferred to the loading point.

(b) Only one packing tray at a time will be removed from primer storage.

(c) Unused components will be repacked in their original containers and returned to the storage locker at the end of each loading operation.

(5) Good housekeeping practices will be observed at all times.

(6) Floors and walls must be free of cracks that could accumulate explosives dust and foreign materials.

(7) In case of a spill, all operations will stop until the explosives are cleaned up.

(a) Place all salvaged propellant in a metal container with water.

(b) All damaged components or damaged complete rounds will be placed in a separate, properly marked container.

(c) Salvaged propellant, damaged rounds or components, and empty explosives containers will be disposed of by qualified personnel.

(8) Only commercial-type loading tools, dies, scales, powder measures, and other equipment will be used during hand loading operations.

(9) Bullet molding will be done outside the hand loading room.

## **2-12. Public demonstrations, exhibitions, and celebrations**

*a.* Participation of Army personnel (military or civilian) in public demonstrations, exhibitions, or celebrations, including the shooting of motion pictures or Boss lifts, involving the use of military AE or other munitions (for example, commercial explosives, pyrotechnics) is not advisable, except in rare instances.

*b.* Requests for participation of Army personnel in such demonstrations, exhibitions, or celebrations either in an official or semi-official capacity, should be discouraged.

*c.* In the event such official participation is considered advisable, detailed plans for demonstrations, exhibitions, or celebrations involving Army personnel, activities, equipment, or materials will be submitted through safety channels to the ACOM, ASCC, or DRU commander for approval.

(1) Should demonstrations, exhibitions, or celebrations that involve Army personnel, activities, equipment, or materials be conducted on a host installation, the participating tenant organizations will submit a request through safety channels for its ACOM, ASCC, or DRU commander's approval and then submit the request to through the garrison's or host installation's safety channels for approval by the garrison or host installation's ACOM, ASCC, or DRU commander.

(2) Requests for participation shall include a risk assessment, operation plan specifying responsibilities and procedures to be followed, fire and medical support plans, and storage and control procedures for any AE, including commercial munitions to be used during the demonstration, exhibition, or celebration.

*d.* Commercial fireworks used in holiday celebrations on US Army garrisons or installations will be transported, set up, and, when possible, used on the same day. Only commercial firms or licensed pyrotechnic technicians will transport, set up, or use commercial fireworks. Such use will comply with local laws and National Fire Protection Association (NFPA) Standard 1123. When commercial fireworks or munitions of any kind are confiscated or found on a garrison or installation, an authorized official will request EOD support per AR 75-15.

## **2-13. Static or public display**

Live AE will not be used for display or loaded, or installed on display vehicles or aircraft. AE will not be rendered inert for this purpose, unless authorized by the item manager or the system program office. (See also paras 2-8, 3-5, and 3-6.)

*a.* Live and expended AE must be removed from gun systems on display. Operational vehicles and aircraft may be displayed without removing AE (for example, cartridge activated devices (CAD), propellant activated devices (PAD) from egress or life support systems); however, safety precautions will be taken per applicable technical manuals. Visitors will not be allowed near actuating controls.

*b.* When feasible, ejection cartridges will be removed from external release systems. If not removed, ensure that—

(1) Safety pins and devices are in place and cannot be easily removed

(2) Firing circuits are isolated (for example, circuit breakers are pulled).

*c.* Procedures for static display of vehicles and aircraft are contained in specific vehicle or aircraft technical manuals.

## **2-14. Explosives training aids for military working dogs**

The use of explosives training aids for training military working dogs is addressed in chapter 13 and AR 190-12 and DA Pam 190-12.

## **2-15. Outdoor recreational and cultural activities**

A garrison or installation commander may issue written permits authorizing outdoor recreational or cultural activities within areas where munitions (AE)-related activities (for example, live fire training or testing, demilitarization) have taken place based on a risk assessment, provided the activities can be controlled to ensure the safety of people and property. The exception are areas known or suspected to contain unexploded ordnance (UXO), as defined in Title 10, United States Code (USC) (10 USC 101(e)(5)) (see below).

*a.* When a commander authorizes access, based on a risk assessment—

(1) Maps and signage will clearly define the areas in which the activity may occur, routes to and from the area, and all areas to which access is prohibited.

(2) Participants will be thoroughly briefed on the potential hazards and actions to be taken in event they encounter or suspect they may have encountered a munition, the areas to which access is allowed and prohibited and any local requirements.

*b.* Authorized hunting will conform to applicable state, federal, or host nation regulations.

*c.* Installation and garrison commanders will—

(1) Prohibit unnecessary access (for example, livestock grazing; recreational uses, such as hunting and hiking) and

take appropriate action to deter unauthorized access to areas under their control that are known or suspected to contain UXO or other munitions (AE) (such as, discarded military munitions) that have experienced abnormal environments (for example, attempted demilitarization by detonation). Such areas should be indicated on real property records.

(2) Limit access to such areas, particularly operational range impact areas, to personnel who have an operational requirement to enter such areas (such as, range maintenance, environmental monitoring, security). A risk assessment to evaluate the potential hazards associated with the proposed activity shall be completed and methods to mitigate any potential exposures shall be implemented before allowing access.

(3) Take actions to prohibit or deter access that may include establishing access controls (for example, fencing the area, establishing roving security patrols) and providing public notifications (such as, posting UXO hazard warning signs, conducting UXO safety education programs) of any potential hazards. (When used, signs must be legible and, when appropriate, multilingual or pictograms.)

## **2-16. Unexploded ordnance safety education**

When areas that are known or suspected to contain UXO are present on Army installations, including installations affected by base realignment and closure (BRAC) or formerly used defense sites (FUDS), the installation, garrison or district commander will—

*a.* Provide UXO safety education training or information (such as, brochures) to people living on the installation or FUDS or that work on or use the property. Such training will be based on and incorporate the Army's 3Rs (Recognize, Retreat, Report) message and safety education material (available at <https://www.denix.osd.mil/uxosafety>). Such training will also be offered to schools on or in close proximity to the installation or FUDS on a periodic basis.

*b.* The local command will determine how this training will be provided. The U.S. Army provides UXO safety training and safety education that can be accessed at the Defense Environmental Network and Information Exchange Web site at <https://www.denix.osd.mil>. The installation, garrison or district safety office will ensure that coordination with Public Affairs and the appropriate support personnel is accomplished. EOD and other personnel with technical knowledge of UXO hazards may provide assistance.

## **2-17. Material handling equipment**

*a. General requirements.* Material handling equipment (MHE) (such as, forklift trucks, tow motors, powered pallet jacks, electric hand trucks) will be used in a safe and efficient manner per local MHE Licensing Program.

(1) Operators will be specifically trained on the unique requirements for and the hazards associated with handling AE.

(2) The operator will inspect MHE before use for unsafe conditions and current load test. Unsafe MHE and associated equipment (such as, lifting devices) will not be used until repairs are made.

(3) Safety devices (such as, dead-man switches) will not be defeated or circumvented.

(4) Forklifts will meet the requirements of applicable DOD and Occupational Safety and Health Administration (OSHA) standards. The garrison or installation commander may grant exceptions to the overhead guard requirement only when the height of the overhead guard would keep the forklift out of work locations or the overhead guard would be lower than the top of the operator's head.

(5) Operators will not use MHE to move loads that exceed the rated capacity of the MHE at the prescribed load-center.

(6) The MHE will be used only for its intended purpose (for example, forklifts will not be used as towing tractors).

(7) Containers and pallets will only be lifted only in an authorized manner.

*(a)* Items will be lifted using forklift pockets, if present.

*(b)* Items will be slung from lifting lugs/eyebolts, if present.

*(c)* Deviations from standard lifting procedures must be approved in writing.

(8) If multiple skids or pallets are to be lifted together, the items must be secured together to ensure the integrity of the lift.

*b. Battery-powered material handling equipment.*

(1) Battery-powered MHE is preferred for handling AE inside a building or a poorly ventilated area.

(2) Battery-powered equipment used within an explosives area will have all electrical cables mounted to prevent catching on stationary objects or damage by cutting or abrasion. Cables will be protected to prevent short-circuiting in as far as is practical.

(3) Batteries will be securely fastened. Battery boxes will provide ample ventilation, with ventilation openings that prevent access to the cell terminals from the outside.

(4) Battery-powered MHE must be equipped with a dead-man switch and a main service switch that can be activated from the driving position.

(5) Battery charging stations should be separated from AE facilities by the applicable distance (see chapter 8).

(6) The rated equipment defined in the National Fire and Protection Association (NFPA) 505, types E, EE, ES, and EX, are approved for use for handling all classes of AE packed per DOT regulations.

(a) Types EE and ES battery-powered MHE may be used for handling in-process AE (for example, sub-assemblies, explosives loaded components) in corridors or ramps connecting hazardous operations.

(b) Types EE and ES MHE will not be used in areas containing explosive dusts or with explosives that, through handling, may produce explosive dusts.

(c) Type EX MHE is the only MHE approved for use in areas with explosive dusts (NFPA 505). EX equipment does not carry a dual rating and can be used only in hazardous areas for which it is specifically designed.

(7) All battery-powered MHE will be provided with a fire extinguisher having a minimum rating of 5 BC (1-A: 10-B: C recommended).

*c. Gasoline and diesel powered equipment.*

(1) Gasoline and diesel powered MHE for handling inert materials will be equipped with backfire deflectors securely attached on the throat of the carburetor. These deflectors will be of the oil-bath or screen type. Certain types of air cleaners can serve as backfire deflectors. A tight fitting cap, properly vented, will be in place on the fuel fill pipe at all times except during refueling. A flame arrester will be installed in the fill pipe. If necessary, a deflector plate will be installed to prevent any overflow from the fuel tank from reaching the motor or the exhaust pipe. On gravity feed systems or on pump systems, where siphoning might occur, a shutoff valve will be installed at the fuel tank or in the feed line to permit shutting off the flow of fuel during an emergency or break in the fuel line or carburetor. Provisions will be made to protect against vibration rupturing the fuel lines.

(2) All MHE and any other gasoline and diesel powered equipment used in an AE area will be provided with a fire extinguisher having a minimum rating of 5BC (1-A: 10-B: C recommended).

(3) Gasoline and diesel-powered MHE and equipment should be checked before being put into operation to ensure sufficient fuel is available to minimize refueling requirements.

(4) Fueling of MHE and other gasoline and diesel powered equipment in an AE area will be done per paragraph 6-9e(6).

*d. Liquid petroleum-gas-powered equipment.*

(1) The LP-gas-powered MHE for handling inert material will be type LPS. All fuel lines, fittings, and containers will be designed and installed per NFPA Standard 58 to provide maximum protection against damage to the system by vibration, shock, or objects striking against it and against failures from other causes.

(2) All LP-gas-powered MHE and any other LP-gas-powered equipment used in AE area will be provided with a fire extinguisher having a minimum rating of 5BC (1-A: 10-B: C recommended).

(3) The LP-gas-powered MHE and any other LP-gas-powered equipment used in AE should be checked before operation to ensure all fuel lines, fittings, and containers are secure and that sufficient gas is available to reduce refueling or replacement of fuel containers.

*e. Gasoline, diesel-powered and liquid petroleum-gas-powered materiel handling equipment for handling ammunition and explosivesAE.*

(1) Gasoline, diesel-powered and LP-gas-powered MHE, with the precautionary measures and devices (see paras 2-17c and d above) are appropriate for handling all classes of AE packed per DOT regulations and provided the material is not located in a hazardous location as defined by the NFPA 70. The exterior of any packaging materials or exposed AE (such as, projectiles) must not be visibly contaminated with explosive residues nor have any explosives exposed.

(2) Due to the inherent hazards of operation, gasoline-powered or LP-gas-powered MHE are not recommended for use in Richmond or earth-covered magazines.

(3) Diesel-powered equipment may be used in Richmond and earth-covered magazines provided the concentrations of combustion products and noise emitted by the MHE meets the criteria established by OSHA and the Surgeon General.

*f. Materiel handling equipment storage.*

(1) Battery, gasoline, or diesel-powered MHE equipment may be stored in magazines, storehouses and other suitable locations designed for that purpose, are empty, or only contain inert materials.

(2) Stored MHE should be—

(3) At least 10 feet from any combustible material.

(4) Spaced to minimize the spread of fire from one unit to another, with aisles kept clear at all times .

(5) MHE essential for day-to-day operations may, when necessary, be parked in fire-resistant buildings containing AE , provided the below minimum requirements are met:

(a) The MHE must be stored in an area that is suitably and completely separated (by firewalls and closed doors) from the bays, rooms, or cubicles that contain AE.

(b) Designed fire-resistant ratings for the bays, rooms, or cubicles containing AE are not degraded.

(6) When necessary for efficient operation, battery-powered MHE is permitted to be used in buildings or magazines containing AE or other hazardous materials. Such MHE may be temporarily stored in magazines containing packaged AE and inert warehouses provided the following conditions (designed to prevent fires or other trouble from occurring during unattended periods) are met:



- (a) Periods of idle storage shall not exceed 4 days.
- (b) After each workday, MHE will be inspected for hot brakes, leaking oil, or fluid. If these are found, the MHE will be removed from the building.
- (c) MHE will be made inoperative by removing ignition keys, activating shutoff switches, or seat control disconnects, and so forth. Battery cables will not be disconnected in AE storage locations due to the possible arcing when terminals separate.
- (d) MHE will be parked and secured at the maximum distance allowed from AE.
- (e) MHE will not be stored in an operating building containing exposed explosives.

## **2-18. Amnesty**

a. Garrisons, installations, and forward operating bases having elements that use military munitions will establish an AE Amnesty Program. Commanders should establish their Amnesty Program using guidelines in keeping with their installation's mission. The AE Amnesty Program must—

(1) Address procedures for assisting and protecting the anonymity of personnel who turn-in AE under the Amnesty Program.

(2) Include an SOP that addresses—

(a) Functional responsibilities and qualifications of personnel that supervise, manage or support AE turned in or recovered under the AE Amnesty Program.

(b) The explosives safety requirements and hazards associated with handling AE that may be turned in under the Amnesty Program.

(3) Address provisions for EOD support.

(4) Advise personnel to follow the 3Rs (Recognize, Retreat, Report) when they encounter or suspect they may have encountered AE (munitions)

b. Military personnel assigned duties associated with AE will be briefed on the Amnesty Program at least once every 180 days and prior to operations, exercises or training events that provide access to or require the use of AE.

c. Army civilian, foreign national, and contract personnel assigned AE duties associated with AE at Ammunition Supply Points (ASP) will be briefed on the Amnesty Program semiannually.

d. All ASPs will provide amnesty collection points that are available 24 hours a day, 7 days a week.

e. ASP amnesty collection containers will be checked and cleared regularly and as necessary to prevent excessive accumulation of explosives to reduce the risk to personnel.

f. The AE-recovered through the amnesty program will be inspected by qualified DOD personnel (for example, EOD, QASAS) to determine whether it is safe to handle and can be returned to the logistics system for issue. Other personnel (such as, explosives workers) assigned to perform these duties must be designated in writing by the garrison or installation commander.

g. AE amnesty collection points will not require explosives safety site plans; however, a risk assessment, using the mishap risk management process of DA Pam 385-30, is required. The installation fire department must be informed of amnesty collection points or containers.

h. Amnesty containers.

(1) Amnesty containers in the Ammunition Peculiar Equipment (APE) catalog is available at the Joint Munitions Command (JMC) APE Web site <https://www4.osc.army.mil/apecat/> by searching for "amnesty container" under Non Standard APE. Contact the APE Program Office (JMC, AMSJM-LID), 1 Rock Island Arsenal, Rock Island, IL 61299-600, or e-mail at [rock-amsjm-lid@conus.army.mil](mailto:rock-amsjm-lid@conus.army.mil) for availability of nonstandard or standard amnesty containers, designs, and drawings, or additional information.)

(2) Locally designed and approved amnesty containers that meet the below requirements are authorized for use.

(3) Amnesty containers must be placed in accessible low risk areas and marked with a contact phone number that is available 24 hours a day, 7 days a week.

(4) Amnesty containers for SAA only are authorized for use in densely populated areas.

(5) Although amnesty containers are not designed nor expected to contain an explosion, they should, to the maximum extent practicable—

(a) Prevent unauthorized removal of AE.

(b) Prevent unauthorized removal of the amnesty container.

(c) Provide protection from weather exposure (such as, rain, sleet, and snow).

(d) Prevent AE from accumulating, dropping or falling in such a way that might cause inadvertent initiation.

## Chapter 3 Principles of Ammunition and Explosive Storage

### 3-1. General requirements

This chapter sets forth the requirements for storage of AE within the U.S. Army. AE should be stored in buildings designed, designated, and isolated for this purpose. (See para 8-3 for requirements for storing AE in arms rooms.)

*a.* When standard magazines are not available, buildings used for AE storage must afford protection against moisture and excessive changes in temperature and have means for adequate ventilation. The floors will not be wood or of a material that would produce dust. In structures where heat is permissible, only authorized heating equipment, as specified by the building safety submission, will be used (see chap 4). Open fires or heating by stoves is not permitted. The buildings are not to be used for any other purpose when AE is present. AE (except limited quantities of SAA) will not normally be stored in basements, attics, or other portions of barracks, company supply rooms, general storehouses, or any buildings being used for other purposes.

*b.* The AE will be stacked by lot number in stacks and arranged so that air may circulate freely beneath and throughout the stack. When multiple lots are stored, all items or containers of a single lot should be stored together and the line of separation between lots must be clearly indicated with a DA Form 3020-R (Magazine Data Card), equivalent marking, or physical separation. Lots of AE must never be mixed randomly. Except in earth-covered magazines, tops of AE stacks will be below the level of the eaves, but no closer than 18 inches to the roof to avoid the heated space directly below the roof. In earth-covered magazines, AE will not touch the ceiling or sides of the earth-covered magazine. In heated warehouses or other buildings, AE stacks will not be closer than 18 inches to radiators or heaters. The bottom layer should be raised from the floor about 3 inches. Stacks must be level; if necessary, dunnage, shims, or wedges will be used to prevent the stacks from tipping. Stacks will not be so high that AE or AE containers in the lower layers will be crushed or deformed.

*c.* Boxes, cases, and other containers of AE should be clean and dry before being stored. AE containers will not be opened in a magazine (except as detailed in paras 3-2*i* and 9-9*e*). AE containers should not be stored after having been opened unless securely closed. The exception is that damaged containers in the process of being repaired may be stored overnight in magazines. When it is necessary to store AE overnight in damaged containers, such containers should be separated from serviceable containers of AE. Repair or change of AE containers can be accomplished at intraline distance (ILD) (minimum distance of 100 feet from combustible storage structures or 50 feet from noncombustible structures) from the magazine based on the quantity of AE at the repair or change site. Magazine doors will be kept closed during such work.

*d.* Unpackaged rounds or components will not be kept loose in a magazine containing other AE packed per approved drawings. Empty containers, excess dunnage, or tools should be permitted to remain in a magazine only during the period of time required to complete the job for which they are being used. No oily rags, paint, and other flammable materials will be present in magazine containing AE.

*e.* Liquid propellants, flammable liquids, and gases, corrosives, and oxidizers will not be stored with AE. Nonflammable gas; for example, argon, can be stored in the same storage structure with the AE it supports. When the nonflammable gas is stored with the AE, valves must be protected from inadvertent impact or packed in approved DOT containers.

*f.* Lethal and incapacitating chemical munitions and agents (chemical surety material) must be stored separately from conventional AE, including AE with nonlethal or incapacitating chemical fills (for example, FS smoke). Chemical munitions storage should be planned so containers of bulk agent and individual munitions can be inspected for leaks and easily removed. Additional information concerning chemical munitions and agents are contained in paragraphs 3-26, 4-1, 7-4, 7-5, and figure 6-3.

*g.* The AE containing explosives or combustibles (such as, black powder, tracer composition, or pyrotechnic mixtures) that deteriorate rapidly in damp or high temperature environments should be stored under the best cover available. Buildings that protect against dampness and have adequate ventilation are preferable.

*h.* The amount of necessary combustible materials (dunnage, pallets) used in magazines will be kept to the minimum essential.

*i.* When a magazine becomes empty, the following procedures will be followed:

(1) When the last AE is removed from a magazine, the magazine will be inspected. An empty magazine need not be inspected before being reused for storage provided that—

(*a*) It was inspected after it was emptied.

(*b*) Magazines and storage formerly used to store chemical surety material have been certified free of toxic hazard.

(*c*) All defects noted during the inspection have been verified as being corrected.

(2) Empty magazines must be sealed with a numbered seal to ensure that AE is not stored without proper notification of the AE security, and surveillance organizations. Local procedures must ensure notification. Integrity of the seals will be assured at least every 12 months.

(3) Empty magazines at garrisons or installations that have been selected for base closure will no longer be used for storage of DOD AE. Once inspected, certified empty, and sealed with a numbered seal, these magazines will no longer

require visual inspections or electrical testing for the lightning protection and grounding systems. All required inspections and electrical tests must be performed before reuse.

(4) Fire symbols and chemical hazard symbols will be removed or covered.

### 3-2. Magazine storage of ammunition and explosive

*a. Magazines and magazine areas.* A segregated area will be set aside to store only AE. Magazines or open revetted sites in the magazine area may be used for storing AE-related inert items.

*b. New storage magazines.* DDESB Technical Paper No. 15 (TP-15) provides a listing of 7-bar and 3-bar structures approved for new construction. The U.S. Army Corps of Engineers (USACE), Huntsville Center has plans and specifications for earth-covered magazines and other structures approved for new construction.

*c. Magazines.*

(1) *Earth-covered magazines.* This group includes reinforced concrete-oval arch, Stradley igloo, steel semicircular-arch type, hillside, and subsurface-type magazines. Earth-covered magazines are preferred for the storage of all AE requiring special protection for safety and/or security.

(2) *Standard AE magazines (commonly called standard magazines), classed as aboveground magazines.* These magazines were designed to store fixed rounds or separate loading projectiles. For future use, such magazines should be restricted to storing HD 1.2, 1.3, and 1.4 materials (excluding rockets and rocket motors). The storage capacity of the magazines is not stated in definite figures because the number of items that can be stored is regulated by the appropriate QD tables.

(3) *High explosives and black powder magazines, classed as aboveground magazines.* These magazines were designed to store bulk explosives, such as black powder, TNT, Tetryl, and Explosive D and may be used for this purpose if more desirable storage space cannot be obtained.

(4) *Primer and fuze-type magazines, classed as aboveground magazines.* These magazines were designated for storing primers, primer detonators, adapters and boosters, and fuzes of all types. When it is necessary to use magazines of this type, they should be restricted to storing Classes/Divisions 1.2.2, 1.3 (except rockets and rocket motors), and 1.4 AE.

(5) *Service magazines and service storage buildings.* These buildings are used for temporary storage of the minimum amount of AE necessary for safe and efficient processing operations at an associated AE operation. Construction details of such magazines vary, depending upon local circumstances. However, consideration should be given to using fire-resistant materials and/or fire-resistive construction.

*d. Preferred magazine usage for ammunition and explosive storage.* The AE stored in earth-covered magazines are better protected from external sources of initiation than items in aboveground magazines. Earth-covered magazines also provide better temperature control than aboveground magazines and are particularly desirable for storing solid propellants and pyrotechnics.

*e. Temperature control.*

(1) Sudden changes in temperature may damage airtight containers or may result in excessive condensation. If the ambient temperature in an aboveground magazine exceeds 100 degrees F for a period of more than 24 hours, the magazine should be cooled by wetting the exterior of the building with water and by opening the doors and ventilators after sunset and closing them in the morning. If these methods do not effectively lower the temperature, the commander will decide whether the materials should be removed to some other magazine.

(2) Storage magazines in general should not be heated. An exception is made in the case of magazines where heating may be necessary to prevent condensation of moisture, to maintain constant temperature, or other reasons. Where a suitable heating apparatus is used to heat a magazine, it must be arranged so that AE is kept at least 18 inches from the heating element.

*f. Magazine operational requirements.* The following requirements will be met wherever AE are stored:

(1) Loose AE (munitions) components, packing materials, conveyors, forklifts, skids, dunnage, empty boxes, and other similar material will not be stored in a magazine containing AE.

(2) Vegetation around all AE storage locations will be controlled to minimize fire hazards. (See chap 6, Controlled Burning.)

(3) Workers must have an unimpeded path to an exit. When personnel are working in magazines or structures having:

(a) More than one door, at least two doors must be unlocked and ajar.

(b) A single entrance with double doors, both doors must be ajar.

(c) A single entrance with two jack-up style doors, only one door must be open.

*g. Stacking.*

(1) AE will be stored in containers as prescribed by approved drawings and specifications and should be stacked and arranged in a magazine per approved drawings listed in U.S. Army Material Command (AMC) Drawing 19-48-75-5. AE in stacks will be grouped and identified by lots. The general rules in (2) and (3), below, should be followed in the absence of applicable storage drawings or when operational necessity prevents adherence to such drawings.

(2) Methods used for stacking must provide ventilation to all parts of the stack. Adequate dunnage will be used, when necessary, for this purpose.

(3) Aisles will be maintained so that AE in each stack may be inspected, inventoried, and removed for shipment or surveillance test. To allow personnel to escape quickly in emergency situations, aisles will not be obstructed.

(4) The AE returned from users without proper packaging should be repackaged per approved drawings and specifications prior to storage.

*h. Unpackaged ammunition and explosives; damaged, incomplete, and opened containers of ammunition and explosives.* Unpackaged AE (such as, loose rounds) or single fiber containers of AE will not be stored in magazines containing AE that are packed per approved drawings. Unpackaged AE may be stored in structures set aside exclusively for such storage. Incomplete boxes of AE may be stored in magazines containing AE packed per approved drawings. Incomplete boxes of AE, which must be clearly marked to identify the content and quantity of AE, will be stored in designated locations within a magazine. AE in damaged containers will not be stored in a magazine with AE in serviceable containers (see para 3-1c for exceptions). Such containers will be repaired or the contents transferred to new or serviceable containers. Open containers of AE and containers of AE with covers that do not securely fasten will not be stored in magazines except for material in service magazines for which a hazard analysis has verified that the storage configuration does not decrease safety, consistent with security requirements. (See chap 9 for guidance on combat load storage.)

*i. Operations permitted in magazines containing ammunition and explosives.* Operations that are incident to storage, inspection, inventory, or shipping are permissible inside a magazine. The presence or absence of an environmental shelter at the magazine does not alter the scope of the following permitted operations. The below operations are permitted within a magazine provided space is available and a rapid egress route is available. Otherwise they should be performed outside a magazine or on an adjacent apron.

(1) Palletizing and replacement of defective banding.

(2) Removal and replacement of shipping bands on bombs.

(3) Removal and replacement of grommets on separate loading projectiles.

(4) Removal of bomb and projectile plugs for inspection of fuze cavities, cavity liners, and threads.

(a) Do not apply undue force during any phase of a plug removal operation.

(b) The only acceptable plug removal tool is a torque wrench designed to break away at excessive torque levels.

(c) Prior to removing a plug, the exterior surface of the projectile or bomb must receive a thorough (360 degrees) visual inspection for signs of exposed explosives or explosive residues. Loosening or removal of plugs is not permitted where there is evidence of exposed explosives in the threads or cavities in the form of dust, spillage, or exuding explosives.

(d) When exposed explosives or explosive residues are encountered, plug removal must be done in a designated maintenance area per a local SOP.

(e) When there are no exposed explosives or explosive residues in the threads or cavities, the projectile or bomb may be cleaned and preservatives applied.

*Note.* Power driven tools, highly flammable or toxic solvents, or ferrous brushes will not be used for this purpose.

(f) Plugs will be removed from the magazine for cleaning.

(5) Marking of containers:

(a) No open containers of flammable liquids are permitted within a magazine or in close proximity to AE.

(b) Use of minimum essential quantities of flammable liquids is allowed outside of the magazine.

(6) Air test of propelling charge containers (see para 15-5.)

(7) Outer containers of AE may be opened in storage locations for inventory or desiccant change-out provided access to the AE is precluded; however, AE containers will not be opened within a storage location for issuing AE.

(8) For magazines that only store HD 1.4, preservation, packaging, unpacking, inspecting, and repackaging is allowed, provided there is sufficient room in the magazine and normal precautions are taken.

(9) Operations incident to liquid level determination using a probe sensor, ultrasonic device or x-ray device.

(10) Operations incident to visual inspection and inventory of HD 1.4 AE. HD 1.1, 1.2, and 1.3 may be visually inspected on the magazine apron or in an approved shelter, if disassembly that would expose explosives is not required, the AE does not contain electrically initiated components, the AE does not contain its own means of initiation, and no testing of the AE is required.

*Note.* AE requiring fire division symbol 1, 2, or 3, regardless of hazard division, may not be unpackaged in magazines.

(11) Operations incident to visual inspection of the exterior packaging of separately packed propelling charges and bulk solid propellants.

(12) Removal of storage container lids for the visual inspection of cluster bomb units (CBUs)/container units (CNU)s).

(13) Operations incident to the electronic retrieval of surveillance/telemetry data from missile items provided for in the appropriate technical documentation for the missile system.

*j. Operations permitted between magazines.* Inspection and repair may be done in the open provided the following separation distances are maintained:

(1) At least 100 feet or ILD, whichever is greater, from aboveground magazines and the unbarricaded door end of earth-covered magazines.

(2) At least 50 feet or intermagazine distance (IMD), whichever is greater from the sides and rear of earth-covered magazines. This distance will be based on the quantity of AE involved in the operation.

(3) Operations incident to the inspection of separately packed propelling charges and bulk solid propellants.

(4) Operations conducted outside of reduced quantity-distance magazines will be per the latest DDESB guidance for the specific magazine.

(5) Loading and unloading of shipping conveyances are permitted for AE stored in that magazine. Loaded conveyances will be removed as soon as practical, but not to exceed 24-hours.

*k. Protection from moisture or excessive heat.* AE, particularly pyrotechnics, solid propellants, and propelling charges, are adversely affected by dampness and extreme heat. Storage drawings in AMC Drawing 19-48-75-5 provide stacking schemes that should provide adequate ventilation.

*l. Repairs to magazines.*

(1) Magazines will not be repaired until prevailing deficiencies have been evaluated and it has been decided whether the contents must first to be removed. Under no circumstances will repairs be made to the interior of magazines containing bulk explosives. Under normal conditions roofs, ventilators, lightning rods, doors, and other parts of or appendages to the exteriors of magazines containing bulk explosives may be repaired without first removing the explosives. In addition to repairs of this type, minor repairs may be made to the interior of magazines containing finished AE or AE components.

(2) When magazines are repaired, the general safety requirements of this pamphlet are mandatory, particularly those relating to eliminating fire risks. The following special requirements are also applicable:

(a) All work will be done by trained and qualified personnel.

(b) The floor in the immediate vicinity of the repair must be thoroughly cleaned.

(c) Work requiring soldering, the melting of asphalt, or using flame or any heat-producing equipment at a magazine containing AE requires a hot work permit (see para 6-8). Such work will only be done after a risk assessment has been completed and approved, and any mitigating controls determined necessary have been put in place.

(d) Magazines in which repair work has been done will be inspected by authorized personnel (for example, facilities engineers) once the work is completed.

(3) When the commander authorizes the use of heat-producing items (for example, melting pots, lighters) in an AE storage area, the equipment will be kept at least 90 feet from any AE. When necessary, baffles and screens will be used to confine sparks and flames.

*m. Telephones in magazine areas.* Telephone communication should be provided in AE magazine storage areas. Telephones located outdoors should be protected from the weather.

### **3-3. Outdoor storage**

*a.* Outdoor storage of AE should only be used as an emergency expedient. When magazine storage is not available, every effort should be made to provide covered storage.

*b.* When used, outdoor storage sites will be separated from magazines, other facilities, and each other per the QD requirements of chapter 8.

*c.* Outdoor storage sites will be level, well-drained, and free from readily ignitable and flammable materials. The supporting timbers or platform upon which AE is stored will be well constructed to prevent AE from falling, sagging, or shifting. Steel dunnage should be used where practicable. To ensure stack stability and free circulation of air, not less than 3 inches of dunnage should be used between the bottom of the stack and the earth floor. Fire-resistant, waterproof overhead covers should be provided for all AE. An air space of not less than 18 inches should be maintained between the top of the AE stack and the cover. Sides of covered AE stacks also may be protected by nonflammable or fire-resistant covers provided a minimum of three inches clearance is maintained on all sides of stacks for ventilation.

*d.* Frequent inspections will be made to detect unstable stacks and accumulations of trash between or under stacks.

*e.* Excess dunnage should not be stored between outdoor sites and magazines nor between magazines. Excess dunnage storage sites should comply with applicable QD requirements, except that during outdoor storage operations, service supplies of dunnage may be located not closer than 50 feet from the stack being processed.

*f.* Suitable types of firefighting equipment and symbols should be provided. Fire Department personnel should be used to assist in the determining of type, size, and placement of equipment.

### **3-4. Storage of specific types of ammunition and explosive**

*a. Improved conventional munitions.* Submunitions may become armed and sensitive to initiation if ejected from an

ICM. Emphasis will be given to blast and fragment mitigation and prevention of ejection of submunitions in layout plans, process equipment and operations, storage, disposal, and other associated accident prevention considerations.

*b. Black powder.*

(1) Black powder in bulk should be stored in dry magazines. Black powder will not be handled or stored in inhabited buildings, general supply rooms, or any building heated by stoves or open fires.

(2) Magazines storing black powder should have conductive floors.

(3) Safety conductive (non-sparking) shoes will be worn in a magazine containing black powder.

(4) The only work allowed in magazines storing black powder is storage operations and the cleanup of spilled grains of black powder.

(5) Conductive nonferrous nonmetallic mats will be used at locations where operations such as repacking black powder are performed.

(6) Containers of saluting, practice, and smoke-puff charges will be stored with tops up.

(7) Containers of black powder will be carefully examined at the time of receipt for weak spots and holes, with special attention to looking for small holes, such as nail punctures that are not immediately evident.

(8) Damaged black powder containers will not be repaired; instead their contents will be transferred to serviceable containers.

(9) If any black powder is spilled, work will stop until the spillage is carefully taken up and the spot washed with water. The powder taken up will be destroyed by dumping in water and later disposal by appropriate methods.

*c. Military dynamite.* Military dynamite, M1, which provides a medium velocity blasting explosive in military construction, quarrying, and demolition work, should be used in lieu of 60 percent commercial dynamite whenever possible. Unlike commercial dynamite, military dynamite does not contain nitroglycerin and will not freeze in cold or exude in hot weather. Its composition does not absorb or retain moisture. Additionally, its shipping containers do not require turning in storage and safety in transport, storage, and handling is better than that of commercial dynamite.

*d. Storage of bulk initiating explosives.* Bulk initiating explosives must be stored alone or with similar compatible compounds. Such bulk explosives must not be stored dry and will not be exposed to the direct rays of the sun. If long-term storage in shipping containers is contemplated, the container must be equipped with a cover having a port for observation of the level of liquid therein. The viewing port must be covered with a transparent plastic which is known to be compatible with the initiating explosive being stored. When mission essential, bulk-initiating explosives may be stored in shipping containers that are not so equipped, provided they are stored in frost proof, earth-covered magazines with containers on end, only one tier high, and with passageways for inspection and handling. Bags of initiating explosives in storage containers must be under distilled water. Alcohol may be added to the distilled water to prevent freezing.

*e. Bulk solid propellant and separate loading propelling charges.*

(1) Propellant should be stored in magazines that are well ventilated and dry.

(2) Containers should be stored so the cover can be readily inspected or removed so that containers may be air-tested in storage.

(3) Bulk solid propellant and separate-loading charges are packed in airtight containers for storage. It is important that containers remain airtight until the propellant is used. When damaged or leaking containers are discovered, an examination of the contents will be made for the nitrous/nitric odor of decomposing propellant. If any such conditions are observed, the propellant will be segregated, reported, and disposed of per National Inventory Control Point (NICP) instructions. Propellants and propelling charges in containers should be stored so that it can be readily inspected. Only the minimum number of containers will be opened and then, only for the shortest period of time consistent with safe and efficient operations. Containers of bulk solid propellant and separate-loading charges will not be exposed to the direct rays of the sun. When a shipment is received, every pallet load will be given a visual inspection to ensure that it is not damaged.

(4) Metal containers for propelling charges are fitted with a test hole in the cover to allow testing for air tightness after the containers have been opened and closed. Motor-driven air compressors will not be taken into a magazine in which AE are stored. If a compressor is driven by a gasoline motor, the motor should be placed no closer than 50 feet to the magazine or to any explosive material. An electrically continuous path to ground will be maintained between the supply tank and container being tested. The entire system will be grounded prior to testing.

(5) The normal odor in a solid propellant magazine is a faint odor of alcohol-ether. If this odor is strong, it probably indicates a leaky container. Every leaking container will be repaired or the contents transferred to an airtight container. If the contents of any container show evidence of dampness or moisture, it should be segregated and reported. Leaks due to defective covers or gaskets may be repaired without removing the charge from the container or the container from the magazine, provided care is taken to guard against sparks. Repair of leaks in other parts of the container will be undertaken only after the charge is removed from the container and the container from the magazine. Containers found unserviceable should have the charge removed and placed into an appropriately marked serviceable container. The empty, unserviceable container must be tagged and may be left in the stack until time of the shipment or returned to storage. No other repair operations on solid propellants or propelling charge containers will be permitted in a magazine containing AE.

(6) Personnel engaged in air-testing must be familiar with the odor and appearance of decomposing propellant. The odor of decomposing propellant is so characteristic that it cannot be mistaken for the normally present odor of alcohol-ether. Personnel engaged in air-testing should examine each container opened for an air test for the presence of the acrid odor of nitrous/nitric fumes instead of the characteristic odor of alcohol-ether. The odor of nitrous/nitric fumes is one of the first evidences of dangerous deterioration.

(7) Some fine grain solid propellants having high percentages of nitroglycerin are almost as sensitive as black powder, and the same precautions will be observed. Inspection schedules must be maintained to ensure that deterioration will be detected in the early stages.

*f. Separate-loading projectiles.*

(1) Steel dunnage is preferred to wood; and, for storage in other than earth-covered magazines, steel dunnage should be connected by electrical conductors and grounded. If it is necessary to use wood for dunnage, the amount should be kept to an absolute minimum. Unfuzed projectiles will be fitted with eyebolt lifting plugs. If it is necessary to move a fuzed projectile, it will not be rolled.

(2) Palletized projectiles will be stacked per approved drawings.

(3) Projectiles containing ICMs will have a fusible lifting plug.

*g. Pyrotechnics.* Pyrotechnics require protection against moisture, dampness, and high temperature. Pyrotechnic AE must be given high priority for the best available protection because of its sensitivity. Pyrotechnic material that has been wet is hazardous to store; consequently, any boxes that show signs of dampness will be removed from a storage site and inspected. If the pyrotechnic material is wet, it will be destroyed. Certain kinds of this material deteriorate with age and have an expiration date on the containers. Loose pyrotechnic tracer composition, flare composition, and similar mixtures that have spilled from broken containers should be carefully taken up and covered completely with SAE 10 (EO-10) engine oil and removed for appropriate disposal.

*h. Shaped charges.* Shaped charges focus blast effect into a directional jet, resulting in greater penetrating ability than an equivalent sized unfocused charge. Because of this directional effect, special storage considerations apply.

(1) When packaging and storage criteria allow, shaped charges will be pointed toward the floor. When this is not possible, shaped charges should be pointed toward an exterior wall. In an earth-covered magazine, shaped charges should face the side or rear walls.

(2) Shaped charges should not be pointed at any wall at which AE is stored on the opposite side, such as in a multicubicle magazine.

*i. Rockets, rocket motors, and missiles.*

(1) Rockets, rocket motors, and missiles should be stored out of the direct sunlight in a dry cool magazine or other locations where temperatures would not exceed 120 degrees Fahrenheit. Prolonged exposure of rockets, rocket motors, and missiles to either high or low temperatures may increase the normal rate of deterioration or render the motors more susceptible to ignition if subsequently handled improperly.

(2) Specific storage requirements apply when rockets, rocket motors, and missiles are stored in a propulsive state.

*(a) Earth-covered magazines.* This is the preferred mode of storage. Refer to the approved storage drawing (AMC Drawing 19-48-75-5) for orientation of rockets, rocket motors, and missiles. Small rockets and missiles may be stored without regard to direction in which they are pointed, except that they will not be pointed upward or toward the door or headwall.

*(b) Aboveground storage structures.* This is an allowable substitute storage mode when earth-covered structures are not available. Orient rockets, rocket motors, and missiles in the direction that presents the least exposure to personnel and property or toward strong artificial or natural barriers.

*(c) All storage.* If allowed by approved storage drawings (AMC Drawing 19-48-75-5), propulsive items should be stored pointed down.

(3) Rockets, rocket motors, and missile that are not in a propulsive state may be stored in any magazine without regard to the direction in which they are pointed.

(4) Care must be exercised to protect electrically initiated rockets or rocket motors from being ignited by stray electrical currents such as currents that might result from contact with extension cords, lights, or electrical tools or close proximity to radio transmissions.

### **3-5. Inert or dummy ammunition and explosive**

*a. Storage.* Inert or dummy AE should not be stored in magazines with live AE when other storage space is available. When it is necessary to store inert AE with live AE, it will be segregated from live AE and clearly identified.

*b. Inert ammunition and explosives.* These include practice and service AE, including AE components (such as, projectile bodies) manufactured or made empty or inert for use in training, on desk nameplates or stands, on display boards, in demonstrations or public functions, in offices or work areas of engineers or other personnel, or similar purposes. AE will only be rendered inert by technically qualified personnel per established procedures. Activity, garrison or installation commanders will ensure that empty or inert AE and inert AE components used for any of the above or similar purposes that are under their control are properly identified.

*c. Identifying inert or empty ammunition and explosives and inert ammunition and explosives components.* Stenciling, painting, applying decals, or labeling inert or empty AE and inert AE components, which are used for the above or similar purposes, alone is not sufficient for identifying them as being empty or inert. Therefore, more positive identification is needed. The following procedures apply to each empty or inert AE or inert AE used for the above or similar purposes:

(1) Four holes no smaller than one-fourth inch will be drilled through each complete item. This includes fuze, body section, and cartridge case. The holes will be 90 degrees apart. When components such as detonators are too small for the one-fourth inch holes, fewer holes of smaller diameter may be drilled. Exceptions are indicated below.

(a) Inert or empty AE (for example, inert practice projectiles used in loading drills, inert bombs used in crew training or drills) or other empty or inert AE whose intended use would be impaired by drilled holes.

(b) Inert AE listed in supply manuals as standard for issue.

(c) Inert AE on permanent display in Army museums if such drilling would diminish their historical value. Such inert AE are suitably identified when permanently marked (for example, metal stamped) "INERT," "EMPTY," or "DUMMY."

(d) Approved training inert SAA (for example, 5.56mm, M199A1; 7.62mm, M63A1, and .50 caliber, M2A1) are exempt provided they are nickel plated and fluted.

(e) Approved training inert 9mm, M917A1 SAA, which is too small to flute, will be nickel plated with two holes sized based on PM guidance to prevent damage when used in applicable weapons systems.

(2) In addition to being drilled, all empty or inert ammunition or components will be stamped or stenciled with the marking "EMPTY" or "INERT." Markings must be clear and obvious.

(3) Inert, cloth-covered components (such as, bagged propelling charges) will be marked "INERT." Markings will be in durable, waterproof, fade-proof ink.

(4) Inert mortar sheet propellants will have the word "INERT" cut through each propellant increment.

(5) The SAA or small inert AE components mounted on wall plaques or display boards, in display cases, or permanent museum exhibits will have the word "INERT" on an attached plate. The plate could be of metal, wood, or plastic permanently affixed to the display.

*d. Inspections.* The EOD or other technically qualified personnel will inspect each inert AE that is part of a permanent museum display. Museum curators will use DA Form 2609 (Historical Property Catalog) to record the date of the inspection and the inspecting unit. The museum curator will note in the remarks section of DA Form 2609 that the AE was found to be or made inert.

*e. Rendering ammunition and explosives inert.* The conversion of a live AE to an inert condition for any purpose is prohibited unless approved by the ACOM, ASCC, or DRU commander and item manager. The inerting of AE is an explosives operation that will only be performed by technically qualified and authorized personnel at a location properly sited per Army and DOD siting criteria (see chap 8).

### **3-6. Modifications of ammunition and explosive and ammunition and explosive-related equipment for reuse**

*a.* AE converted from its original configuration (such as, fill) and AE-related equipment converted from its original configuration or function to another configuration or function that presents a lower risk will be marked and tracked.

*b.* Technically qualified personnel that make such conversions will permanently affix to the reconfigured (modified) AE or AE-related equipment a positive indication of the conversion (modifications made).

*c.* When converting AE with an HE fill to a training or target practice (TP) round, the personnel performing the conversion and any decontamination required to achieve the new hazard classification will permanently mark each item in a manner that conveys the modification made.

*d.* Processing equipment that is converted from use with HE for use with inert fills will be disassembled and inspected to ensure that any explosive residues are removed, and then similarly marked.

*e.* Personnel making such conversions will document the conversion process. This documentation will include the inspection and decontamination process used and will indicate how the process was verified. A copy of the record will accompany any shipment of modified AE or equipment.

*f.* Approval by the command, program manager (PM), or program executive officer (PEO) responsible for managing the article or equipment is a prerequisite for any conversion of this type. (See DODI 4140.62.)

### **3-7. Unserviceable ammunition and explosive**

*a. Sources.* There are a number of factors that can result in AE becoming unserviceable. These include, but are not limited to deterioration of metal parts or energetics; improper storage, handling, packaging, or transportation; or manufactured defects. Ammunition handlers should be trained to recognize indicators of unserviceable AE and report any suspected unserviceable AE for inspection by qualified personnel.

*b. Storage.* All suspended stocks of AE will be clearly marked and the lot-locator and magazine card posted to preclude issue. Within a magazine or single storage location (and where practical) all unserviceable or suspect AE will be clearly marked and segregated from serviceable AE, on separate pallets. The AE determined to be unsafe for



continued storage will be disposed of as soon as reasonably possible. The AE determined to be unsafe for continued storage that cannot be immediately destroyed will, when possible, be moved to a separate magazine or storage location or segregated from serviceable AE.

*c. Disposition.*

(1) The AE that has been determined unsafe for storage will be disposed of as rapidly as possible to preclude further deterioration and potential unsafe conditions. AR 75–15 provides guidance for disposing of unserviceable AE.

(2) When the commander of an ammunition unit or installation becomes aware of AE that has been determined by qualified personnel (such as, QASAS) to be unsafe for continued storage, the commander will order the destruction of AE and report this action to the appropriate headquarters and the designated disposition authority.

(3) The AE found on an installation, recovered from off the installations, or turned in under an installation’s amnesty program will be managed as unserviceable AE until it has been inspected by qualified personnel (such as, QASAS, EOD) and either returned to the stockpile or destroyed. Commercial AE recovered under any circumstances will normally be destroyed.

**3–8. Storage of captured enemy ammunition**

Captured enemy ammunition (CEA) will be inspected as soon as possible after acquisition to determine its condition, type, and caliber. Any special or unusual characteristics that could be of interest to technical intelligence personnel should be noted and reported through appropriate channels. CEA that has been determined to be unsafe for continued storage should be separated from serviceable stocks and disposed of as soon as possible. Serviceable CEA will not be stored together or with serviceable U.S. AE. CEA and CAE will be stored in an area separate from U.S. AE and inhabited building distance (IBD) from other AE. CEA that cannot be identified shall be treated as HD 1.1. Information on the NEW of foreign AE can be obtained from military intelligence elements. See table 3–1 for QD for captured enemy ammunition field storage and handling areas.

**Table 3–1**  
**Quantity distance for captured enemy ammunition field storage and handling areas**

TO	FROM Captured enemy ammunition
Storage sections	PTRD (note 2)
AE staging area	PTRD (note 2)
Captured enemy ammunition area	IMD (note 1) PTRD (note 2)
Ammunition and explosives operations area	PTRD (note 2)
Sling-out area	PTRD (note 2)
Administrative and billeting area	IBD (note 3)
Boundaries	IBD (note 3)
Manned nonexplosive support facility	IBD (note 3)
Unmanned nonexplosive support facility	PTRD (note 2)
Ammunition and explosives destruction area	Note 4

Notes:

<sup>1</sup> The IMD distance criteria in the upper half of the row is minimum separation distance required per chapter 9 of DODM 6055.09–M. The criterion in the lower half of the row is the asset preservation distance.

<sup>2</sup> PTRD includes minimum fragment distance.

<sup>3</sup> IBD includes minimum fragment distance.

<sup>4</sup> Per paragraphs C9.8.3 (Areas for Burning AE) and C9.8.4 (Areas used for Intentional Detonations) in DODM 6055.09–M.

**3–9. Chemical munitions (ammunition and explosive)**

Chemical munitions are munitions that contain fillers that include lethal chemical agents, riot control, incapacitating agents, smoke producing agents, and incendiaries. These munitions often contain a burster (pyrotechnic compounds) that upon use disperses the fill. The effects of chemical munitions depend primarily upon the chemical filler. Some chemical fills may also be contained and stored in bulk containers.

*a. Chemical groups.* For storage and handling purposes, chemical fills are divided into the below groups based on the action of the fill, the degree and type of hazard, and the type of protection required.

(1) *Chemical Group A.* chemical agents. See DA Pam 385–61. These fill can be toxic or incapacitating by inhalation, ingestion, or by absorption through the skin.

(2) *Chemical Group B.* This group consists of choking agents, blood agents, riot control agents, and screening smokes. Common examples include 2-chlorobenzalmalononitrile (CS), dibenzoxazepine (CR), chloroacetophenone (CN), sulfur-trioxide chlorosulfonic acid solution (FS), titanium tetrachloride (FM), and red phosphorous (RP). Wearing a suitable protective mask is required to protect personnel against inhalation of vapors, particles, or smoke from burning agents. Because these agents will cause varying degrees of skin irritation, approved types of protective clothing (such as, coveralls, protective masks, and gloves) will be provided and worn. These fill can be toxic or incapacitating by inhalation, ingestion, or by absorption through the skin.

(3) *Chemical Group C.* This group includes chemicals fills (such as, white phosphorous (WP) and plasticized white phosphorous (PWP)) that are spontaneously combustible when exposed to air. Group C requires special fire fighting techniques and materials. Personnel protection will be of a type that protects against fire and heat. Toxic fumes are an associated hazard.

(4) *Chemical Group D.* This group consists of signaling smokes, incendiary, and flammable munitions (for example, thermite (TH), isobutyl methacrylate with oil (IM), napalm (NP), pyrotechnic material (PT), hexachloroethane (HC)) material for which conventional fire fighting methods, with the exception of the use of water, may be used. Protection from inhalation of smoke from burning incendiary mixtures is required.

*b. Chemical munitions.* The same group designations as used for fillers will be used for chemical munitions.

*c. Structural requirements.* Chemical munitions or agents will not be stored in magazines with floors that are made of wood or other porous material into which chemical agents may be absorbed, making decontamination difficult.

*d. Handling.* Chemical munitions must be handled carefully. They should not be dropped or jarred. The same equipment used for handling HE filled AE may be used for handling chemical munitions.

*e. Outdoor storage.* When it is necessary to temporarily store Chemical Group B and C munitions outdoors, prior approval must be obtained from the ACOM, ASCC, or DRU on a case-by-case basis. When stored outside, these munitions should be covered with tarpaulins to protect them from the direct rays of the sun and from exposure to the elements. The exception is when the container itself affords reasonable protection from the elements. These munitions will be stacked in a manner that permits free circulation of air. Covering tarpaulins should be supported to permit a free flow of air under the tarpaulins.

*f. Handling of unserviceable chemical munitions or containers of chemical agent.*

(1) *Reporting of leaking or unserviceable chemical munitions or containers of chemical agents.* Leaking or damaged chemical munitions or containers will be immediately reported to the supervisor of the storage area. The supervisor will both initiate the procedures required to address the situation (such as, overpack) and accomplish ACOM, ASCC, or DRU directed reporting requirements.

(2) *Processing of unserviceable munitions or containers of chemical agent.* When damaged, leaking, or otherwise unserviceable munitions or containers are discovered, they should be marked immediately for easy identification. When practical, these munitions will be promptly overpacked, and removed from the storage structure for immediate disposal. If immediate disposal is not practical, then leaking munitions or containers should be segregated in a structure or area reserved for storage of defective or containers of chemical agent.

(3) *Disposal.* Bulk chemical fillers and chemical munitions or containers will not be disposed of by open detonation, land burial or disposal into waterways. Material (such as, production equipment, munitions, munitions residue, and other items) that has been contaminated with Chemical Group B, C, or D fillers will not be disposed of or released for sale as scrap until it has been thoroughly decontaminated per DA Pam 385–61 and documented as not presenting a chemical agent or explosives hazard. Specific decontamination procedures contained in applicable publications for such items take precedence over DA Pam 385–61.

*g. First aid.* Appropriate first aid and decontamination equipment will be readily available at each work site. Employees involved in operations that involve chemical munitions will receive—

(1) Annual first aid training on signs and symptoms of exposure to these chemical fills.

(2) Appropriate first, self, and buddy aid for each chemical filler.

(3) Training on how to use applicable first aid supplies and equipment.

*h. Disposition of defective chemical munitions.* Destruction of chemical fillers will be accomplished per requirements outlined in regulations for the specific type of chemical agent involved. As a matter of policy, open pit burning of incapacitating chemical filler or chemical-filled munitions in any quantity is prohibited. Additionally, open detonation of chemical munitions that contain a toxic chemical agent or industrial chemical fill will not be conducted without specific authorization by the Deputy Assistant Secretary of the Army (Environmental, Safety and Occupational Health) (DASA(ESOH)). Further information on methods for destroying large quantities of chemical fillers and munitions may be obtained, through channels, from the Director, Chemical Materials Agency or Commander, Edgewood Chemical, Biological Command, Aberdeen Proving Ground, Aberdeen, MD 21010–5423.

*i. Packing, marking, and shipping.* Chemical fillers, chemical munitions and components will be packed, marked, and prepared for shipment per current drawings and specifications for the item involved (AMC Drawing 19–48–75–5).

In addition, all applicable DOT regulations governing the shipment of chemical fillers and chemical munitions will be observed.

### **3-10. Chemical Group B chemical agents**

Fillers in this group (choking agents, blood agents, riot control, and smokes) require protective masks be worn when fumes or smokes are present.

### **3-11. Storage of Chemical Group B chemical munitions**

*a. Storage requirements.* Chemical Group B chemical munitions and containers should be stored in earth-covered magazines. Concrete floors treated with sodium silicate should be used. Ruberoid® or other floor coverings should not be used.

*b. Surveillance.* Periodic pressure testing and, in some instances, sampling of containers is required to detect increases in internal pressure before they become dangerously high. Surveillance also includes inspection to detect leaks, breaks, or other defects in containers and valves.

*c. Inspections.* Specific entry procedures will be incorporated into the movement and storage SOPs. If munitions or containers are leaking, protective masks will be worn and doors and ventilators will be opened. The leaking chemical munition or container will be located and disposed of per approved procedures (see para 3-13).

*d. Safety.* Protective masks must be readily available to all personnel working in magazines that contain Chemical Group B agent chemical munitions and containers. Protective gloves will be worn when handling unboxed chemical munitions with corrosive fillers (FM and FS). Unboxed chemical munitions and containers may be handled without protective gloves provided there is no chemical agent contamination noted. At least one person, who would be able to summon help if needed, should be carrying a protective mask in case of an incident.

(1) *Personal protective equipment.* The PPE consisting of protective masks, coveralls, and appropriate protective gloves, sufficient in number to equip all personnel required to work with Chemical Group B chemical munitions or containers will be centrally stored and maintained under close supervision. Personnel will be issued only serviceable protective masks, coveralls, and protective gloves. Personnel handling liquid corrosive chemical fillers will be issued and will wear eye protection, rubber boots, aprons, and gloves.

(2) *First aid equipment.* The following first aid equipment will be centrally stored and issued to the person in charge of a group of personnel required to work with Chemical Group B chemical munitions and containers:

(a) Gas casualty first aid kit and individual first aid kits.

(b) Stretchers or litters.

(c) Woolen blankets.

(3) *Decontaminating material.* The appropriate decontamination material and equipment, as identified in the chemical's material safety data sheet (MSDS), will be immediately available for responding to an accident or detection of a leaking chemical munitions or containers. Personnel will wear the minimum PPE as described in the MSDS unless otherwise directed by the local medical support organization.

### **3-12. First aid for Chemical Group B chemical agents**

When performing operations involving Chemical Group B chemical agents, all operations will be conducted with not less than two persons (buddy-system) with each person visible to the other at all times. Employees will be trained to recognize early symptoms in other personnel and be fully capable of administering first aid promptly and efficiently. After first aid treatment is completed, the victim will be evacuated for medical treatment (FM 4-02.285).

### **3-13. Leaking Chemical Group B munitions and containers**

Leaking Chemical Group B chemical munitions and containers must be disposed of per approved procedures. Personnel handling leaking chemical munitions or containers that contain corrosive Chemical Group B agents will wear appropriate rubber boots, rubber aprons, and rubber gloves in addition to protective masks normally worn. No leaking agent should be allowed to come into contact with skin or clothing. Pending final disposal, leaking munitions will be removed from the magazine and temporarily stored per directions in the SOP.

### **3-14. Removal of spilled Chemical Group B agent**

If Chemical Group B agent have leaked from chemical munitions or containers and have contaminated the floor or other containers, one of the treatments outlined in TM 3-250, chapter 5 will be used, depending upon the type of chemical agent involved. Protective masks, appropriate gloves, and boots will be worn during the procedure; if a corrosive agent is involved, adequate rubber boots and aprons will be worn.

### **3-15. Fire in magazines containing Chemical Group B agent munitions**

If a fire involves or threatens buildings in which Chemical Group B chemical munitions or containers are stored, all persons within three-quarters of a mile will be notified to evacuate the area until all danger is passed. Fire department and all others personnel involved in fighting the fire who may be exposed must wear a protective mask and coveralls. Danger to personnel downwind from a fire involving Chemical Group B filled chemical munitions and containers are

not great, unless noncombustible toxic fillers such as phosgene are involved. Chemical munitions or containers exposed to fire will be considered dangerous and will be inspected by qualified EOD personnel to determine their condition after the fire. A report of the fire will be prepared per the provisions of AR 420-1 and DA Pam 385-40.

### 3-16. Chemical Group C fills

*a. White phosphorous.* The WP is a yellowish, wax-like substance that melts at 110 degrees F. The WP's most characteristic property is that it spontaneously ignites when exposed to air, burning with a yellow flame and giving off a large volume of white smoke, which in field concentrations is usually harmless. Dense concentrations, however, may cause irritation of the eyes, nose, and throat. WP is intensely poisonous when taken internally.

*b. plasticized white phosphorous.* The PWP is finely divided WP suspended in a gel of rubber and xylene. Like WP, PWP is spontaneously combustible when exposed to air.

### 3-17. Storage for Chemical Group C munitions

Chemical Group C munitions should be stored in fire-resistive magazines with crack-free concrete floors. Storage in earth-covered magazines is preferred. Chemical Group C munitions will be stored per current drawings (AMC Drawing 19-48-75-5) and/or directives.

*a. Personal protective equipment.* The PPE consisting of fire resistant gloves and coveralls, and safety face shields, sufficient in number to equip all personnel required to work with Chemical Group C will be centrally stored and maintained under close supervision. This PPE will be issued to personnel working with WP or PWP filled and worn whenever a leak develops or is suspected. Approved protective masks will be immediately available at all times.

*b. Self-aid.* Self-aid comprises those aid measures that individuals can apply to themselves.

(1) If burning particles strike and stick to clothing, take off the contaminated clothing quickly before the phosphorous burns through to the skin. The immediate supervisor must decide whether to allow the burning clothing to burn itself out or extinguish it.

(2) If burning particles strike the skin, smother the flame with water, wet cloth, or wet sand. Keep the phosphorous covered with wet material to keep out air until the WP or PWP particles can be removed. WP and PWP will continue to burn unless deprived of oxygen.

(3) Try to remove WP or PWP particles with a knife, stick, or other available object. It may be possible to remove some particles with a wet cloth.

(4) Should WP or PWP get into the eyes, flush the eyes immediately with water. Tilt the head to one side, pull the eyelids apart with the fingers, and pour water slowly into the eye so that it will run off the side of the face to avoid the spreading of the WP or PWP.

(5) Report to the medical services as soon as possible.

*c. First aid.*

(1) First aid comprises the emergency actions undertaken to restore or maintain vital body functions in a casualty. Detailed procedures will be developed by local medical officials and documented in SOPs.

(2) When a casualty in a chemically contaminated area cannot put on their protective mask, the nearest person able to do so will mask the individual to prevent further exposure.

(3) Every individual able to do so must perform personal decontamination. If an individual is incapacitated, anyone present who can do so will decontaminate the individual.

(4) When WP or PWP particles are burning flesh, the affected portions of the body should be plunged under water to stop the burning. However, if WP or PWP particles are burning an individual's face or eyes, apply a continuous, gentle stream of water to the afflicted area or apply wet compresses until medical help is obtained.

*d. Disposal of contaminates.* Once the WP or PWP particles are removed, they must be placed in water-filled containers pending subsequent disposal to prevent additional injuries and eliminate the fire potential.

*e. Firefighting equipment.* When WP-filled AE are being handled, water-filled tubs, barrels, or tanks large enough to hold the largest WP-filled AE being handled will be located adjacent to magazines, outdoor stacks, or other work areas.

### 3-18. Leaking Chemical Group C munitions

*a. Detection.* Leaks in WP munitions can be detected immediately by the white smoke arising from the leak. As air contacts the WP, spontaneous ignition occurs. With leaking Chemical Group C munitions of this group, the greatest risk is fire.

*b. Immediate action upon discovering leaking munitions.* During operations, the person discovering leaking AE will, where practical, submerge the leaker in one of the water-filled tubs, barrels, or tanks provided. (Rubber protective equipment will not give adequate protection when exposed to high temperatures such as burning WP. When burning WP or PWP adheres to gloves, the gloved hand should be dipped into water.)

*c. Disposal of leaking Chemical Group C munitions.* When a single leaking item has been discovered and immersed in water, it should be disposed of, per locally-developed procedures, in an area where fragmentation will not be a hazard, smoke will not create a nuisance, and dry vegetation will not cause a fire .

### **3-19. Removal of Chemical Group C chemical contamination**

*a. Precautions.* If phosphorus (WP, PWP or RP) has leaked on the floor or other parts of a magazine and has been extinguished, a fire guard must be stationed at the building until the spill has been completely removed. The water used in fire fighting will evaporate and permit the chemicals to reignite; however, it may remain on the floor for some time before reigniting. Phosphorus that has extinguished itself by forming a crust can be reignited if the crust is broken.

*b. Removal procedures.* Provided all AE in the vicinity has been removed, small amounts of phosphorus can be removed best by first scraping off as much as possible and then removing the rest by burning with a blowtorch or similar appliance.

*c. Surveillance.* A magazine contaminated with Group C chemical contamination will be kept under surveillance for at least 2 weeks, as fire may break out again. Any deep cracks or crevices in the floor will be cleaned and filled up with cement mortar before AE is stored in the magazine.

### **3-20. Fire in a magazine containing Chemical Group C munitions**

*a. General requirements.* In the event of a fire in a magazine containing Chemical Group C munitions that are explosively configured (fuze or burster), the magazine will be evacuated if the fire cannot be rapidly controlled (fires in earth-covered magazines will not be fought.) Firefighting efforts will be confined to saving adjacent magazines. In fires involving Chemical Group C munitions that are not explosively configured, the fire fighting precautions in paragraphs "b" and "c" below will be observed.

*b. Control of flames.*

(1) Phosphorus, once extinguished, will either be immersed in water or continually sprayed to prevent the flames breaking out anew.

(2) The lowest water pressure stream that allows an approach to the fire should be used. High velocity streams of water tend to spread the fire.

*c. Safety.* Fire fighters will be closely supervised when fighting fire in magazines containing Chemical Group C munitions because such munitions may explode with moderate violence throwing burning munitions or WP for some distance. Fire fighters will be withdrawn to safe distances should this danger becomes apparent. Once ignited, RP has the same characteristics of WP and should be treated using the same precautions.

### **3-21. Chemical Group D chemical fills**

*a. Thermite.* Thermite, a mixture of iron oxide, aluminum, and other substances, is a dark gray granular mass that requires an igniter to start burning. TH burns with great rapidity at a temperature of 4,300 degrees F, with the iron oxide being reduced to molten iron. Thermite is a mixture of TH aluminum, barium nitrate, sulfur, and lubricating oil.

*b. Incendiary bombs.* Incendiary bombs may consist of a combustible body of magnesium metal alloy; inside is an igniter composition such as thermite. When ignited, the body of the bomb burns at a temperature of about 3,700 degrees F. Other incendiary munitions (such as, IM, NP, or PT filled bombs) have steel cases filled with thickened fuel. These munitions function by ejecting burning thickened fuel over a wide area. These mixtures are very difficult to extinguish.

*c. Colored smoke mixtures.* These mixtures contain a dye for the color of smoke desired and certain types of fuels. They do not contain HC.

*d. Triethylaluminum.* TEA is a pyrophoric colorless liquid that burns with a bright flame reaching temperatures approaching 2,300 degrees F. The TEA reacts violently with water. Thickened pyrophoric agent (TPA) is a thickened version of TEA.

### **3-22. Storage of Chemical Group D munitions**

Munitions containing Chemical Group D fill may be stored in any dry fire-resistive magazine.

### **3-23. Special protective equipment for Chemical Group D munitions**

Boxed and unboxed munitions containing Chemical Group D chemicals may be handled without special protective equipment; however, it is advisable to have protective masks available where incendiary materials or munitions are involved. Protective masks will be worn when exposed to burning munitions or bulk chemical.

### **3-24. First aid for Chemical Group D chemicals**

No unusual first aid treatment is required for personal injuries occurring from Chemical Group D chemicals. Burns should be treated in the same manner as those caused by flame. Persons severely affected from high concentrations of smoke should be evaluated by medical personnel.

### **3-25. Leaking Chemical Group D munitions**

Any leaking munitions containing Chemical Group D fillers will be segregated. Instructions for disposing of large quantities of such munitions will be requested from Headquarters, U.S. Army Materiel Command (AMCPE-SF) (2-1NE3903)), 9301 Chapek Road, Fort Belvoir, VA 22060-5527 If necessary to destroy small quantities of leaking

munitions of this group, they should be burned in a standard burning pit. Leaking bombs may be fired statically in a pit of a demolition ground where the fire risk is negligible. If the bombs do not contain an explosive charge and barricade protection for personnel is not available, a distance of 300 yards will be maintained. Use criteria outlined in chapter 8, if the bombs contain an explosive charge.

### **3-26. Fire in magazine containing Chemical Group D munitions**

a. Fires in earth-covered magazines will not be fought. The primary efforts of the fire fighters will be confined to preventing the spread of the fire in magazines containing Chemical Group D munitions. Normally, water is not used to fight fires of TH or mixtures containing fine metallic powders such as magnesium or aluminum. Incipient fires may be smothered by spraying the dry chemical from first aid extinguishers or covering with sand. Fire in a magazine containing Chemical Group D munitions will not be fought with water except where large quantities are used in proportion to relatively small quantities of these type munitions.

b. TEA is explosive in water. Inert materials (for example, sand or dirt) are the best means to extinguish a TEA fire.

### **3-27. Termination of use of facilities storing ammunition and explosives**

When a storage facility is no longer used to store AE it must, within 180 days from the day of last use, undergo a process to ensure that all AE has been removed and that no visible explosives residues are present. These procedures help eliminate any potential explosive hazard or threat to human health and the environment.

*Note.* (Ammunition storage units (ASUs) that have been used to store WMM must also comply with the closure procedures in chapter 18.)

These procedures include the following:

- a. Emptying the storage facility of all AE and related materials.
- b. Cleaning the storage facility, as required, to remove any visible explosives residue.
- c. Visually inspecting the storage facility for the presence of remaining AE or visible explosives residue by a knowledgeable individual that the garrison, installation or responsible activity commander appoints.
- d. Removing from the storage facility all fire and chemical hazard symbols and marking the storage facility as empty.
- e. Securing the storage facility to prevent inadvertent use or access. Empty magazines must be sealed with a numbered seal to ensure that it is not used to store AE without proper notification of ammunition, security, and surveillance organizations. Local procedures must ensure notification. At a minimum, the integrity of the seals will be verified once every 12 months.
- f. Notifying emergency response and regulatory authorities of the change in the storage facility's use.
- g. Recording, in permanent real estate records, the date the storage facility was inspected, the name and position of the inspector, and the results.

## **Chapter 4 Safety Site Planning**

### **4-1. Explosives and toxic chemical safety site plans**

An explosives/toxic chemical agent safety site plan describes in text and graphics the relationships between PESs, ESs, toxic chemical sites, facilities, the environment, and personnel. They also contain descriptions of construction specifications for facilities and specifications and placement of required auxiliary equipment (for example, dividing walls, lightning protection systems, utility service lines, conduits). They are submitted to the US Army Technical Center for Explosives Safety (USATCES) for DDESB approval of the particulars of the plan from an explosives safety perspective as required in DOD regulations.

*Note.* DA Pam 385-65 and Explosives Safety Site Plan Developer's Guide (<https://www3.dac.army.mil/es/usatces/>) are resources to assist personnel who are preparing or reviewing site plan submissions.

- a. The DDESB approval of these safety submissions is required whenever an Army organization or facility:
  - (1) Establishes a new PES or toxic chemical agent site that does or does not require construction. Examples of facilities that require submittals are those locations where AE or toxic chemical agents are developed, used, manufactured, tested, stored, repaired, modified, or destroyed.
  - (2) Modifies an existing sited facility by either increasing the potential hazard present or changing the facility's use to effect adversely its QD or chemical interrelationships. Examples of this criterion are changes to the hazard classification of AE present, initiation of dissimilar activities, increased NEW or toxic chemical agent hazard, or introduction of explosives into a previously exclusively toxic chemical site.
  - (3) Plans major modification of the construction features of an existing potential explosion site.
  - (4) Establishes a site that does not contain AE within the QD arcs of a PES.

- (5) Determines that an Army or DDESB- approved explosives safety site plan does not exist for an existing ammunition, explosives, or toxic chemical site.
- (6) Designates a site previously only used for temporary storage of AE as a permanent AE or toxic chemical site.
- (7) Establishes a site (other than those listed para 4-1b(1), below) that will be used repeatedly, although not continuously, as an ammunition or toxic chemical site .
- (8) Removes restrictions on AE or toxic chemical operations that cause new exposure of previously unexposed sites to blast, fire, fragment, or toxic hazards.
- (9) Establishes range support facilities (such as, ammunition holding areas, storage pads, supply points, ammunition transfer points (ATPs), loading docks, burn pans, and handling areas) that are designed, constructed, and used on operational ranges and training facilities for recurring AE-related administrative support for training. Range support facilities that are only used to store and handle HD 1.4 ammunition do not require explosives safety site plans.
- (10) Identifies areas used repeatedly for tactical field training in AE support operations (for example, a grid square within a range used for training units in the establishment of field ASP's or ATP's). These areas will be sited as an external footprint for anticipated AE operations. Tactical positions (such as, field ASPs and ATPs) within such sited areas that are an inherent part of a training scenario do not require an explosives safety site plan. However, units training within these tactical areas will perform a risk analysis of AE operations to ensure such operations do not present a potential explosives safety risk to other units or assets.
- (11) Establishes locations that are to be used for training EOD personnel, combat engineers, and other ammunition technicians in the destruction or treatment (for example, open burn or open detonation) of AE. However, when such locations are on a range impact area that is sited per AR 385-63 and the QD arcs remain within the controlled area of a range, the locations do not require an explosives safety site plan. This does not include locations for detonations for combat training purposes (cratering, cutting steel, or timber, or similar combat engineer missions).
- (12) Establishes locations that are or will be permitted by Federal or State environmental protection agencies for treatment of explosives, regardless of other uses.
- (13) Establishes or designates locations for equipment (such as, brass deformers) used to process spent cartridge cases, range residue, and so forth.
- (14) Intends to use explosives, even when such use is contracted to commercial firms specializing in implosion or other destruction techniques, to demolish facilities, structures, or equipment on or off an installation.
  - b. An explosives safety site plan is not required for facilities or unimproved locations as follows:
    - (1) Operational ranges (such as, training, testing) where AE is used for which approved surface danger zones have been developed per AR 385-63.
    - (2) Firing positions, for both direct and indirect weapons systems, regardless of weapon system, that meet established local range control requirements.
    - (3) Ranges support facilities that are only used to store and handle HD 1.4 ammunition.
    - (4) Facilities and locations that do not meet the definition of a PES and are located beyond the IBD of existing or planned PESs.
    - (5) Locations at which this pamphlet states that the proposed facility may be located without regard to QD considerations.
    - (6) Facilities and locations that do not comply with all Army/DOD siting criteria. See paragraphs 1-4g and 1-4h, below.
    - (7) The AE sites that were built prior to 1 January 1958 (provided the site is still used for its original purpose and no new PES or ES have impacted the original siting). The date of construction and original use information must be documented in the permanent files of the garrison or installation.
  - c. Site plans are not required to be submitted for the specific situations listed below. ACOMs, ASCCs, and DRUs will specify siting and documentation requirements for these situations.
    - (1) Interchange yards limited to those operations described in table 8-6.
    - (2) Inspection stations where only the operations described in table 8-6 are performed.
    - (3) Transportation mode change locations that involve roll-on/roll-off operations where no lifting is involved, and for off-installation MILVAN/ISO container inter- or intramodal-transfers (involving highway and rail modes only) where containers are not stored or other operations are performed (see para 8-33b(3)).
    - (4) Parking of aircraft loaded with specific munitions (see para 8-32), while in designated aircraft parking areas that meet airfield criteria, and associated handling of these munitions, provided the quantity of munitions involved in the operation is limited to a single aircraft load.
    - (5) The handling of HD 1.3 and HD 1.4 material (300 pounds NEW or less) necessary for ships' security and safety-at-sea (see para 8-33).
    - (6) Certain contingency and combat training operations as described in chapter 9.
    - (7) Storage and associated handling of HD 1.4S.
  - d. While the provisions for submitting safety site plans and specifications do not apply to the following, the following must be issued an approved explosives license:

- (1) Temporary and emergency facilities to be located in areas in which the U.S. Army is engaged in:
  - (a) Combat operations.
  - (b) Contingency operations (hostilities may be imminent).
  - (c) Temporary, nonrecurring operations (not to exceed 30 days) such as engineering tests, exercises, training events).
- (2) Minor modifications to or rehabilitation of existing facilities necessary to:
  - (a) Support an emergency requirement for a limited time, not to exceed 30 days.
  - (b) Provide operating or maintenance line modifications due to manufacturing process changes or adapting a line to other end items where modifications do not introduce additional risks or increase the net explosives capacity or chemical agent hazard for which the facility was designed or sited.
  - (c) For locations where mission essential or operational necessity requires, storage of AE in quantities of:
    - 1. Unlimited amounts of HD 1.4 or 6.1 (excluding toxic chemical munitions).
    - 2. Up to 100 lbs NEW HD 1.3.
    - 3. Up to 50 lbs. NEW HD 1.2.2.
  - e. When an Army element is uncertain if whether a site plan is required, the ACOM, ASCC, or DRU of the garrison or host installation will make the determination. Should the ACOM, ASCC, or DRU be uncertain as to the requirement, it should request guidance from the Office of the Director of Army Safety (ODASAF) or USATCES.
  - f. NEW limits listed in explosives safety site plans will be determined based on the activity (such as, storage, transport) to take place at the site and the separation distances available.
    - (1) Normally locate storage PESs to achieve the maximum NEW of each AE hazard class/division (1.1, 1.2, 1.3, 1.4, and so forth) that may be present at the proposed site, based on available separation distances.
    - (2) NEW limitations at operating sites should consider the quantities and types of AE required to conduct the intended operations and available separation distances.
    - (3) Locations reserved for future sites should be considered when determining or reviewing proposed site locations.
    - (4) ACOM, ASCC, or DRU approval authorities may provide further limitations through correspondence conveying DDESB approvals to the submitter or through the licensing process.
  - g. Where new construction or major modifications of existing facilities do not comply with all siting criteria a CCR must be prepared and approved prior to initiating construction. See AR 385–10, chapter 5 for criteria for obtaining in this situation.
  - h. When siting criteria cannot be met for an ES or PES, a CORA must be approved per DA Pam 385–30.

#### **4–2. Explosives safety site plan contents**

See DA Pam 385–65 for information on explosives safety and chemical site plan preparation and submission procedures.

## **Chapter 5 Explosives Licensing**

### **5–1. Explosives licenses**

Explosives licenses are issued to all facilities storing ammunition or explosives and have no expiration date. Licenses must be reviewed and validated at 12-month intervals.

### **5–2. Procedures**

a. The garrison commander or their designated official will license explosives storage for every separate location where he/she authorizes storage of Class V items on the installation. Explosives storage licenses can be more restrictive than the DDESB explosives safety site plan upon which they maybe based, but cannot allow presence of more NEW or hazard classes of ammunition. Examples of requiring locations (which may or may not be present on all installations) are—

- (1) All AE storage facilities.
- (2) Arms rooms.
- (3) Reaction force AE storage sites.
- (4) Training AE storage sites.
- (5) Aviation Life Support Equipment and AE (such as, CADs), PADs, flares, signals) storage rooms.
- (6) Rooms where document destroyers or thermite grenades are stored.
- (7) Guard rooms.
- (8) Military police/security force facilities.

b. The Garrison Commander’s designated Safety Office will—

- (1) Develop and manage the installation Explosives Storage License Program.



- (2) Review license requests when submitted by operating/using units.
- (3) Request that operating/using units initiate the license process when it becomes aware of the presence of ammunition in an unlicensed location.
- (4) Provide the final staff concurrence sign-off prior to forwarding to the designated official for approval.
- c. Mission or unit commander's safety office will—
  - (1) Develop a license based upon mission requirements.
  - (2) Coordinated with installation elements (physical security, fire protective services, ammunition surveillance) to determine appropriateness of proposed sites, operating procedures and limitations.
  - (3) Prepare a risk assessment to support each license not supported by a DDESB-approved explosives safety site plan. The risk assessment will be submitted with the license for consideration by the approval official. Documentation of the risk assessment will be maintained in the designated safety office. Documentation of the risk assessment will be part of the license and maintained with all copies of the license.
  - (4) Forward the license to the Garrison Safety Office for review and staffing to the designated official for approval.
- d. Explosives licenses will be reviewed at 12 month intervals for compliance and encroachment issues. This review will include an on-site inspection of the area by a competent individual. Documentation of the reviews will be maintained at the garrison safety office.
- e. The explosives license, maps of the explosives location, and surrounding area, will be available at both the using unit safety office and the garrison safety office.
- f. Arms room licenses will be posted in the arms room.
- g. Copies of explosives licenses will be maintained at the AE operations controlling office.
- h. Tenants will comply with host installation requirements.

### **5-3. Required information**

The explosives license form will, as a minimum, contain the following information:

- a. Ammunition or explosives area name.
- b. Ammunition or explosives facility location.
- c. Date of issue.
- d. Analyst.
- e. Authorized limits of each HD (expressed in pounds (NEW) or kilograms (net explosive quantity (NEQ))).
- f. The limiting exposed site for each HD with the distance to that exposed site (excluding arms rooms).
- g. The greatest level of risk associated with the facility when an approved site plan does not exist.
- h. Any notes pertinent to the facility.
- i. The name and title of the signing official and date of issuance.
- j. The name of the individual conducting the periodic inspection to assure compliance and the date of the inspection.

## **Chapter 6 Fire Prevention, Protection, and Suppression**

### **6-1. Fire prevention management**

- a. Fire and excessive heat are two of the greatest hazards to explosives. Many ammunition and explosives items are extremely sensitive to heat and react at temperatures substantially lower than those required to ignite ordinary wood, paper, or fabrics. Even indirect heat generated by a fire could initiate a reaction and result in an explosion. This chapter gives procedures for dealing with these hazards.
- b. Fires that may occur in buildings or magazines containing ammunition or explosives will vary in intensity and effect, depending on the material involved in the fire. Certain explosives will ignite immediately on contact with a spark or flame or when subjected to frictional heat or concussion. Some explosive substances may burn freely while others will be subject to explosion while burning or will develop such intense heat, as in the case of solid and liquid propellants, that firefighting efforts will be practically impossible. Firefighting forces will be well acquainted with the risks involved in each fire hazard group and the best methods of fighting fires of all kinds of materials under their protection. They should also know how to use personnel protective devices required for the various types of fires.
- c. Each garrison or installation involved in explosives operations will develop pre-fire plans in accordance with AR 420-1. Plans will cover all explosives areas and possible exposures of explosives to fire. In addition to the requirements of AR 420-1, the overall plan will specify responsible individuals and alternates, their organizations and training, and include a description of the emergency function of each department or outside agency. Duties of personnel spelled out in the plan will include the following:
  - (1) Reporting the fire.
  - (2) Directing orderly evacuation of personnel.

- (3) Notifying personnel in nearby locations of impending dangers.
- (4) Activating means of extinguishing or controlling the fire.
- (5) Meeting and advising the firefighters on the details of the fire up to the time of their arrival.
- d.* Each Army fire station central communications center will have an area map showing all explosives areas or locations. Locations with less than 1,000 rounds of HD 1.4 small arms ammunition (.50 caliber or less) are exempt.
- e.* Personnel in charge of explosive operations will notify the fire department when there is a change in the type of explosives being worked which would require a change of fire or chemical hazard symbols.
- f.* Where explosives, highly flammable, or energetic materials are involved, a written permit is required for using heat-producing equipment capable of reaching a temperature higher than 228 degrees Fahrenheit (F) (109 degrees Celsius (C)). (See para 6–8a and AR 420–1 for additional guidance.)
- g.* Matches or other flame or spark producing devices will not be permitted in any magazine area or explosives area unless the commanding officer or his or her designated representative provides written authority. When such authority has been received, a carrying device, too large to fit into the pockets, will be used for matches, lighters, and similar materials.
- h.* Carrying and using “strike anywhere” (kitchen) matches are prohibited in/around ammunition and explosives facilities.
- i.* All flashlight or storage-battery lamps used in buildings containing hazardous quantities of exposed explosives or flammable vapors will be certified for the hazardous environment by the United States Bureau of Mines or by a similarly recognized testing laboratory for that specific type of exposure.

## **6–2. Instructions for fighting fires involving ammunition or explosives**

- a.* When a guard, watchman, or other person discovers smoke coming from a closed magazine, or sees any evidence that a magazine is on fire, he or she will give the alarm as quickly as possible and evacuate to a safe distance. He or she will not enter a burning building or magazine, nor open the building or magazine door if a fire is suspected.
- b.* If a fire is discovered in grass or other combustible material surrounding a magazine, the alarm should be given immediately and the guard should do all that is possible, using available firefighting tools to extinguish or control the fire until firefighting forces arrive. It is important to extinguish grass fires especially when they are close to magazines. If a fire has actually started inside a magazine, firefighting forces should either combat the fire or seek the nearest suitable protection, depending on the type of ammunition or explosives with the magazine.
- c.* When a workman or other person discovers a fire in a building where people are working and explosives are present, a suitable fire signal will be given and all personnel present will be evacuated. At least one responsible manager will be dispatched in the direction from which the fire department is expected to come, to inform firemen of the location, nature, and extent of the fire. The officer in charge of firefighters will not permit personnel to advance until accurate information is available about the existing hazard and concludes that the advance is justified.

## **6–3. Smoking**

Smoking is prohibited in any explosives storage or operating area or location, except as permitted below.

- a.* Smoking may be allowed within an explosives area or location in specially designated and posted “authorized smoking areas.” A certification of approval by the garrison or installation commander or his or her designated representative (fire chief, fire marshal, or fire warden), in coordination with the safety office, will be displayed in each designated smoking location.
- b.* In “Authorized Smoking Areas,” the following minimum precautions will be taken:
  - (1) Suitable receptacles for cigarette and cigar butts and pipe heels will be provided. (Smoking residue will not be placed in trash receptacles until it has been determined that no flammable or combustible risk exists.)
  - (2) If electric power is available, push-button electric lighters that cut off when pressure is released will be used. Lighters will be permanently installed to prevent removal and use outside the designated area.
  - (3) Where intervening noncombustible walls are not available to separate a potential smoking area from an area where ammunition and explosives are present, the smoking area shall be separated by a distance of at least 50 feet from the ammunition or explosives.
  - (4) At least one portable fire extinguisher with a 1A or greater rating will be provided at each designated smoking area.
  - (5) Personnel whose clothing is contaminated with explosives or other hazardous materials will not be allowed in smoking areas.
  - (6) Personnel working with hazardous chemicals or material must wash their hands before smoking.
  - (7) A “No Smoking” sign will be posted at each entrance to an explosives storage area. Where applicable, include a notice that flame-producing devices must be turned over to the entry controller or placed in the container provided.
  - (8) Smoking is prohibited in, on, or within 50 feet of any motor vehicle, trailer, railcar, or material handling equipment loaded with explosives items.
  - (9) Smoking is prohibited in any explosives-laden compartment of an aircraft.

#### **6-4. Training**

All operating personnel and firefighting forces involved with explosives must be trained in the precautions to be taken and how to fight fires. This training will include the application and meaning of each type fire hazard symbol, reporting fires, sounding alarms, area evacuations, and type and use of appropriate firefighting equipment. See chapter 1, table 1-1, and applicable tables at the end of this chapter.

#### **6-5. Fire drills**

Fire drills will be held within the explosives areas at intervals of 6 months or less. See table 6-4 for withdrawal distances.

*a.* Drills are conducted to train firefighting forces and ensure other personnel involved understand their duties and to evaluate fire alarm systems and firefighting equipment.

*b.* Fire drills involving a fire department response will be coordinated with the fire chief. This does not preclude unannounced tests of a fire department's response capabilities, provided adequate prior coordination with the fire chief is accomplished. Personnel who conduct these tests will make sure all personnel in the area are aware that an exercise, and not a real fire, is in progress.

#### **6-6. Fire exit drills**

Frequent fire exit drills should be held when warranted by the size of the building and the number of occupants. If emergency exits other than the usual doors and stairways are provided, these drills will cover their use. All emergency exits will have exit signs which are clearly visible. Signs will meet the requirements of 29 CFR 1910 Subpart E - Exit Routes, Emergency Action Plans, and Fire Prevention Plans and The Life Safety Code (NFPA 101).

#### **6-7. Alarms**

In addition to any fire detection systems required by AR 420-1 or other applicable directives, an audible, manually operated fire evacuation alarm system should be installed in each explosives operating building. All alarm systems will be clearly labeled.

#### **6-8. Fire prevention requirements**

*a. Heat-producing devices.* The use of devices that produce temperatures higher than 228 degrees F (109 degrees C) in any explosives area should be confined to essential, temporary use. Written instructions and a DA Form 5383 (Hot-Work Permit) are required before beginning work. They should cover the location, purpose, duration, and details of general and explosives safety precautions to be used. Approved furnaces, electrical space heaters, and electrical cigarette lighters that are properly installed in an operating building are exempt. Bilingual instructions are required in foreign countries where local employees are included in the work force.

*b. Control on wax pots.*

(1) All wax pots regardless of size will be equipped with a power indicator light, lids with fusible link, and placed on noncombustible surfaces.

(2) Wax pots with a capacity in excess of one gallon must be equipped with dual temperature controls.

*c. Vegetation control.* The primary purpose of vegetation control is to limit the potential spread of an uncontrolled fire in ammunition and explosives storage and operating locations. Maintaining control of combustible materials, such as long dry grass or brush, heavy clippings, or dead wood, are designed to slow the spread of a fire. Garrison or installation safety offices must determine what vegetation control measures are required and develop a vegetation control program. The following items should be considered in a vegetation control program:

(1) Except for firebreaks, grounds in or near explosives areas or locations should be maintained as unimproved grounds.

(2) Periodic maintenance by mowing or application of herbicides should be accomplished. Such maintenance should be limited to prevent waste of natural resources (for example, erosion) and to prevent or suppress fires. Intensive maintenance should not be performed.

(3) Vegetation control requirements must be balanced with other operational factors such as cost to control, security, erosion prevention, and passive defense (camouflage). Each of these factors must be weighed in determining the level of vegetation control in and around a particular explosives area.

(4) Varieties of vegetation that are resistant to burning should be used wherever feasible. If removal of vegetation will cause soil erosion, soil sterilants will not be used. Shrubs and trees planted on the earth-cover of magazines should be selected so that their weight or root system will not damage the structure. Dead or cut vegetation must not be allowed to accumulate.

(5) When animals are used for vegetation control, overgrazing of barricade surfaces and magazine earth cover must be avoided to prevent erosion.

(6) Where vegetation growth is ineffective in preventing erosion, a layer of approximately 2 inches of pressure-applied concrete (Gunitite) or asphalt mixture may be used.

(7) When using controlled burning as a vegetation control measure, the garrison or installation conducts a hazard

analysis and develops both a burn plan and an SOP for controlled burns. The burn plan must address all state and local requirements for outdoor burns, and will be coordinated internally with the safety office, munitions surveillance office, and the garrison or installation fire department. When appropriate, external coordination with environmental regulators, safety officials, and fire departments providing mutual support to the garrison or installation will be addressed in the burn plan and SOP. The following guidance is provided:

(a) Controlled burns are not allowed within 100 feet of military munitions operating buildings containing open (exposed) explosives or of open storage pads. This is a minimum distance and consideration should be given to increasing the distance based on local conditions (for example, fuel load of the area being burned, weather conditions, and so forth).

(b) Controlled burns are allowed within earth-covered magazine storage areas. This authorization includes the combustible vegetation on the earth cover as well. When burning vegetation on or near the earth covering, magazine vents will be closed and the rear vent will be covered.

(c) The windows, doors, and ventilators of all magazines and/or operating buildings within 100 feet of controlled, burns will be closed.

(d) All firebreaks will be inspected for adequacy prior to a controlled burn.

(e) Those firefighting personnel and all equipment that the fire chief determines necessary will be present prior to and throughout the completion of the controlled burn.

(f) Training will be provided to all personnel involved in the controlled burn.

(g) Controlled burns will not be conducted if the wind speed is higher or lower than allowed by local ordinance requirements, or is less than 5 miles per hour or exceeds 15 miles per hour, whichever is more restrictive.

*d. Flammable liquids for cleaning.* Flammable liquids will not be used for cleaning within an explosives area or near explosives, except as authorized by approved SOPs. Flammable liquids will be used in explosive areas only when authorized by approved SOPs. In-use stocks will—

(1) Not exceed one workday's supply;

(2) Be kept in approved safety containers or dispensers; and,

(3) Be removed at the end of each workday.

*e. Petroleum, oils, and lubricants fire separation distances.*

(1) *POL storage location requirements.* The NFPA Standard 30 specifies fire clearance criteria from POL locations. If required fire clearances are greater than those required by this regulation, use the greater required separation.

(a) Anti-siphon systems will be used where applicable.

(b) Any aboveground petroleum storage tank which has a capacity of 2,000 gallons or more must be enclosed within a dike area as prescribed in 29 Code of Federal Regulation (CFR) 1910.106 and NFPA Standard 30. The capacity of this diked area must equal the capacity of the largest tank within the diked area.

(2) *Quantities of 500 gallons or less.*

(a) Where tanks serve equipment (such as oil heaters or diesel generators) located in explosives buildings, anti-siphoning devices will be used. They are not needed if the level of the tank installation is such that siphoning is impossible.

(b) Above ground petroleum facilities (such as tanks, pumps, or pump houses) will be located a minimum of 50 feet from explosives locations.

(3) *Parking fuel service trucks.* Parking areas for fuel service trucks will be located a minimum of 50 feet from explosives locations.

(4) *Mobile dispensing units.* There must be at least 100 feet between explosives and any mobile petroleum dispensing unit operating in an explosives area, unless a shorter distance is needed during transfer operations to an underground tank (as allowed under (2) above).

(5) *Liquid petroleum gas facilities.* LP gas facilities will meet the requirements of this section.

(6) *Vehicle refueling.* Gasoline and diesel-powered vehicles and equipment will not be refueled inside any structure in the explosives storage area or in any facility, site, revetment, or other building containing explosives, regardless of location. When being refueled, vehicles will be at least 100 feet from structures or sites containing explosives. When refueling is completed, the refueling vehicle must be removed promptly from the storage area.

(a) Use the smallest available refueling unit consistent with the mission.

(b) When refueling explosives-loaded vehicles, maintain an electrically continuous bonding path between the vehicle being filled and the tank being emptied. The entire system will be grounded.

(c) Do not allow smoking or open flame devices within 50 feet of gasoline or diesel refueling. At least one person must be present during the entire operation. During the refueling, stop the motor of both the vehicle being refueled and the refueling truck (unless the refueling truck motor drives the pump).

(d) If a fuel spill occurs, immediately notify the garrison or installation fire department. Do not start the motors of the refueling truck or unit being refueled until the area is rendered safe by the fire department.

(e) Refueling will not be done within 20 feet of an inert ammunition storage building or loading dock.

(7) *Exceptions.* The following are excepted from the above requirements:

- (a) Separation of POL facilities and aircraft during combat or simulated combat operations.
- (b) Separation between POL hydrants set on the flight line flush with the pavement and explosives loaded aircraft or explosives loading or unloading operations.
- (c) Diesel-powered generators may be equipped with an operational “day-tank” of the smallest size needed to operate the motor properly. Supply tanks will be separated by the applicable underground or aboveground criteria.
- (8) *Siting*. Do not locate ammunition and explosives within the drainage path downstream of temporary or permanent POL sites.
- f. Paint and other flammable materials*. Small stocks of flammable materials, such as paints and solvents required to support explosives maintenance operations, may be stored in an explosives storage area in accordance with 29 CFR 1910.106.
  - (1) Combustible materials, such as wood, paper, and rags, will not be stored with flammables. Containers of flammable materials will be closed, except when in use.
  - (2) Flammable materials in approved weatherproof containers may be stored outdoors. Grounding and bonding are required when contents are being dispensed.
  - (3) Flammable storage will be located at least 50 feet from explosives locations.
  - (4) A limited supply of paint, not to exceed a one-day requirement, may be stored in explosives operating facilities if stored inside cabinets designed for flammable material storage.
  - (5) At least one fire extinguisher, suitable for the type of materials involved, will be readily available for use (see table 6-1).
- g. Vehicle parking*. Vehicles, except during loading or unloading, will not be parked closer than 50 feet to any noncombustible explosives facility or 100 feet for combustible facilities. APE 1965 or other approved shelter may be parked at magazines while in use, and may remain there unattended as long as all munitions or explosives are removed from it and returned to the storage structure.
- h. Operating support equipment*. The following applies to all support equipment powered by internal combustion engines used with explosives and not otherwise regulated under paragraph 2-17.
  - (1) This equipment should be located 50 feet or more from explosives but shall be no less than 25 feet from explosives operations or facilities. In the case of mobile shelters or other support equipment that includes built-in generators, the generator will be physically separated from any ammunition by being housed in an exterior compartment on the shelter. The generator will be maintained at least 50 feet from the supported magazine.
  - (2) Only qualified personnel will use the equipment.
  - (3) The equipment will be inspected for cleanliness and visual defects before each use. Defects will be documented on the applicable forms. Equipment that is malfunctioning or has defects that present a hazard will be removed from the operational site for repairs.
  - (4) One fire extinguisher rated 10BC or higher (1-A: 10-B: C recommended) for flammable or combustible liquid fires (Class B fire) and electrical fires (Class C fire) will be readily available.
  - (5) Equipment powered by gasoline or diesel fuel will not be refueled within 100 feet of explosives. LP gas-powered equipment may have its fuel container replaced, as long as the magazine is closed, no ammunition operations are in progress at the site, and the equipment is not in use at the time of fuel container exchange.
- i. Stacking combustible material*. Containers, dunnage, lumber, and other material will be stacked in an orderly manner. Stacks should be limited to an area of no more than 1,500 square feet. Bulk stacks of combustible materials should not be closer than 1LD from locations containing explosives (use chapter 8 to establish minimum separations). Working quantities may be stacked in the vicinity of explosives. Portable fire extinguishers or water barrels should be provided in these areas.
- j. Exceptions on stacking combustible material*. When needed to prepare for combat operations, empty containers, dunnage, and lumber that cannot be removed while the work is in progress may be temporarily stacked in or near the explosives storage site, provided—
  - (1) The stacks are stable and are separated from the operations as far as practical.
  - (2) All of the materials are removed upon completion of the operation or once each day (24 hours).

## 6-9. Firebreaks

Firebreaks will be kept clear of all readily combustible material, such as dry grass, dead wood, or brush. The level of live vegetation to be permitted in firebreaks (except those around earth-covered magazine ventilators) will be determined as outlined in paragraph *c*, above.

- a*. A 50-foot firebreak will be maintained around each aboveground magazine, operating building or location, outdoor storage site, and ready explosives facility.
- b*. A 5-foot firebreak will be maintained around earth-covered magazine ventilators.
- c*. A 5-foot firebreak will be maintained on both sides of fences (for example, magazine area fences, production line

fences, boundary fences). Where access to the outside of the fence is not available (such as, garrison or installation boundaries) the fire break will be doubled on the interior side of the fence.

#### **6-10. Auxiliary firefighting equipment - fire extinguishers**

*a.* A minimum of 2 fire extinguishers suitable for the hazards involved will be available for immediate use when explosives are being handled. Extinguishers need not be permanently located at the site. Each extinguisher will be placed in a conspicuous and readily accessible location. Each fire extinguisher will be kept in a full, or fully charged, operable condition. Table 6-1 lists agents for fighting fires.

*b.* Personnel with responsibilities for using fire extinguishers will receive training on general principles of fire extinguisher use and the hazards involved with incipient stage fire fighting upon initial assignment and at least annually thereafter.

#### **6-11. Storage of water for firefighting**

*a.* Adequate water to fight fires must be available at permanent explosives facilities. The required amount of water will be calculated in accordance with Unified Facilities Criteria (UFC) 3-600-01.

*b.* The minimum water supply will not be less than 3,000 gallons.

*c.* The following will be used as guidelines in separating water supplies from explosives:

(1) Water tanks shall be separated from explosives per chapter 8.

(2) Sectional control valves will protect the water distribution system so that damaged sections of the main can be cut off without impairing the operation of the remainder of the system. Water mains will not be located under railroads or roads used for conveying large quantities of ammunition or explosives, as a detonation may cause a main to break.

#### **6-12. Public withdrawal distances**

*a.* Emergency withdrawal distances for nonessential personnel are intended to apply in emergency situations only and are not to be used for facility siting. Emergency withdrawal distances depend on fire involvement and on whether or not the hazard classification, fire division, and quantity of explosives are known. The withdrawal distance for essential personnel at accidents shall be determined by emergency authorities on site. Emergency authorities shall determine who essential personnel are.

*b.* If a fire involves explosives or involvement is imminent, then the initial withdrawal distance applied will be at least inhabited building distance. When emergency authorities determine that the fire is or may become uncontrollable and may result in deflagration and/or detonation of nearby ammunition or explosive material, all nonessential personnel will be withdrawn to the appropriate emergency withdrawal distance listed in table 6-4. If fire is not affecting explosives or involvement is not imminent, then emergency authorities shall determine the withdrawal distance based on the situation at hand.

*c.* Structures or protected locations offering equivalent protection for the distances listed in table 6-4 may be used instead of relocating personnel from the structure and/or location to the specified emergency withdrawal distance.

*d.* Commanders will develop evacuation plans for their garrisons or installations that reference the appropriate withdrawal distances as part of the disaster response plan. The commander must alert civilian authorities of any explosive accident on the garrison or installation that may affect the local community and provide these authorities with the appropriate emergency withdrawal distances.

#### **6-13. Firefighting guidance symbols**

There are two types of symbols which give guidance for firefighting forces and other personnel, fire and chemical hazard symbols.

*a. Fire divisions.* There are four fire divisions. Fire division 1 indicates the greatest hazard. The hazard decreases as the fire division numbers increase, as shown in table 6-5.

*b. Fire division symbols.* Each of the four fire divisions is indicated by one of four distinctive symbols recognizable to the firefighting personnel approaching the fire scene. The applicable fire division number is shown on each symbol. For easy identification from long range, the symbols differ in shape as shown in table 6-6 and figure 6-1. The hazard and firefighting precautions for each symbol are summarized in table 6-2.

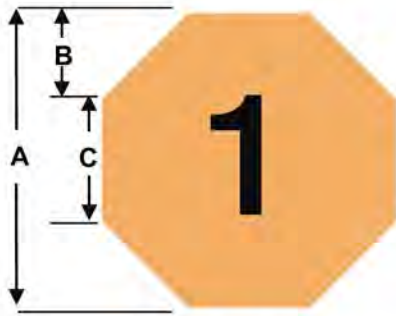

**Fire Symbol 1**  
 Hazard Class 1 Division 1 and 5  
 24" NSN 7690-01-082-0290  
 12" NSN 7690-01-081-9581

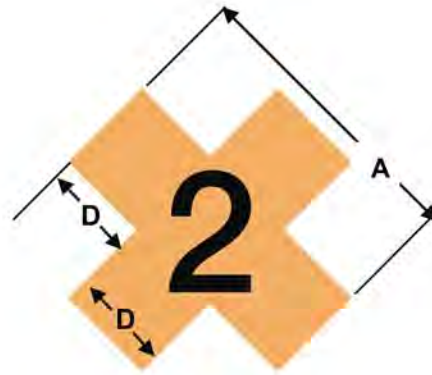

**Fire Symbol 2**  
 Hazard Class 1 Division 2 and 6  
 24" NSN 7690-01-082-0289  
 12" NSN 7690-01-087-7340



**Fire Symbol 3**  
 Hazard Class 1 Division 3  
 24" NSN 7690-01-081-9583  
 12" NSN 7690-01-081-9582



**Fire Symbol 4**  
 Hazard Class 1 Division 4  
 24" NSN 7690-01-082-6709  
 12" NSN 7690-01-081-9584

**Colors** (per Federal Standard 595A and GSA Catalog)  
 Background: Orange #12246 Numbers: Black # 17038

Dimension	Large Symbol (inches)	Small Symbol (inches)
A	24	12
B	7	3.5
C	10	5
D	8	4
Number (height)	10	5
Number (thickness)	2	1

Figure 6-1. Fire symbols

*c. Chemical hazard symbols.* These symbols are used to identify operating buildings and storage facilities which contain pyrotechnic and chemical munitions or agents and other hazardous material.

(1) Hazard symbols vary with the type of filler or bulk chemical composition. These symbols are described in figure 6-2.

(2) The hazard each symbol represents and the firefighting precautions are summarized in figure 6-3.

(3) The APPLY NO WATER sign is intended for use with hazardous materials where use of water may intensify the fire, cause an explosion, or spread the fire.

(4) The chemical agents most used in ammunition and the combinations of chemical hazard symbols required in storage are specified in figure 6-3.



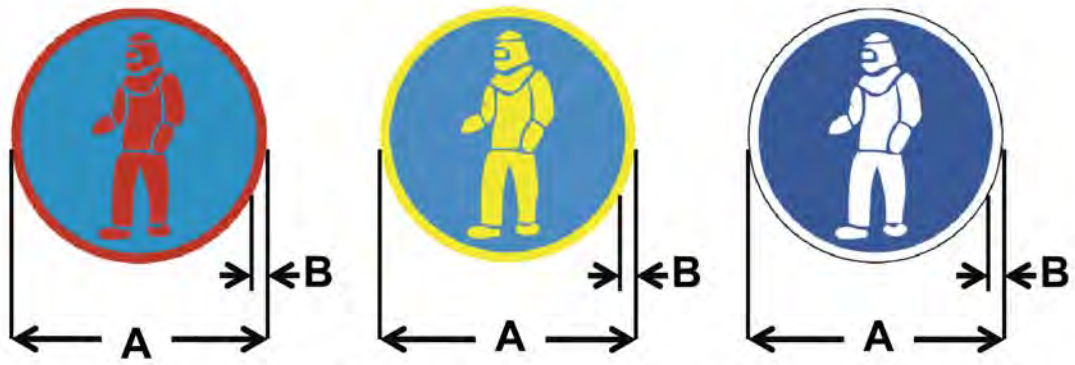

**Symbol 1. Wear full protective clothing.**

Background is blue (#15102). Figure and rim are as follows:

Red (#11105) is for Set 1 Protective Clothing:  
 24 inch: NSN 7690-01-081-9586  
 12 inch: NSN 7690-01-081-9585

Yellow (#13538) is for Set 2 Protective Clothing:  
 24 inch: NSN 7690-01-081-9587  
 12 inch: NSN 7690-01-082-0291

White (#17875) is for Set 1 3 Protective Clothing:

24 inch: NSN 7690-01-083-6272

12 inch: NSN 7690-01-081-9588

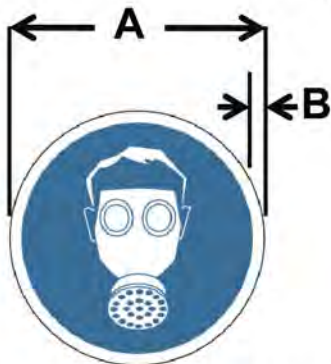

**Symbol 2. Wear breathing apparatus.**

Background is blue (#15102).

Figure and rim are white (#17875).

24 inch: NSN 7690-01-081-9589

12 inch: NSN 7690-01-082-6710



**Symbol 3. Apply no water.**

Background is white (#17875).

Circle and diagonal are red (#11105).

24 inch: NSN 7690-01-082-2254

12 inch: NSN 7690-01-082-0292

Dimension	Large Symbol (inches)	Small Symbol (inches)
A	24	12
B	.5	.25
C	2	1

Figure 6-2. Chemical hazard symbols

Chemical Symbol	Materials (CG)	Hazard	Action/Remarks
Full protective clothing Set 1 (Red)	Nerve or blister agents (K)	Highly toxic as aerosol/vapor	<ol style="list-style-type: none"> <li>1. Evacuate public two miles downwind or one mile upwind or to the sides. These are initial evacuation distances which can and should be modified using an approved evacuation plot program.</li> <li>2. Use munitions decontamination procedures.</li> <li>3. If explosion does not occur, approach from upwind and extinguish fire.</li> </ol>
Full protective clothing Set 2 (Yellow)	Riot control/smokes (G) Incapacitating agents (K)	Toxic as aerosol/vapor	<ol style="list-style-type: none"> <li>1. Approach from upwind and extinguish fire.</li> <li>2. Decontamination may be required.</li> </ol>
Full protective clothing et 3 (White)	TEA smoke (L)	Spontaneously flammable when exposed to air	<ol style="list-style-type: none"> <li>1. Do not look at burning material.</li> <li>2. Do not use water.</li> </ol>
	White Phosphorous (H) and Plasticized White Phosphorous (H)	Spontaneously flammable when exposed to air	<ol style="list-style-type: none"> <li>1. Post fire guard until leaking phosphorous has been removed.</li> <li>2. After removal of agents, post fire guard for two days for possible re-ignition.</li> <li>3. Use putty knife to remove small amounts, then use blowtorch to burn off remainder.</li> </ol>
	Red Phosphorous (G)	Not spontaneously flammable when exposed to air	When exposed to fire red phosphorous can revert to white phosphorous. In this event, use criteria above for white phosphorous.
Wear breathing apparatus	TA/HC smoke (G)	Smoke	Do not use water.
	Incendiary	Burns with extremely high temperatures	<ol style="list-style-type: none"> <li>1. Do not use water.</li> <li>2. Do not look at burning material.</li> </ol>
	Napalm (J)	Mass fire	Fight as a POL fire.
Apply no water	HC smoke (G)	Smoke	Do not use water
	Incendiary	Burns with extremely high temperature	<ol style="list-style-type: none"> <li>1. Do not use water.</li> <li>2. Do not look at burning material.</li> </ol>
	TEA smoke (L)	Spontaneously combustible	<ol style="list-style-type: none"> <li>1. Do not use water.</li> <li>2. Do not look at burning material.</li> </ol>

Figure 6-3. Chemical hazards symbols and actions

d. *Posting symbols.* Symbols will be removed, covered, or reversed if the explosives or chemical agents are removed from a facility or location. The person in charge of the operation will post or change the symbols. The fire department will be notified each time fire or hazard symbols are changed.

e. *Symbol dimensions.* The dimensions shown in figures 6-1 and 6-2 are the normal minimum sizes. Half-size symbols may be used where appropriate, for example, on doors and lockers inside buildings.

f. *Obtaining symbol decals.* Decals for fire and chemical hazard symbols may be requisitioned through the Defense Logistics Agency. National stock numbers of standard and half-size decals are listed in figures 6-1 and 6-2.

g. *Storing toxic chemical and ammunition items.* Toxic chemicals without explosive components may be received as

Class 6, Division 1 poisons (6.1). Items which contain chemical substances of another commodity class and which do not contain explosive components, may be stored with ammunition items containing explosives and the same chemical substance.

#### **6-14. Posting fire symbols**

The fire symbol that applies to the most hazardous material present will be posted on or near all nonnuclear explosives locations. It will be visible from all approach roads. One symbol posted on or near the door end of an earth-covered magazine is normally enough. One or more symbols may be needed on other buildings. When all munitions within a storage area are covered by one fire symbol, it may be posted at the entry control point.

- a. When different HDs of explosives are stored in individual multi-cubicle bays or module cells, they shall be further identified by posting the proper fire symbol on each bay or cell.
- b. Where facilities containing explosives are located in a row on one service road and require the same fire symbol, only one fire symbol at the entrance of the row is required.
- c. Fire symbols will be placed on entrances to arms rooms containing ammunition. Where explosives are stored in a locker or similar container, the container will also be marked with the appropriate fire symbol. Symbols are not required on the exterior of the building, providing the building is exempt from QD in accordance with provisions of this pamphlet.

#### **6-15. Exceptions on posting fire symbols**

- a. Fire symbols need not be posted on locations having 1,000 rounds or less of HD 1.4 small arms ammunition (.50 caliber or less).
- b. Use the symbols in this regulation unless host nation symbols differ and, by agreement, host nation symbols are required.
- c. The responsible commander may, for security purposes, remove symbols. In such situations the commander will emphasize giving prompt and exact information to the fire department about changes in the status of explosives.
- d. Storage of explosives at FUDS sites may be exempt, unless mandated by local fire officials.
- e. If vehicles or aircraft are in a designated explosives parking area, fire symbols need not be posted if such areas are described in a local publication, such as the vehicles and aircraft parking plan, which includes the following:
  - (1) The HD involved.
  - (2) The governing fire symbol for the parking area.
  - (3) Procedures to be followed during an emergency.
  - (4) The requirement to notify the fire department.

#### **6-16. Posting chemical hazard symbols**

- a. If chemical or pyrotechnic munitions are assembled with explosive components, then chemical hazard symbols must be used together with fire division symbols. Chemical munitions, which do not have explosive components, will be identified by the chemical hazard symbol only.
- b. Requirements for posting hazard symbols are similar to those for posting fire symbols.
- c. Chemical symbols must be removed, covered, or reversed as soon as chemical agents are removed from a location.

#### **6-17. Procedures for chemical agents and other toxic substances**

These procedures vary according to the type of agent involved and are summarized in figure 6-3.

#### **6-18. Automatic sprinkler systems**

a. Properly installed and maintained automatic sprinkler protection is important in reducing fire losses and is justified in certain buildings. In addition to requirements of the National Fire Codes, published by the NFPA, the following are examples of locations where sprinklers will be installed when required by AR 420-1:

- (1) In certain buildings, in load lines, explosives manufacturing, receiving, shipping, inspection, ammunition workshop, and demilitarization areas after a risk assessment.
- (2) Where a potential loss of life exists.
- (3) When value of buildings and/or contents warrants.

b. Automatic sprinkler systems will not be deactivated unless repairs or modification to the system are required. When interruption is required or deactivation of a system is necessary, the criteria and precautions outlined in UFC 3-600-02 will be followed. Where heating is a problem, wet systems should be converted to automatic dry systems. Valve rooms will be heated during the winter.

- c. Inspection and maintenance of automatic sprinkler systems will conform to requirements of UFC 3-600-02.
- d. Local water flow alarm facilities are required for automatic sprinkler systems installed in explosives operating buildings; however, transmitted water flow alarms may not be required.

## 6-19. Deluge systems for explosives operations

*a.* In addition to sprinklers, deluge systems will be provided to protect operating personnel in high hazard occupations and locations where a process fire hazard exists. An ultra high speed deluge system will be considered when the following conditions exist—

- (1) A risk assessment indicates that an accidental deflagration or explosion is unacceptable.
- (2) An area or operation will expose personnel to thermal flux in excess of 0.3 calories per square centimeter per second if an accidental deflagration or explosion should occur.
- (3) The system must be capable of preventing propagation between bays and preventing significant injury to employees. Quick-acting sensors such as ultraviolet (UV) or infrared (IR) detectors will be used. The ACOM, ASCC, or DRU may approve using new technology which offers comparable or better protection than UV or IR detectors. The deluge valve will be arranged for automatic and/or manual activation.

*b.* An ultra high-speed deluge system is an instantaneous response (milliseconds) system. It is used primarily to protect personnel, process equipment, and buildings from the fire and thermal hazard presented by energetic material involved in high hazard explosive operations, such as, melting, mixing, blending, screening, sawing, granulating, drying, pressing, extrusion, and pouring. Deluge systems with heat-actuated devices (HAD) are not ultra high speed deluge systems and will not be used for personnel protection.

*c.* Due to the speed of water coming from all the nozzles, ultra high-speed deluge systems depend on the detection system, piping network, nozzles and water supply characteristics. Only experienced designers, engineers, and installers who understand the system's limitations and capabilities should provide the design, specification, and installation of the deluge system.

*d.* All munitions production, maintenance, renovation, quality assurance and demilitarization operations will receive a risk assessment to identify potential fire and thermal threats and to assess the level of risk. The hazard must be accurately defined. A potential fire and or thermal hazard whose level of risk is high or extremely high must be accepted at the appropriate level of command in accordance with DA Pam 385-30. The risk assessment will consider factors such as:

- (1) Initiation sensitivity.
- (2) Quantity of material.
- (3) Heat output.
- (4) Burning rate.
- (5) Potential ignition and initiation sources.
- (6) Protection capabilities.
- (7) Personnel exposure.
- (8) Munitions configuration.
- (9) Process equipment.
- (10) Process layout.
- (11) The building layout.

*e.* The diameter, length, number of bends, and friction coefficient limits the effective flow rate of the water that the system can transport at an effective pressure. Pipe runs will be kept to a minimum. Horizontal runs will be sloped at least 1/4 inch per 10 feet of run, with air bleeder's at all high points. The looping of deluge piping systems may improve response time by improving pressure and effective flow rate.

*f.* The design of the nozzle orifice determines the dispersion pattern, water droplets, and turbulence of the water flow which in turn, directly affects the water velocity. Nozzles will be installed with priming water being held back at the nozzle with blowoff caps, rupture disc, or the poppet valve when utilizing pilot operated nozzles. Nozzle discharge rates and spray patterns will be selected to meet the hazard condition being protected.

*g.* The nozzles will be located as close to the exposed surface of the explosives as possible to ensure immediate drenching of all parts of the machine or operation under extreme conditions. The discharge pattern of the nozzle can be used in determining the required distance. When explosives are located inside machines under tight hoods or covers, distributing outlets will be located inside the enclosed space.

*h.* Where explosive vapors, gases, or dusts may enter outlets and interfere with their operation, nonmetallic internally spring- held caps will be placed on the outlets. The design must provide immediate release of the cap when pressure is exerted within the outlet. Caps will be attached to outlets with small nonferrous chains to prevent their loss when the deluge system is activated.

*i.* Install a device on the supply side of the system so that the system will actuate an audible warning device in affected operating areas when the pressure falls.

*j.* Deluge systems will be charged with water or chemicals. This depends on the character of the fire to be controlled, as determined by engineering studies of the hazards and the hazard analysis.

*k.* Operations protected by a deluge system will be stopped immediately if the system fails and will not be resumed without adequate protection.

*l.* An estimate of the required maximum flow rate and pressure will be made. The capabilities of the existing water

supply and distribution system to meet these requirements will be evaluated. If the required flow rate and pressure is not adequate, arrangements must be made to provide the required flow and pressure. The water pressure necessary for proper functioning of a deluge system must be available instantaneously. The water supply will have duration of at least 15 minutes. If there are two or more deluge systems in the same fire area, supply mains and the arrangements and size of the system rise will provide each system with the required quantities of water per head. No allowance is required for hose lines. All valves on water lines between the water main and the deluge systems will be supervised to ensure the valves are not accidentally closed.

*m.* The deluge valve will be arranged for automatic or manual activation or both. At a minimum, manual activation devices will be located at exits.

*n.* The deluge system must be able to prevent fire spreading from one cell or bay to another. Together with personal protective equipment required for workers at the operation, the deluge system will prevent significant injury to the worker. The workers will not receive more than first-degree burns from any thermal threat. The effectiveness of the deluge system will be demonstrated by test against actual or equivalent threat. These tests will be conducted with the maximum quantity of energetic material expected to be in the cell or bay. Testing is unnecessary if a small deluge (design flow of 500 gallons per minute or less) has a response time of 100 milliseconds. Testing is unnecessary for a large deluge system (design flow of more than 500 gallons per minute) with a response time of 200 milliseconds or less, provided a hazard analysis indicates that a faster response time is not required. For the life of the system, the garrison or installation will retain on file the results of the tests or the use of the 100 or 200 milliseconds or less response time.

*o.* Response time is the time in milliseconds from the presentation of an energy source to the detection system, to the beginning of water flow from the critical nozzle under test. The critical nozzle is usually located closest to the hazard or as a hazard analysis determines best.

*p.* Two methods are commonly used to measure response time—

(1) A millisecond digital time is started by saturated UV source (IR for IR detectors) held directly in front of the detector and is stopped by the actuation of a water flow switch at the critical nozzle. This method does not measure the time lag of and water travel time from the nozzle to the target. It is normally used for routine testing.

(2) A high-speed video camera and recorder (at least 120 frames per second) can be used for very accurate measurement. The time from ignition to detection and water travel time from nozzle to target can also be measured. The video recording system can be used for contract compliance or when measurement of total response time is required.

*q.* Deluge systems will be tested and maintained per the criteria of UFC 3–600–02 ([http://www.wbdg.org/ccb/DOD/UFC/ufc\\_3\\_600\\_02.pdf](http://www.wbdg.org/ccb/DOD/UFC/ufc_3_600_02.pdf)) and this pamphlet. A good preventive maintenance program is required to reduce the number of false alarms and other system problems. Systems in laid-away or inactive facilities are exempt from testing. Laid-away systems will be tested when they are put back into service. Records of tests will be kept on file at the garrison or installation. The following tests will be conducted:

(1) A full operational flow test will be conducted at intervals not to exceed 1 year, including measurement of response time. The garrison or installation will retain the results of tests on file for the life of the system.

(2) Detectors will be tested and inspected for physical damage and accumulation of deposits on the lenses at least monthly.

(3) Controllers will be checked at the start of each shift for any faults.

(4) Valves on the water supply line shall be checked at the start of each shift to ensure that they are open. Checking is unnecessary if the valve is secured in the “open” position with a locking device or is monitored by a signaling device that will sound a trouble signal at the deluge system control panel or other central location.

*r.* The melt kettle and closed containers of molten explosive will normally not be equipped with internal flame detectors or deluge nozzles. The exterior of the kettles and closed containers will be protected by ultra-high-speed deluge systems. This is especially important for container or kettle openings where materials are placed.

*s.* Other types of ultra high-speed deluge systems may be used, if they provide the level of protection required by this standard. Two nontraditional deluge systems are currently available. This does not preclude the use of other type ultra high-speed deluge systems.

(1) The portable deluge system is a transportable self-contained ultra high-speed deluge system. The system uses multiple optical fire detectors, multiple nozzles, and a pressurized water tank (minimum 100 gallons of water). Response time must not exceed 100 ms as outlined above. Test the response time when the system is set up for a new operation. Locate the system so no personnel work directly opposite it. The portable system is intended to protect short-term ammunition operations. It is not a permanent solution for long-term runs or high usage locations. Before using the portable deluge system, prepare a hazard analysis. It must address hazard being protected, the ability of the portable system to provide the required level of protection, the need for a backup fire protection system or backup water supply, and mitigating factors.

(2) The pressurized sphere deluge system is a small self-contained system. The system uses multiple optical fire detectors and at least one high pressurize water sphere (typically 10 to 30 liters) with a rupture disc and internal squib. Response time must not exceed 10 ms as outlined above. The sphere discharges water via a rupture disc. A screen

breaks the water into small-atomized particles and collection of residual squib fragments. There should be at least 36 inches between the bottom of the sphere and the heads of operators. The sphere system is designed as a standalone unit for small quantities of energetic materials. For larger quantities of energetic materials use a backup fire protection system (for example, conventional ultra high-speed deluge system, heat-activated system, or automatic sprinkler with quick response heads). Before using the sphere system, prepare a hazard analysis. It must address hazard being protected, the ability of the sphere system to provide the required level of protection, the need for a backup fire protection system, and other mitigating factors. (NOTE: Extensive test data is available.)

*t.* The required density will depend upon the type of energetic material involved, process layout, and whether the aim is to extinguish the fire, prevent its propagation, or prevent serious injury, or a combination of these. A commonly used density for preventing propagation and structural damage is 0.5 gallons per minute (GPM)/ft<sup>2</sup>. To protect personnel and process equipment or extinguish pyrotechnic materials, significantly higher density rates may be necessary. These may be as high as 3.0 GPM/ft<sup>2</sup> for area coverage or 200 GPM for point-of-operation coverage.

## 6–20. Emergency planning

Garrisons or installations or responsible activities will develop Standing Operating Procedures (SOPs) or plans designed to provide safety, security, and environmental protection. Plans will be coordinated with the appropriate Federal, state, and local emergency response authorities (such as, law enforcement, fire departments, and hospitals) and any established Local Emergency Planning Committees (LEPCs). At a minimum, these SOPs or plans shall include—

*a.* Specific sections and guidance that address emergency preparedness, contingency planning, and security. With respect to security, these SOPs or plans will include provisions that limit access to trained and authorized personnel.

*b.* Procedures that minimize the possibility of an unpermitted or uncontrolled detonation, release, discharge, or migration of military munitions or explosives out of any storage unit when such release, discharge, or migration may endanger human health or the environment.

*c.* Provisions for prompt notification to emergency response and environmental agencies and the potentially affected public in the event of an actual or potential detonation or uncontrolled release, discharge, or migration that may endanger human health or the environment.

*d.* Provisions for complying with the Emergency Planning Community Right-To-Know Act (EPCRA), Section 302–312 and DOD or DA implementing policies.

*e.* Tables 6–1 through 6–6 show extinguishing agents for fires, fire symbol hazards and actions, chemical hazards symbols and action, emergency withdrawal distances for nonessential personnel, fire divisions and associated hazards, fire division symbols and chemical agents and fillers contained in ammunition and the chemical hazard symbols required in storage.

**Table 6–1**  
**Extinguishing agents for fires**

Type of Fire	Extinguishing agent
Class A - Combustible (materials such as wood, paper, rubbish, or grass)	Water
Class B - Volatile flammables (materials such as oil, gasoline grease, or paint)	Carbon dioxide, FM–200, foam, or dry chemical
Class C - Electrical (electrical equipment)	Carbon dioxide, FM–200, or dry chemical
Class D - Combustible metals (magnesium, potassium, and so forth)	Dry powder

Notes:

<sup>1</sup> This is general guidance. For more specific guidance, see MSDS, NFPA publications, or consult a fire protection specialist.

**Table 6–2**  
**Fire symbol hazards and actions**

Fire symbol	Materials	Hazard	Action/remarks
1	1.1 explosives, ammunition, and liquid propellants	Mass detonation	1. Will not be fought unless a rescue attempt is being made. 2. If there is suitable separation between nonexplosive and symbol 1 material, and if approved by the fire chief, fire fighting forces may attempt to extinguish the fire. 3. If personal safety is in doubt, take suitable cover.
2	1.2 ammunition and explosives	Explosion with fragments	1. Give the alarm and attempt to extinguish the fire if in an early stage. 2. Firefighting forces should fight the fire, until the explosive material becomes involved in the fire or the fire chief determines the risk is too great. If not possible, prevent the fire from spreading. 3. Detonations of items could occur. Provide protection from fragments.
3	1.3 ammunition and explosives	Mass fire	1. May be fought if explosives not directly involved. 2. If WP munitions are involved, smoke is liberated. WP munitions may explode. WP should be immersed in water or sprayed with water continuously. 3. For fire involving HC and incendiaries, water should not be used unless large quantities are available. Use dry sand and/or dry powder agent in the early stage. 4. For fires involving pyrotechnics and magnesium incendiaries, protect adjacent facilities and equipment. Do not use CO <sub>2</sub> or water on or near the munitions. Allow magnesium to cool unless upon flammable material. In this case, use a 2-inch layer of dry sand or powder on the floor and rake the burning material onto this layer and smother.
4	1.4 ammunition and explosives	Moderate fire	1. Fight the fires. 2. Expect minor explosions and hot fragments.

**Table 6–3**  
**Emergency withdrawal distances for nonessential personnel**

Hazard class/division	Unknown quantity NEW	Known quantity NEW
Unknown, located in facility, truck and/or tractor trailer	4,000 feet (approximately .75 mile)	4,000 feet (approximately .75 mile)
Unknown, located in railcar	5,000 feet (approximately one mile)	5,000 feet (approximately 1 mile)
HD 1.1 (see note 1)	Same as unknown HD	For transportation: (a) Use 2,500 feet minimum distance for NEW > 500 lbs. (b) Use 5,000 feet minimum distance for railcards with NEW < 500 lbs and 4,000 feet for other modes. (c) Use 4,000 feet minimum distance for bombs and projectiles with caliber 5 inch (127 mm) and greater (d) (e) For facilities: a. Use 2,500 feet minimum distance for NEWQD > 15,000 lbs. b. Use 4,000 feet minimum distance for NEWQD > 15,000 lbs and 50,000 lbs or less. (f) Above 50,000 lbs, use $D=105 W^{1/3}$ .
HD 1.2 (See note 1.)	2,500 feet	2,500 feet
HD 1.3 (See note 2.)	600 feet	Twice the IBD distance with a minimum distance of 600 feet
HD 1.4	300 feet	300 feet

Notes:

<sup>1</sup> For HD 1.1 and 1.2 items, if known, the maximum range fragments and debris will be thrown (including the interaction effects of stacks of items, but excluding lugs, strongbacks, and/or nose and tail plates) may be used to replace the withdrawal distances of table 6–4.

<sup>2</sup> For accidents involving propulsion units, it is unnecessary to specify emergency withdrawal distances based upon the potential flight ranges of these items.

**Table 6-4**  
**Fire divisions and associated hazards**

Fire division	Hazard involved
1	Mass detonation
2	Explosion with fragments
3	Mass fire
4	Moderate fire

**Table 6-5**  
**Fire division symbols**

Fire symbol	Shape	National stock number
1	Octagon	7690-01-082-0290 7690-01-081-9581
2	X	7690-01-082-0289 7690-01-087-7340
3	Inverted triangle	7690-01-081-9583 7690-01-081-9582
4	Diamond	7690-01-082-6709 7690-01-081-9584

**Table 6-6**  
**Chemical agents and fillers contained in ammunition and the chemical hazard symbols required in storage**

Chemical Agents and Fillers contained in ammunition	Full Protection Clothing (symbol 1)			Breathing Apparatus (symbol 2)	Apply no water (symbol 3)	GB	H	L	VX
	SET 1	SET 2	SET 3						
GB	X					X			
H, HD, HT	X						X		
L	X							X	
VX	X								X
CL, CG, CK, CN, CNS, CS, CR, BBC DA, DC, DM, FS, FM		X							
HC				X	X				
TA				X					
WP, PWP, RP			X						
TH, PT				X	X				
IM, NP				X					
TEA, TPA			X		X				
COLORED SMOKES				X					

## Chapter 7 Hazard Classification and Compatibility Groups

### 7-1. Explosives hazard classification procedures

All AE must be hazard classified prior to transportation or storage. Joint TB 700-2 (see <http://www.ddesb.pentagon.mil>) contains procedures for identifying and classifying AE hazards. Items without a final hazard classification require



an interim hazard classification (IHC). IHCs are valid for transportation for up to 1 year. IHC renewals for transportation require a request for justification for the continued need. Army IHCs are valid for storage indefinitely worldwide.

## 7-2. Storage principles

*a.* The highest degree of safety in ammunition and explosives storage could be assured if each item were stored separately. However, such ideal storage generally is not feasible. A proper balance of safety and other factors frequently requires mixing of several types of ammunition and explosives in storage.

*b.* Ammunition and explosives may not be stored together with dissimilar materials or items that present additional risks unless they have been assessed to be compatible. Examples are mixed storage of ammunition and explosives with flammable or combustible materials, acids, or corrosives. Non-regulated AE and AE assigned to classes 2 through 9 may have a compatibility group (CG) assigned. When so assigned, the AE may be stored in an explosives magazine in accordance with the CG. The explosive weight of non-regulated AE and AE assigned to classes 2 through 9 is not considered for QD purposes.

*c.* If different types of CG N munitions are mixed together and have not been tested to ensure non-propagation, the mixed munitions types are individually considered to be HD 1.2.1D or HD 1.2.2D based on their NEWQD or overriding fragmentation characteristics.

*d.* All ammunition and explosives items are assigned to one of 13 storage compatibility groups based on the similarity of characteristics, properties, and accident effects potential (see table 7-1). Items in each CG can be stored together without significantly increasing either the probability of an accident or, for a given quantity, the magnitude of the effects of such an accident. Considerations used in assigning CGs include but are not limited to the following:

- (1) Chemical and physical properties
- (2) Design characteristics
- (3) Inner and outer packing configurations
- (4) Quantity-distance division
- (5) Net explosive weight
- (6) Rate of deterioration
- (7) Sensitivity to initiation
- (8) Effects of deflagration, explosion, or detonation.

*e.* When such mixed storage will facilitate safe operations and promote overall storage efficiency, ammunition and explosives may be mixed in storage, provided they are compatible. Assignment of items of CGs requiring separate storage will be minimized consistent with actual risks presented and not based on administrative considerations or end use.

*f.* Ammunition and explosives in substandard or damaged packaging, in a suspect condition, or with characteristics that increase the risk in storage will be stored separately.

## 7-3. Mixed storage

*a.* Table 7-2 shows how different CGs of ammunition and explosives can be mixed in storage. Exceptions are listed in paragraph 7-3b, below.

*b.* Certain locations within the United States, its territories, and possessions designated by the Army and with site approval from the DDESB to store ammunition in rapid response configurations and Basic Load Ammunition Holding Areas (BLAHA) outside the United States are authorized to store ammunition without regard to compatibility. The maximum NEQ at any of these locations storing mixed compatibility ammunition must not exceed 4000 kg (8820 pounds NEW) calculated in accordance with paragraph 9-4c of this pamphlet. AE of different CG may only be mixed in storage as indicated in table 7-2. The exceptions are when chapter 9 is being applied, and at specific CONUS locations that the Army designates to store AE packaged and configured for rapid response (for example, Rapid Deployment Force) for which the DDESB has approved the site plan. Such designated locations are authorized to mix CG without complying with the compatibility and mixing requirements, as operationally required to achieve the optimum load needed by the intended receiving troops. The maximum credible event allowable at any of these storage sites shall be limited to 8,820 lbs NEWQD (4,000 kg NEQ). When computing QD requirements for such sites, chapter 8 applies. However, the following AE will be excluded for NEWQD determination at such storage sites:

- (1) Propelling charges in HD 1.2 fixed, semi-fixed, mortar, and rocket AE.
- (2) The NEWQD of HD 1.3 items, except at sites that contain only HD 1.3 items. At such sites, HD 1.3 QD applies. (Note: In the application of this paragraph to separate loading AE, the explosive weights of propelling charges are generally excluded when matched pairs of projectiles and propelling charges are at the site. However, if the quantity of propelling charges at the site exceeds the maximum usable for the quantity of projectiles at the site, the explosives weights of all propelling charges and projectiles at the site must be summed for NEWQD determination.)

c. Complete round storage concept (near equal numbers of projectiles, propellant, fuzes, and primers) is acceptable for locations OCONUS where rapid response is essential.

#### 7-4. Compatibility groups

a. *Assignment.* Ammunition and explosives are assigned to one of 13 CGs as follows in table 7-1.

Group	Description	Type Ammo/Explosive
<b>A</b>	Bulk initiating explosives that have the necessary sensitivity to heat, friction, or percussion to make them suitable for use as initiating elements in an explosives train.	Wet lead azide, wet lead styphnate, wet mercury fulminate, wet tetracene, dry cyclonite (RDX), and dry pentaerythritol tetranitrate (PETN).
<b>B</b>	Detonators and similar initiating devices not containing two or more independent safety features. Items containing initiating explosives that are designed to initiate or continue the functioning of an explosives train.	Detonators, blasting caps, small arms primers, and fuzes.
<b>C</b>	Bulk propellants, propelling charges, and devices containing propellant with or without their own means of ignition. Items that, upon initiation, will deflagrate, explode, or detonate.	Single-, double-, triple-base and composite propellants, rocket motors (solid propellant), and ammunition with inert projectiles.
<b>D</b>	Black powder, high explosives (HE), and ammunition that contain HE without its own means of initiation and without propelling charge, or a device containing initiating explosives and containing two or more independent safety features. Ammunition and explosives that can be expected to explode or detonate when any given item or component thereof is initiated except for devices containing initiating explosives with independent safety features.	Bulk trinitrotoluene (TNT), Composition B, black powder, wet RDX or PETN, bombs, projectiles, cluster bomb units (CBUs), depth charges, and torpedo warheads.
<b>E</b>	Ammunition or devices containing HE without its own means of initiation and containing propelling charges (other than one containing a flammable or hypergolic liquid).	Artillery ammunition, rockets, or guided missiles.
<b>F</b>	Ammunition containing HE with its own means of initiation and with propelling charge (other than one containing a flammable or hypergolic liquid) or without a propelling charge.	Grenades, sounding devices, and similar items having an in-line explosives train in the initiator.
<b>G</b>	Fireworks, illuminating, incendiary, and smoke, including hexachloroethane (HC) or tear-producing munitions other than those munitions that are water activated or which contain white phosphorous (W/P) or flammable liquid or gel. Ammunition that, upon functioning, results in an incendiary, illumination, lachrymatory, smoke, or sound effect.	Flares, signals, incendiary or illuminating ammunition, and other smoke or tear-producing devices.
<b>H</b>	Ammunition containing both explosives and WP or other pyrophoric material. Ammunition in this group contains fillers which are spontaneously flammable when exposed to the atmosphere.	Plasticized white phosphorous (PWP), or other ammunition containing pyrophoric material.
<b>J</b>	Ammunition containing both explosives and flammable liquids or gels (other than those which are spontaneously flammable when exposed to water or the atmosphere).	Liquid- or gel-filled incendiary ammunition, fuel-air explosives (FAE) devices, flammable liquid-fueled missiles, and torpedoes.
<b>K</b>	Ammunition containing both explosives and toxic chemical agents. Ammunition in this group contains chemicals specifically designed for incapacitating effects more severe than lachrymation.	Artillery or mortar ammunition (fuzed or unfuzed), grenades, and rockets or bombs filled with a lethal or incapacitating chemical agent.
<b>L</b>	Ammunition and explosives not included in other compatibility groups. Ammunition or explosives having characteristics that do not permit storage with other types of ammunition or kinds of explosives or dissimilar ammunition of this group. Note: Ammunition/explosives presenting same or similar risks within this group may be stored together. However, items with dissimilar risks within this group must be kept separate and apart from all other items.	Water-activated substances, phosphides, and pyrophoric substances and devices containing these substances; hypergolics and hypergolic prepackaged liquid - fueled rocket engines; TPA (thickened TEA) and damaged or suspect ammunition of any group.
<b>N</b>	Ammunition containing only extremely sensitive detonating substance (EIDS). Note: If dissimilar Group N munitions are mixed together and have not been tested to assure non-propagation, then the mixed munitions are considered to be Hazard Division 1.2, compatibility Group D for purposes of transportation and storage.	Bombs and warheads

**Table 7-1**  
**Storage compatibility groups—Continued**

<b>S</b>	Ammunition presenting no significant hazard. Ammunition so packaged or designed that any hazardous effects arising from accidental functioning are confined within the package unless the package has been degraded by fire, in which case all blast or projection effects are limited to the extent that they do not hinder firefighting or other emergency response efforts in the immediate vicinity (for example, 5 meters) of the package.	Thermal batteries, explosives switches or valves, and other ammunition items packaged to meet the criteria of this group.
----------	---	---

*b. Means of initiation.* As used in this standard, the phrase “with its own means of initiation” indicates that the ammunition has its normal initiating device assembled to it, and this device would present a significant risk during storage. However, the phrase does not apply when the initiating device is packaged in a manner that eliminates the risk of causing detonation of the ammunition if the initiating device functioned accidentally, or when fuzed end items are configured and packaged to prevent arming of the fuzed end items. The initiating device may be assembled to the ammunition provided its safety features preclude initiation or detonation of the explosives filler of the end item during an accidental functioning of the initiating device.

**7-5. Extremely insensitive detonating substance and ammunition**

*a.* EIDS is comprised of substances which have a mass explosion hazard but are so insensitive that there is very little probability of initiation or of transition from burning to detonation under normal conditions of transport. These materials are assigned to HD 1.5 for transportation purposes only. For storage, these materials are assigned to HD 1.1.

*b.* EIDS ammunition consists of extremely insensitive articles that do not have a mass explosive hazard. The articles contain only EIDS and demonstrate (through test results) a negligible probability of accidental initiation or propagation. These materials are assigned HD 1.6.

*c.* Quantity-distance (QD) application:

- (1) QD separation for HD 1.6 ammunition and explosives will be based on table 7-3.
- (2) Inhabited building distance for bulk HD 1.6 explosives will be in accordance with table 8-26.

**7-6. Class 1 or 6 chemical agent hazards or combined chemical agent and explosives hazards**

*a.* Items in these classes are chemical agent-filled ammunition, chemical agents, and chemical agent-filled components. Depending upon the type of agent, its persistency, toxicity, or other characteristics, the primary safety considerations may be the area of agent dispersal rather than blast or fragment considerations.

*b.* Items that contain only toxic chemical components are assigned to HD 6.1. Items that contain both explosives and toxic chemical components are included in UN Class 1, ammunition and explosives, as appropriate. HD 6.1 requirements also shall be applied so that the explosives and toxic chemical hazards both are considered.

**7-7. Underground storage**

Ammunition with smoke producing, incendiary, flammable liquid or toxic chemical agent fillers may be stored in single chamber underground facilities but shall not be stored in multi-chamber facilities. Other than this restriction, ammunition and explosives of all compatibility groups may be placed in underground storage in compatible combinations as permitted above.

**Table 7-2**  
**Storage compatibility mixing chart**

Group	A	B	C	D	E	F	G	H	J	K	L	N	S
A	X	Z											
B	Z	X	Z	Z	Z	Z	Z					X	X
C		Z	X	X	X	Z	Z					X	X
D		Z	X	X	X	Z	Z					X	X
E		Z	X	X	X	Z	Z					X	X
F		Z	Z	Z	Z	X	Z					Z	X
G		Z	Z	Z	Z	Z	X					Z	X
H								X					X
J									X				X
K										Z			

**Table 7-2**  
**Storage compatibility mixing chart—Continued**

<b>L</b>													
<b>N</b>		X	X	X	X	Z	Z					X	X
<b>S</b>		X	X	X	X	X	X	X	X			X	X

Notes:

<sup>1</sup> "X" indicates that these groups may be combined in storage; otherwise, mixing is either prohibited or restricted according to note #2. A "Z" at an intersection indicates that when warranted by operational considerations or magazine non-availability, and when safety is not sacrificed, mixed storage of limited quantities of some items from different groups may be approved in writing. Approval of such storage will be at a level consistent with the risk acceptance authority criteria of DA Pam 385-30, table 4-2; however, a DA Form 7632 (Certificate of Risk Acceptance) is not required. Documentation of this approval must be kept on hand by the installation or garrison safety office. Mixed storage of items within groups where no X or Z exists at that pair's intersection beyond the prohibitions and limitations of note 7 below: however, requires a Certificate of Risk Acceptance per DA Pam 385-30. USATCES shall determine which items may be stored with Group K. Group K may also require separate storage within the group. Articles of compatibility Groups B and F shall each be segregated in storage from articles of other compatibility groups by means that are effective in preventing propagation of those articles through fire or detonation (a sand bag wall at least one foot thick and high enough to prevent line of sight exposure will provide this protection). Examples of acceptable storage combinations are: (a) HD 1.1A initiating explosives with HD 1.1B fuzes not containing two or more effective protective features; (b) HD 1.3C bulk propellants or bagged propelling charges with HD 1.3G pyrotechnic substances.

<sup>2</sup> Compliance with compatibility criteria is not required for mission essential or operationally necessary quantities of explosives in class/division 1.4 or 6.1 (excluding toxic chemical munitions); up to 100 lbs. NEW class/division 1.3; and up to 50 lbs. NEW Class/Division 1.2.2. See paragraph 8-2b for QD requirements and additional information concerning small quantities of explosives.

<sup>3</sup> Equal numbers (to the nearest pack or pallet as applicable) of separately packaged components of complete rounds of any single type of ammunition may be stored together. When so stored, compatibility is that of an assembled round, for example, WP filler in Group H, HE filler in Groups D, E, or F, as appropriate

<sup>4</sup> Ammunition items without explosives that contain substances properly belonging to another U.N. hazard class may be assigned to the same compatibility group as items containing explosives and the same substance, and be stored with them.

<sup>5</sup> DA may authorize ammunition designated 'practice' by National Stock Number (NSN) and nomenclature to be stored with the fully loaded ammunition it simulates.

<sup>6</sup> In addition to the authority in paragraph 7-4b, above, and Z compatibility storage in Note 2 above, the ACOM, ASCC, or DRU may also authorize the mixing of compatibility groups in quantities not exceeding 1000 pounds NEW per storage site; EXCEPT items in Groups A, K, and L.

<sup>7</sup> For purposes of mixing, all items must be packaged in approved storage/shipping containers. Items shall not be opened for purposes of issuing unpackaged munitions in storage locations. Outer containers may be opened in storage locations for inventorying; for removing munitions still inside an approved inner package in limited amounts, and for magazines storing only hazard division 1.4 items, unpacking, inspecting, and repacking the hazard division 1.4 ammunition.

<sup>8</sup> If dissimilar CG N munitions are mixed together and have not been tested to ensure non-propagation; the mixed munitions are considered to be HD 1.2, CG D for purposes of transportation and storage. When mixing CG N munitions with CGs B through G, see paragraph 8-7 about changing QD class/divisions.

<sup>9</sup> For storage purposes, fuzes assigned to CG D are also compatible with fuzes assigned to CG B.

**Table 7-3**  
**Extremely insensitive detonating substance ammunition hazard divisions**

Type	QD HD CG
EIDS bulk	1.5D
EIDS loaded projectiles and/or warheads w/o fuzes or with EIDS fuzes <sup>1,2</sup>	1.6N
EIDS fuzes 1	1.4D
EIDS loaded projectiles and/or warheads w/1.3 propelling charges and without fuzes or with EIDS fuzes <sup>1,2</sup>	1.3C/1.2C
EIDS loaded projectiles and/or warheads with non-EIDS fuzed and without 1.3 propelling charges	1.2D <sup>3,4</sup>
EIDS loaded projectiles and/or warheads with non-EIDS <sup>2,4</sup> fuzes and with 1.3 propelling charges	1.2E <sup>3,4</sup>

Notes:

<sup>1</sup> EIDS fuzed means that the fuze has an EIDS booster with an out-of-line non-EIDS explosive and two or more independent safety features. The fuze must be certified as invulnerable to accidental detonation of the warhead.

<sup>2</sup> Fuzed configuration must be tested for propagation.

<sup>3</sup> Unit risk may be justified on a case-by-case basis.

<sup>4</sup> Fuze must have two or more independent safety features and be independently classified group D.

**Table 7-4**  
**Quantity-distance criteria for configuration of hazard division 1.6 components and assemblies with other hazard division components**

Location	Explosives	Ammunition		
Bulk	Non-EIDS fuzed <sup>2</sup>	Unfuzed or with EIDS fuzed <sup>2,4</sup>		
With or without 1.3 propelling charge	With 1.3 propelling charge	Without 1.3 propelling charge		
Earth-covered magazine	Div 1.3	Div 1.2 <sup>3</sup>	Div 1.3	Div 1.3/1.4 <sup>5</sup>
All others	Div 1.3	Div 1.2 <sup>3</sup>	Div 1.3 <sup>1</sup>	Div 1.3 <sup>1</sup>

Notes:

<sup>1</sup> Unit risk minimum fragment distance applies, unless excepted on a case-by-case basis by the DDESB.

<sup>2</sup> Fuzed configuration must be tested for propagation.

<sup>3</sup> Unit risk may be justified on a case-by-case basis.

<sup>4</sup> EIDS fuzed means that the fuze has an EIDS booster with an out-of-line non-EIDS explosive and two or more independent safety features.

<sup>5</sup> Hazard class/division 1.4 applies for items packed in nonflammable pallets or packing, stored in earth-covered steel or concrete arch magazines when accepted by USATCES.

## Chapter 8

### Explosives safety Separation Distance (Quantity-Distance)

#### 8-1. Explosives quantity-distance

The severity of damage or injury from an explosion is dependent upon the distance between the potential explosion site and the exposed site; the type of explosives involved (see fig 8-1 for an explanation of types); the quantity of explosives at the potential explosion site; the ability of the potential explosion site to suppress blast overpressure, fragments and debris; and the ability of the surrounding exposed sites to withstand explosion effects. This chapter sets minimum standards for separating a potential explosion site from an exposed site taking these factors into account. These standards represent minimum acceptable levels of protection and for many types of operations do not eliminate injury to personnel or destruction of facilities. Greater levels of protection should be applied where possible to reduce risk. The key to successful and safe explosives operations is to expose the minimum number of persons; for the minimum amount of time; to the minimum amount of ammunition consistent with safe and efficient operations. In all situations, exerted effort should be expended to insure nonessential person are not being exposed to risks associated with ammunition and explosives needlessly.

Hazard Classification/	Division	Definition
1.1		Mass-detonate. Mass-explosion. The principal hazards are blast and fragments.
1.2		Non-mass explosion, fragment producing. HD 1.2 includes items configured for storage and transportation that do not mass detonate when a single item or package in a stack ignites. Explosions cause these items to burn and explode progressively, a few at a time, projecting fragments, firebrands, and unexploded items from the explosion site. Blast effects are limited to the immediate vicinity.
	1.2.1	Those items with a Net Explosive Weight for quantity-distance (NEWQD) > 1.60 pounds (0.73 kg) or that exhibit fragmentation characteristics similar to or greater than (higher density, longer distance). For example: M1 105 mm projectiles regardless of NEWQD.  Small quantities of HD 1.2.1 (< 450 NEWQD), in certain packaging configurations, will react in a manner more typical of an HD 1.1 event.  When located in structures that stop primary fragments, but which generate a secondary debris hazard (e.g., certain earth-covered magazine and hardened structures), the structural damage and debris hazards produced from these events again are more characteristic of an HD 1.1 explosion.
	1.2.2	Those items with an NEWQD < 1.60 pounds (0.73 kg) or that at most exhibit fragmentation characteristics similar to high-explosive 40 mm ammunition regardless of NEWQD.
	1.2.3	AE that does not exhibit any sympathetic detonation response in the stack test, and any reaction more severe than burning in the external fire test, bullet impact test, and slow cook-off test.
1.3		Mass fire, minor blast or fragment, firebrands. HD 1.3 includes items that burn vigorously and cannot usually be extinguished in storage situations. Explosions normally will be confined to pressure ruptures of containers and will not produce propagating shock waves or damaging blast overpressure beyond the magazine distance specified in the tables. Tossing about of burning container materials, propellant, or other flaming debris may cause a severe hazard of spreading fire.
1.4		Moderate fire, no significant blast or fragment. Items present a fire hazard with minimal blast, fragmentation, or toxic hazards.
1.5		Explosive substance, very insensitive (with mass explosion hazard).
1.6		Explosive article, extremely insensitive.
6.1		HD 6.1 includes items that contain only toxic or incapacitating chemical agents.  Items containing both explosives and toxic chemical or riot control agents may be hazard classified as HD 1.1 through HD 1.4, based on testing. The specific hazard division is based on testing in accordance with TB 700-2.  Hazard zones for toxic chemical agents are determined by the relative toxicity of the agents, the amount released to the atmosphere and the rate at which they are released (that is, evaporation, pressure, or explosives dispersal), terrain features, and meteorological conditions. Hazard zone calculations are based on maximum credible events (MCEs), using DDESB Technical Paper No. 10, June 1980.  When siting AE containing toxic chemical agents, both the explosives and toxic chemical agent hazards will be evaluated with the greatest QD governing the siting.

Figure 8-1. Classification of ammunition and explosives

## 8-2. Quantity-distance exceptions

The following exceptions are permitted for reasons of operational necessity:

- a. Limited quantities of HD 1.2.2 items, not to exceed 50 pounds NEW, may be stored in facilities such as hangars, troop buildings, and manufacturing or operating buildings without regard to quantity or distance. Fragmentation shielding will be provided. The items will be stored in their original DOT approved packaging.
- b. Limited quantities of HD 1.3 items, not to exceed 100 pounds NEW, may be stored in facilities such as hangars, troop buildings, and manufacturing or operating buildings without regard to quantity or distance. The items will be stored in their original DOT approved packaging.
- c. Compliance with QD and compatibility criteria is not required for mission essential or operationally necessary

quantities of ammunition and explosives in hazard class and division (HD) 1.4 or 6.1 (excluding toxic chemical munitions).

d. For document destroyers of HD 1.3, quantities in excess of 100 pounds may be positioned for use without complying with QD and compatibility if their Command finds this necessary for security reasons.

### **8-3. Arms room storage**

Compliance with QD and compatibility criteria is not required for mission essential or operational required quantities of ammunition and explosives in HD 1.4 or 6.1 (excluding toxic chemical munitions) stored in arms rooms.

a. Storage of HD 1.4 ammunition is preferred in ammunition holding area or ammunition supply point unless such use would adversely impact operations or result in an unnecessary commitment of resources (for example, require unit personnel, to provide 24-hour security or extended travel).

b. Up to 100 pounds NEW HD 1.3 and up to 50 pounds NEW HD 1.2.2 may be stored.

c. When HD 1.2.2 is stored inside or at less than IBD from inhabited buildings such as barracks or office buildings, fragment barriers will be provided. Minimum acceptable fragment barriers are: 1/4 inch of mild steel plate, or one layer of sand bags, or 12 inches of loose sand or dirt, or equivalent protection.

d. Storage of ceremonial ammunition is not considered an operational necessity. However, a limited quantity of HD 1.3 and HD 1.4 ceremonial ammunition (such as, 75 mm blank, 105 mm blank) may be stored in an arms room provided no other practical alternative exists. The amount of HD 1.3 and HD 1.4 ceremonial ammunition stored will not exceed 100 pounds NEW and will be considered during calculation of HD 1.3 quantities in paragraph 8-3b, above.

e. Prior to a unit storing ammunition in an arms room, the garrison or installation commander will approve the risk assessment that justifies the storage based on operational necessity and safety considerations. In approving this assessment, the commander will consider the need to expose personnel to the proposed amount of explosives for the length of time proposed. The risk assessment will be coordinated with garrison or installation safety, logistics, security, fire protection, and ammunition surveillance personnel. The risk assessment will be posted in the arms room and all arms room personnel will be briefed, at least annually, on its contents. The unit commander, or equivalent-level individual, will ensure that:

(1) Munitions are stored in their original container with original packaging (otherwise an explosives safety site plan is required) because containerization and packing are considerations in determining a munitions HD. However, arms rooms that support guard forces or military police may have one outer pack of each caliber of small arms ammunition open for use.

(2) Storage will be consistent with the safety requirements of this pamphlet and the security requirements of AR 190-11. The use of metal storage containers or cabinets is required and ammunition must be stored under the same criteria as it would in an approved ammunition storage facility, (for example, no combustibles, solvents, petroleum products, or radioactive items in the vicinity of the ammunition).

(3) The appropriate fire and/or chemical hazard symbols are properly posted on the door to the storage area. Appropriate symbols need not be posted on the exterior of the building if only storing HD 1.4 ammunition.

(4) Property book, hand receipt, accountability and inventory procedures will be consistent with 710-series regulations and pamphlets.

f. When storage in an ammunition holding area or ammunition supply point would adversely impact operations or result in an unnecessary commitment of resources (for example, require unit personnel to provide 24-hour security or extended travel) and storage in an arms room is necessary, the acceptable duration of storage will be determined by (garrison) Commander based on a documented risk assessment considering the risks of storage versus the risks of transportation against training mission requirements. Training ammunition will be separated spatially from operational ammunition and listed separately on the arms room inventory.

g. Munitions are stored in accordance with storage compatibility requirements.

h. Quantities in excess of the above must comply with all QD requirements of this chapter, including submission of a site plan.

### **8-4. Structural response to blast**

a. *Conventional structures.* Conventional structures are designed to withstand roof snow loads of 30 pounds per square foot (1.44 kilopascals) and wind loads of 100 miles per hour (161 kilometers per hour). The loads equate to 0.2 pounds per square inch (psi).

(1) Air-blast overpressure at Hazard Division 1.1 barricaded intraline distance (IL(B)) is 12 psi (82.7 kPa); at unbarricaded intraline distance (IL(U)) is 3.5 psi (24 kPa); and at inhabited building distance is 0.9 to HD 1.2 psi (6.2 to 8.3 kPa).

(2) Comparing these loads with the design capacity, it is evident that conventional buildings will be damaged even at inhabited building distance.

(3) Conventional structures, which include aboveground storage facilities, contribute little to propagation protection from either blast or fragments. Propagation protection is provided by distance and/or barricading. The amount of damage to be expected at various pressure levels is described in table 8-1.

**Table 8–1  
Safe separation distances and expected severities (HD 1.1)**

Distance	Over- pressure (psi)	Expected effects	Severity
<b>Inhabited building distance</b>	<b>1.2 - 0.90</b>	—Unstrengthened buildings are likely to sustain damage up to about 5 percent of the replacement cost.	<b>Moderate</b>
<b>W&lt;100,000 lbs</b>	<b>1.2</b>	— Personnel are provided a high degree of protection from death or serious injury, with likely injuries principally being caused by broken glass and building debris.	
<b>W&gt;250,000 lbs</b>	<b>0.9</b>	<p>— Personnel in the open are not expected to be injured seriously directly by the blast. Some personnel injuries may be caused by fragments and debris, depending largely upon the potential explosion site structure and the amount of ammunition and its fragmentation characteristics.</p> <p>Air blast effects on personnel.</p> <p>The following describes air blast over-pressure effects to personnel.</p> <p>One percent eardrum rupture at 3.4 psi exposure.</p> <p>Fifty percent eardrum rupture at 16 psi exposure.</p> <p>Threshold lung rupture at 10 psi (50 msec duration) or 20–30 psi (3 msec duration).</p> <p>One percent mortality at 27 psi exposure (50 msec duration) or 60–70 psi (3 msec duration).</p>	
<b>Public Traffic W&lt;100,000 lbs</b>	<b>2.3 - 1.7</b>	— Unstrengthened buildings are likely to sustain damage approximating 20 percent of the replacement cost.	<b>Critical</b>
<b>W&gt;250,000 lbs</b>	<b>2.3</b>	— Occupants of exposed structures may suffer temporary hearing loss or injury from secondary blast effects such as building debris and the tertiary effect of displacement.	
<b>Route distance</b>	<b>1.7</b>	<p>— Personnel in the open are not expected to be killed or seriously injured directly by blast. There may be some personnel injuries caused by fragments and debris, depending largely upon the potential explosion site structure and the amount of ammunition and its fragmentation characteristics.</p> <p>— Vehicles on the road should suffer little damage unless hit by a fragment or unless the blast wave causes momentary loss of control.</p> <p>— Aircraft should suffer some damage to appendages and sheet metal skin from blast and possible fragment penetration; however, the aircraft should be operational with minor repair.</p> <p>— Cargo ships should suffer minor damage to deck structure and exposed electronic gear from blast and possible fragment penetration, but such damage should be readily repairable.</p>	
<b>Unbarricaded intraline distance (IL(U))</b>	<b>3.5</b>	<p>— Direct propagation of explosion is not likely.</p> <p>— Delayed communication of an explosion may occur from fires or equipment failure at the exposed site.</p> <p>— Damage to unstrengthened buildings will be serious and approximate 50 percent or more of the total replacement cost.</p> <p>— There is a 1 percent chance of eardrum damage to personnel.</p> <p>— Serious personnel injuries are likely from fragments, debris, firebrands, or other objects.</p> <p>— Cargo ships would suffer damage to decks and superstructure from being struck by fragments and having doors and bulkheads on the weather deck buckled by overpressure.</p> <p>— Aircraft can be expected to suffer considerable structural damage from blast. Fragments and debris are likely to cause severe damage to aircraft at distances calculated from the formula <math>18W^{1/3}</math> when NEWs under 9,000 pounds are involved.</p> <p>— Transport vehicles will incur extensive, but not severe, body and glass damage consisting mainly of dishing of body panels and cracks in shatter-resistant window glass.</p>	<b>Critical</b>



**Table 8-1  
Safe separation distances and expected severities (HD 1.1)—Continued**

Distance	Over- pressure (psi)	Expected effects	Severity
<b>Aboveground magazine distance - unbarricaded</b>	<b>8</b>	<ul style="list-style-type: none"> <li>— Damage to unstrengthened buildings will approach total destruction.</li> <li>— Personnel are likely to be injured seriously by the blast, fragments, debris, and translation.</li> <li>— There is a 20 percent risk of eardrum rupture.</li> <li>— Explosives vessels are likely to be damaged extensively and delayed propagation of explosion may occur.</li> <li>— Aircraft will be damaged heavily by blast and fragments; ensuing fire will likely destroy them.</li> <li>— Transport vehicles will sustain severe body damage, minor engine damage, and total glass breakage.</li> </ul>	<b>Catastrophic</b>
<b>Barricaded intraline distance (IL(B))</b>	<b>12</b>	<ul style="list-style-type: none"> <li>— Unstrengthened buildings will suffer severe structural damage approaching total destruction.</li> <li>— Severe injuries or death to occupants of the exposed site may be expected from direct blast, building collapse, or translation.</li> <li>— Aircraft will be damaged beyond economical repair both by blast and fragments. If the aircraft are loaded with explosives, delayed explosions are likely from subsequent fires.</li> <li>— Transport vehicles will be damaged heavily, probably to the extent of total loss.</li> <li>— Immediate spread of the fire between two explosives locations is unlikely when barricades are interposed between them to intercept high-velocity low-angle fragments. Delayed propagation is possible from lobbed munitions and burning materials.</li> <li>— Improperly designed barricades or structures may increase the hazard from flying debris, or may collapse increasing the risk to personnel and equipment.</li> <li>— Control at IL(B). Barricading is required. Exposed structures containing equipment of high monetary value or critical mission importance or where personnel exposure is significant may require hardening to protect personnel and equipment.</li> </ul>	<b>Catastrophic</b>
<b>Aboveground magazine distance barricaded</b>	<b>27</b>	<ul style="list-style-type: none"> <li>— Unstrengthened buildings will be destroyed completely.</li> <li>— Personnel will be killed by direct action of blast, by being struck by building debris, or by impact against hard surfaces.</li> <li>— Transport vehicles will be overturned and crushed by blast.</li> <li>— Explosives vessels will be damaged severely, with propagation of explosion likely.</li> <li>— Aircraft will be destroyed by blast, thermal, and debris effects.</li> </ul>	<b>Catastrophic</b>

*b. Earth-covered magazines.* The earth-covered magazines identified in DDESB TP 15, separated one from another by the minimum distances required in tables 8-11 and 8-12, provide virtually complete protection against propagation of explosion by blast, fragments, and fire; however, there may be some cracking of concrete barrels and rear walls, possible severe cracking and some spalling of front walls, and some damage to doors and ventilators.

*c. Underground facilities.* Underground facilities sited and constructed as specified in chapter 11 provide a high degree of protection against propagation of explosion between chambers by blast, fragments or spall, and between underground and aboveground structures. Delayed propagation between chambers by fire is possible, but this possibility may be minimized by installation of a fire suppression system.

*d. Barricaded open storage modules.* Barricaded open storage modules provide a high degree of protection against propagation of explosion by blast and fragments. However, if flammable materials are present in nearby cells, subsequent propagation of explosion by fire is possible.

(1) When items are separated by  $K=1.1$  distances from a donor explosion, the items will be covered with earth thrown by nearby explosion and unavailable for use until extensive uncovering operations and possibly maintenance are completed.

(2) When items are separated by  $K=2.5$  distances from the potential explosion site, the items should be readily accessible.

(3) As depicted in figure 8-1, a module is a barricaded area comprised of a series of connected cells with hard surface storage pads separated from each other by barricades. A light metal shed or other lightweight fire-retardant cover may be used to protect individual cells from weather. Heavy structures (reinforced concrete, dense masonry units) or flammable material will not be used.

(4) Module storage (open storage) may be used as determined necessary by the Army. However, from the standpoint of explosives safety as well as reliability, covered storage (earth-covered magazines) is preferred for items requiring

protection from the elements. Module storage is considered a temporary expedient and may not be employed in place of standard methods for long-term storage.

(5) The maximum NEW permitted to be stored within each cell is 250,000 pounds (113,636 kg) (total of the explosives fill of all HD 1.1 and/or HD 1.2 ammunition).

(6) Authorized storage will be:

(a) Limited to HE bombs (fuzed or un-fuzed, with or without fins), similarly cased HD 1.1 ammunition, and the following contained in nonflammable or metal shipping containers: 30 mm and smaller ammunition, cluster bomb units, inert munitions components, and hazard division 1.4 munitions.

(b) Stocks in each module normally will be limited to one type of item in the standard shipping configuration unless the controlling authority permits mixed storage.

(c) Module storage of ammunition in flammable outer-pack configurations will be minimized. Combustible dunnage or other flammable materiel shall not be stored in or within 100 feet of modules.

(7) When fire retardant tarpaulins are used as a cover, there must be a minimum of 18 inches between the tarpaulins and the stored ammunition.

(8) Siting criteria—Distance between the nearest edges of stacks of munitions in adjacent cells and modules will be as shown for appropriate explosives weights in table 8–13.

(a) When cell explosives loadings are established for weights other than those shown, minimum distances between stacks will be determined by the formula  $D=1.1W^{1/3}$ .

(b) The distance between a module and other magazines will be determined by applying the IMDs specified in tables 8–11 and 8–12.

(c) The distances between the explosives in the cells of a module, and all other targets will be determined between the nearest edge of the munitions stack in the controlling cell and the nearest point of the exposed site. Notes:

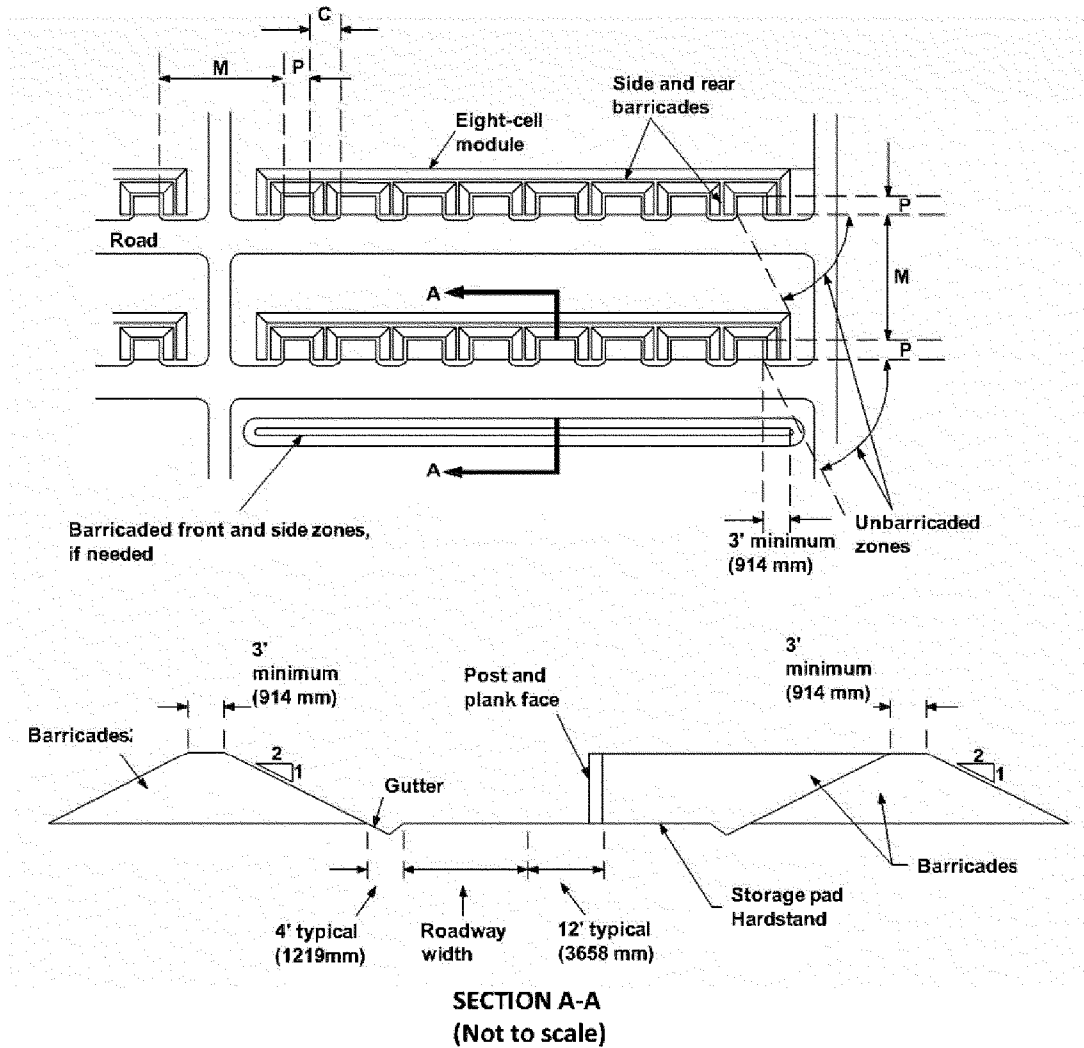

Notes:

<sup>1</sup> Number of cells, cells' NEWQD, pad sizes (P), distances between cells (C) and modules (M), and minimum barricade heights can vary (see table 8-13).

<sup>2</sup> Refer to DODM 6055.09-M, section C5.3, for barricade design criteria and for alternate barricade designs.

<sup>3</sup> Roadway width determined by the DOD Components.

**Figure 8-2. Typical Eight-Cell Open Storage Module**

*e. High performance magazines.* The high performance magazine (HPM) identified in appendix G, with the minimum IMD required by table 8-11, provides virtually complete protection against propagation of explosion by blast, fragments, and fire.

(1) The second story transfer area is enclosed by a pre-engineered metal building which may be severely damaged by an explosion at a nearby potential explosion site.

(2) The amount of damage to be expected at various pressure levels is described in table 8-2.

(3) Unless special design requirements are imposed, access to ammunition items at less than K30 from a donor explosion may require extensive cleanup and a mobile crane to assist in recovery and cleanup.

(4) For the HPM the NEW, for determining separation distances, is based on the MCE. The MCE is determined by

adding the NEW in an individual cell to the NEW at the loading dock. Safe separation distances are calculated using the MCE of the HPM. The MCE for the HPM shall not exceed 60,000 pounds.

### 8-5. Substantial dividing walls

Substantial dividing walls are designed to prevent bay-to-bay simultaneous detonation of HD 1.1 materials. Construction of new substantial dividing walls shall conform to requirements in TM 5-1300. See paragraph 16-28 for guidance pertaining to substantial dividing walls.

### 8-6. Calculation of explosives quantity

The total quantity of explosives in a facility is calculated as shown below. Where the DDESB has approved HE equivalence for a propellant and/or pyrotechnic, then this HE equivalence may be used for determining NEW. In such cases, the sum of the HE plus the HE equivalence of the propellant and/or pyrotechnic will be the applicable NEW. The Joint Hazard Classification System (JHCS) provides explosive weights for all DOD Hazard Classified ammunition and explosives.

a. *Mass-explosion (HD 1.1)*. The NEW is the total weight of all HE plus the total weight of all propellant in the HD 1.1 items.

b. *Non-mass explosion, fragment-producing (HD 1.2)*.

(1) *HD 1.2.1*. The NEW is the total weight of all HE plus the total weight of propellant in all HD 1.2.1 items. In certain situations, the MCE, as outlined in paragraph 8-4e(4) will be used as the basis for determining applicable QD.

(2) *HD 1.2.2*. The NEW is the total weight of all HE plus the total weight of propellant in all HD 1.2.2 items.

(3) *HD 1.2.3 (Unit Risk HD 1.2)*. The NEW is the total weight of all HE plus the total weight of propellant in all HD 1.2.3 items. This material is treated as HD 1.3, however, a minimum IBD will apply, as outlined in paragraph 8-20g(2)(e).

c. *Mass fire, minor blast, or fragment (HD 1.3)*. The NEW is the total weight of all HE, propellant, and pyrotechnics in all HD 1.3 items.

d. *Moderate fire, no blast, or fragment (HD 1.4)*. The NEW is the total weight of all HD, propellant, and pyrotechnics in all HD 1.4 items.

e. *Explosive substance, very insensitive (with mass explosion hazard) (HD 1.5)*. The NEW is the total weight of all HE plus the total weight of propellant in all HD 1.5 items.

f. *Explosive article, extremely insensitive (HD 1.6)*. The NEW is the total weight of EIDS in all HD 1.6 items. However, the weight of EIDS in a single HD 1.6 will also be considered, as specified in table 8-26, for determining quantity.

g. *Exclusions*. Munitions' fillers that do not contribute to explosive effects (for example, colored and HC smoke, dyes, irritants, white phosphorus (WP), plasticized white phosphorus (PWP), and pyrophoric agent TPA) are excluded when determining NEW.

h. *Buffer material/configurations*. If DDESB-approved buffer configurations are provided, the NEW is the explosives weight of the largest stack plus, if applicable, the explosives weight of the buffer material, excluding the NEW of HD 1.4.

### 8-7. Net explosive weight for mixed hazard class/division

In determining the NEW for mixed hazard divisions of ammunition and explosives use table 8-3.

**Table 8-2**  
Mixing of hazard divisions for quantity-distance computations

	1.1	1.2	1.3	1.4	1.6.	1.1 & HD 1.2	1.1 & HD 1.3	1.2 & HD 1.3
1.1	-	A	B	G	C	A	B	D
1.2	A	-	E	G	C	A	D	E
1.3	B	E	-	G	F	D	B	E

**Table 8-2**  
**Mixing of hazard divisions for quantity-distance computations—Continued**

1.6	H	H	H	G	-	H	H	H
-----	---	---	---	---	---	---	---	---

Legend for Table 8-2:

For A:

- (1) Treat the entire quantity of NEW/NEQ [NEQ indicates the quantity is expressed in metric units] as 1.1 and figure the QD.
- (2) Treat the entire quantity of NEW/NEQ as HD 1.2 and figure the QD.
- (3) Use the greater distance.

For B:

- (1) Treat the entire quantity of NEW/NEQ as 1.1 and figure the QD.
- Treat the entire quantity of NEW/NEQ as HD 1.3 and figure the QD.
- (3) Use the greater distance.

For C:

Treat the entire quantity as 1.1.

For D:

- (1) Treats the entire quantity of NEW/NEQ as 1.1 and figure the QD.
- (2) Treat the entire quantity of NEW/NEQ as HD 1.2 and figure the QD.
- (3) Treat the entire quantity of NEW/NEQ as HD 1.3 and figure the QD.
- (4) Disregard the HD 1.4 NEW/NEQ.
- (5) Use the greater distance.

For E:

- (1) Figure the QD for the HD 1.2 NEW/NEQ.
- (2) Figure the QD for the HD 1.3 NEW/NEQ.
- (3) Disregard the HD 1.4 NEW/NEQ.
- (4) Use the greater distance.

For F:

Treat the entire NEW/NEQ as HD 1.3.

For G:

- (1) Calculate QD for type and quantity of HD.
- (2) Disregard the HD 1.4 NEW/NEQ.

For H:

Calculate QD for type and quantity of HD in column heading above.

### 8-8. Calculating quantity distance for two or more potential explosion sites

When several PESs are located near each other, the relationship between the PESs must be considered in order to arrive at either the appropriate quantities of explosives or appropriate safe separation distances that should be maintained for each. The simplest relationship is where all PESs are equal distance from each other, since the quantities permitted in each will be identical for the same HD. The inverse is also simple, when all quantities of explosives are the same; the same quantity-distance separation is required. Therefore the proper QD can be determined using the appropriate QD tables in this chapter.

*a.* When quantities of explosives stored at PESs vary or distances between PESs are different, the determination of QD becomes more complex. To determine the appropriate QD, the relationship between all the PESs must be examined. This is accomplished by considering each potential explosion site as both a potential explosion site and an exposed site.

(1) First each location is considered as a potential explosion site and the other PESs are considered as exposed sites. Using the appropriate QD tables, either the permitted quantity or required safe separation distance is determined between the first potential explosion site and all other PESs as exposed sites. Normally, the distances are fixed therefore the quantity of explosives is varied to meet QD requirements.

(2) The process is repeated for each potential explosion site in turn by once more considering it as the potential explosion site and the other PESs as exposed sites.

(3) Once all the quantities or distances for each potential explosion site have been determined, the permissible QD is then either the least amount of explosives or the greatest distance required by anyone of the combinations. See figure 8-2 for an example.

*b.* One exception is for service magazines that are part of operating lines. The distances are based on the quantity and type of ammunition and explosives in the service magazine or magazines, not the operating line. This protects the operating line from an explosion at the service magazine, while the inverse is not provided for.

## Example of Multiple PES

(Set separation distances)

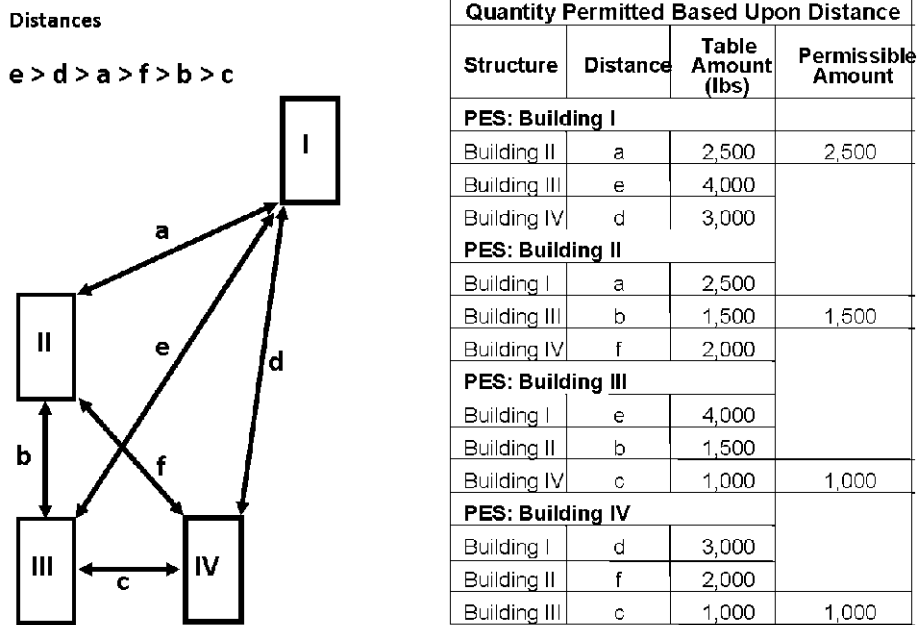

Figure 8–3. Example of Multiple Potential Explosion Sites

### 8–9. Quantity distance relationships of DOD components

The following QD relationships will apply to the separation of facilities of two services, neither of which is a tenant of the other:

- Explosives storage facilities of the Army will be separated from explosives storage facilities of another military service, as a minimum, by appropriate IMD.
- IBD will be provided from explosives storage or operating locations of the Army to explosives operating locations of another service. When operations in each facility present a similar degree of hazard or for Joint or support operations, this separation may be reduced to the appropriate ILD.
- IBD will be provided from explosives storage and operating locations of the Army to explosives tactical facilities of another service. For Joint or support operations, use the appropriate separation distance as though both facilities belonged to a single military service.

### 8–10. Criteria for Non-DOD Explosives Activities (AE Operations and Storage) on U.S. Army Garrisons or installations

- Non-DOD explosives activities shall only be conducted on U.S. Army property per table 8–4. These non-DOD explosives activities must also comply with Bureau of Alcohol, Tobacco, and Firearms, Federal Aviation Administration, and other Federal, state, and local regulations.
- For these types of non-DOD explosives activities, the U.S. Army shall be responsible for ensuring that IMD requirements only, as outlined in explosives site plan submissions, are met. U.S. Army oversight of these non-DOD explosives activities is not intended.
- Non-DOD, explosives activities shall be evaluated based on IMD between multiple PESs to ensure non-propagation. Where IMD is not met, then the NEW at each site not meeting IMD separation requirements shall be added together to determine the basis for the applicable IMD or IBD to use for separation of U.S. Army sites.
- In table 8–4, “Check for IMD” means if IMD is not maintained between each potential explosion site, explosives quantities shall be totaled.
- IBD shall be determined based on this Standard.

- f. The DOD site approval for non-DOD, explosives activities is limited to the area encumbered by the IBD arcs.
- g. Review of building design, lightning protection, and so forth, is not necessary unless design features are used as justification to reduce the IBD arc.

**Table 8-3**  
**Criteria for Non-DOD explosives activities on U.S. Army garrisons or installations**

	To	Non-DOD Storage	DOD/Joint Storage	Non-DOD Operations	DOD Operations	Shared Launch Facilities	Non-related DOD Non-Explosives Facilities/ Operations
<b>From</b>							
<b>Non-DOD Storage</b>		Check for IMD	IMD	Check for IMD	IBD	IBD	IBD
<b>Non-DOD Operations</b>		Check for IMD	IBD	Check for IMD	IBD	IBD	IBD
<b>Shared Launch Facilities</b>		IBD	IBD	IBD	IBD	ILD	IBD
<b>DOD/Joint Storage</b>		ILD	ILD	IBD	ILD	IBD	IBD
<b>DOD Operations</b>		IBD	ILD	IBD	ILD	IBD	IBD

### 8-11. Subdivision of explosives quantities

In some cases, it may be advantageous for QD computations to subdivide a total quantity of mass-detonating explosives into smaller units.

a. Simultaneous detonation will be prevented either by constructing a suitable barrier to provide “Category Four” protection or by adequately separating stacks. Intervening barriers designed to provide “Category Four” protection (prevents simultaneous detonation) in accordance with the principles contained in TM 5-1300 will satisfy this requirement. If this requirement is met, the NEW of the subdivision requiring the greatest distance will govern.

b. If the above requirement is not met, QD computations must be based upon the summation of the mass-detonating explosives in all of the subdivisions.

### 8-12. Interpolation and extrapolation

Interpolation and extrapolation may be used with several of the tables in this chapter. When allowable, permission will be specified in footnotes for that QD table.

### 8-13. Measuring distance

For determining the separation distances from the structure or room containing explosives to various types of exposed sites, measure in accordance with the guidelines in table 8-5.

**Table 8-4**  
**Measuring distance from exposed site**

Measure from Type of exposed site <sup>2</sup>	Distance measured to/from <sup>1</sup>	Comments
Structure not subdivided	Treat as complete structure	To prevent mass detonation between compartments
Structure Subdivided	From outside nearest wall to the compartment containing the greatest explosive hazard	To prevent mass detonation between compartments
Open Storage (such as, modules, and revetments)	From stack face to stack face	
Explosives Outdoors/Vehicle Parked in the Open	To explosive	
Protective Shelters	External wall of the shelter or stall containing the explosive or explosive-loaded vehicle	Measure from center of large missiles, launchers, or pads

**Table 8-4**  
**Measuring distance from exposed site—Continued**

Exposed Site	To nearest point of non-explosives area, location, building, vehicle, aircraft, or taxiway To centerline of runway To nearest edge of ship's channel To nearest edge of open recreational areas
Golf courses	To nearest edge of the tee or green or to centerline of the fairway

Notes:

<sup>1</sup> Distances are expressed in feet or meters (as applicable) and measured along a straight line. For large intervening topographical features such as hills, measure over or around the feature, whichever provides the shorter distance.

<sup>2</sup> When railroad cars or motor vehicles containing ammunition and explosives are not separated from operating buildings, magazines, or open storage sites containing ammunition and explosives so as to prevent their mass-detonation, the total quantity of explosives will be considered as a unit. The separation distance will be measured from the nearest outside wall of the building, railcar, vehicle, or edge of open stack, as appropriate, to an exposed site. If the explosives are separated into smaller units so that propagation of the explosion between the explosives in the railcars, motor vehicles, or other units will not occur, the separation distance will be measured from the nearest controlling explosives unit, railcar, or vehicle to a target.

**8-14. Ammunition and explosives risk**

The major risks associated with ammunition and explosives involve the hazards of fragments and blast. The inherent purpose of ammunition and explosives is to destroy structures and personnel, thus, accidental activation or activation without appropriate protective measures can result in severe consequences. Therefore, when determining safe separation distances for separating PESs from other structures, facilities, activities and operations, both the effects of the blast and fragments must be considered. Then based on the greatest risk, the appropriate distance is provided. Fortunately, today's ammunition and explosives, except for bulk items, normally contain several safety devices to reduce the probability of accidental activation. Since the prediction of precise parameters relating to explosions is not an exact science due to the magnitude of factors involved - everything from the explosives themselves, their storage configuration, the structure, the terrain, the weather- it is impossible to exactly predict the explosion's behavior or its results.

**8-15. Blast considerations**

*a. Risk.* An essential part of analyzing the risk associated with ammunition and explosives is the hazards associated with the blast wave. For blast protection from HD 1.1 materials, required distances listed in this standard which have been calculated using formulas of the type  $D=KW^{1/3}$  where D is the distance in feet, K is a factor depending upon the risk assumed or permitted, and W is the NEW in pounds.

(1) When metric units are used in the formula  $D=KQ^{1/3}$ , the symbol Q denotes net explosive quantity (NEQ) in kilograms and the distance D is expressed in meters (m).

(2) The value of K in English units is approximately 2.5 times its value in metric units. For example, if  $D(m)=6Q^{1/3}$ , then  $D(feet)=15W^{1/3}$ . Distance requirements determined by the formula with English units are sometimes expressed by the value of K, using the terminology "K9," "K11," "K18," to mean K=9, K=11, and K=18.

(3) Inhabited building distance. The minimum distance required between the potential explosion site and any structure, except explosive-related operations buildings and activities, where persons live, work or assemble. Inhabited building distances apply to all areas beginning at the installation boundary. Even at this distance, conventional structures may not provide complete protection from blast. The greatest hazard may be broken glass since the weakest portions of any conventional structure are the windows.

(4) The inhabited building distance (in feet) is  $40W^{1/3}$  for quantities of up to 250,000 pounds and then the formula  $50W^{1/3}$  is used. This equates to 1.2 - 0.90 psi incident overpressure. Table 8-8 provides calculated distances for various NEWs up to 500,000 pounds.

(5) Broken glass and structural damage can be reduced by orientation and by keeping the surface area of exposed glass panels to a minimum or by using blast resistant windows.

*b. PTRD.* The minimum distance separating a potential explosion site from a public highway, navigable waterway, passenger railway or other traffic route used by the public, including roads on a military reservation used routinely by the general public for through traffic. Unless access is clearly limited; for example, by unsuitable terrain or travel not open to the public because it is government-owned; PTRD apply to all roads outside of a government installation boundary. Public traffic route distances also apply to most passenger vehicle parking areas and to open recreational areas that do not include bleacher stands or other places where large numbers of personnel may be present.

(1) The PTRD (feet) is  $24W^{1/3}$  for quantities up to 250,000 pounds and then the formula  $30W^{1/3}$  is used. This equates to 2.3 - 1.7 psi incident overpressure. Table 8-8 provides calculated distances for various NEWs up to 500,000 pounds.

(2) PTRD at  $24W^{1/3}$ . The risk of injury or damage due to fragments from limited quantities of explosives at the potential explosion site can be reduced by barricading. Also, many situations arise when control of pressure due to



monetary value or critical mission importance or where personnel exposure is significant may require hardening to protect personnel and equipment.

(3) PTRD at  $30W^{1/3}$ . The risk of injury or damage due to fragments from limited quantities of explosives at the potential explosion site may be reduced by barricading or applying minimum fragment distance requirements.

*c. Unbarricaded intraline distance (IL(U)).* The minimum distance required between ammunition and explosives-related-operations building and exposed explosives-related-operation buildings or storage sites. It also applies to sites within an ammunition and explosives-related operating line. Unbarricaded distance is used when there is no barricade at the exposed site.

(1) IL(U) is calculated using the formula  $18W^{1/3}$ . This equates to 3.5 psi incident overpressure. Table 8–9 provides calculated intraline distance to exposed sites from PESs which are not earth-covered magazines. Table 8–10 provides calculated intraline distances to the exposed site when the potential explosion site is the earth-covered magazines.

(2) Monetary value or critical mission importance or where personnel exposure is significant may require hardening to protect personnel and equipment.

(3) Many situations arise in which control of pressure by suitably designed suppressive construction at the potential explosion site or protective construction at the exposed site are practical. Using such construction to withstand blast overpressure is encouraged if it is more economical than distance alone, or if sufficient distance is not available to prevent the overpressure from exceeding this level.

*d. Barricaded intraline distance (IL(B)).* The minimum distance required between ammunition and explosives-related-operations building and exposed explosives-related-operations buildings or storage sites when a barricade is present at the exposed site. It also applies to sites within an ammunition and explosives-related operating line.

(1) IL(B) (feet) is calculated using the formula  $9W^{1/3}$ . This equates to 12 psi incident overpressure. Table 8–9 provides calculated intraline distance to exposed sites from PESs which are not earth-covered magazines. Table 8–10 provides calculated intraline distances to the exposed site when the earth-covered magazines is potential explosion site.

(2) Barricaded distance can only be used when there is a barricade at the exposed site and the barricade is orientated between both structures as to protect the exposed site.

(3) Exposed structures containing equipment of high monetary value or critical mission importance or where personnel exposure is significant may require hardening to protect personnel and equipment.

*e. Aboveground magazine distance.* The minimum distance required between an exposed site and all open explosives storage areas, explosives storage vehicles, or aboveground explosives storage structures, which do not meet the requirements of an earth-covered magazine.

(1) Aboveground magazine distance is calculated using the formula  $11W^{1/3}$ . This equates to 8 psi incident overpressure. Table 8–11 and table 8–12 are used in combination to determine proper quantity-distance requirements. Table 8–11 is used to determine the appropriate hazard factor (K factor) based on the intermagazine exposure and then table 8–12 is utilized to determine the required NEW or distance.

(2) Barricades will prevent immediate propagation of explosion, but provide only limited protection against delayed propagation.

*f. Intermagazine distance (IMD).*

(1) Magazines are sited at IMD so that communication of explosion from one magazine to another is unlikely. Again, table 8–11 and table 8–12 are used in combination to determine proper QD. Table 8–11 is used to determine the appropriate hazard factor (k factor) based on the intermagazine exposure and then table 8–12 is utilized to determine the required NEW or distance.

(2) Actual siting requirements are influenced by the construction features of the magazine, the types and quantities of ammunition and explosives they contain and the ES. Table 8–6 provides a matrix of all the appropriate separations for the various combinations of exposed site and potential explosion site.

## **8–16. Magazine requirements and orientation**

*a. Magazine requirements.*

(1) The earth-fill or earth-cover between earth-covered magazines may be either solid or sloped to meet the requirements of other construction features. However, a minimum of two feet of earth must be maintained over the top of each magazine, otherwise the magazine will be considered an aboveground magazine. A minimum slope of 1.5 horizontal to 1 vertical starting directly above the spring line of each arch will be maintained to meet explosives safety requirements. New facilities will have a slope of 2 horizontal to 1 vertical to reduce erosion and ease maintenance operations.

(2) Magazine must comply with its structural design criteria. New construction of earth-covered magazines must meet the requirements of the current revision of the drawings listed in DDESB Technical Paper 15.

(3) An analysis will be done to determine if the magazine being sited is equivalent to the requirements indicated in the drawings in appendix G.

(4) When considering relationships between earth-covered magazines and aboveground magazines or facilities requiring ILD and both contain HD 1.1 ammunition and explosives, the question regarding the use of barricaded or unbarricaded distances arise. The following criteria shall apply:

- (a) The location, height, and length of a barricade shall be determined as follows:
1. The barricade may be placed anywhere between the potential explosion site and the exposed site. The location determines the barricade's required height and length.
  2. Refer to paragraph 16-25b for determination of required barricade height and length.
- (b) Quantities above 500,000 lbs NEW in one storage magazine location are not allowed except for liquid propellants.
- (c) The distance given in table 8-13 for up to 100 lbs NEW constitutes the magazine spacing permitted.
- (d) Requirements specified above apply only to the storage of HD 1.1 ammunition and explosives. Existing 7-bar, 3-bar, or undefined earth-covered magazines, regardless of orientation, (and sited one from another for at least 100 pounds HD 1.1), may be used to their physical capacity for the storage of HD 1.2, 1.3, and HD 1.4, provided distances to other exposures comply with applicable QD requirements.
- b. Orientation.* When a blast wave is reflected from a surface at other than grazing incidence (side-on-orientation), the overpressure may be increased substantially over the free-field value. High reflected pressure and impulse can damage doors and headwalls and propel the debris into the earth-covered magazine so that the explosion is communicated by impact with the explosive contents. Therefore the orientation of magazines plays a part in determining the safe separation distance. Figure 8-3 illustrates various orientations and required types of distances.

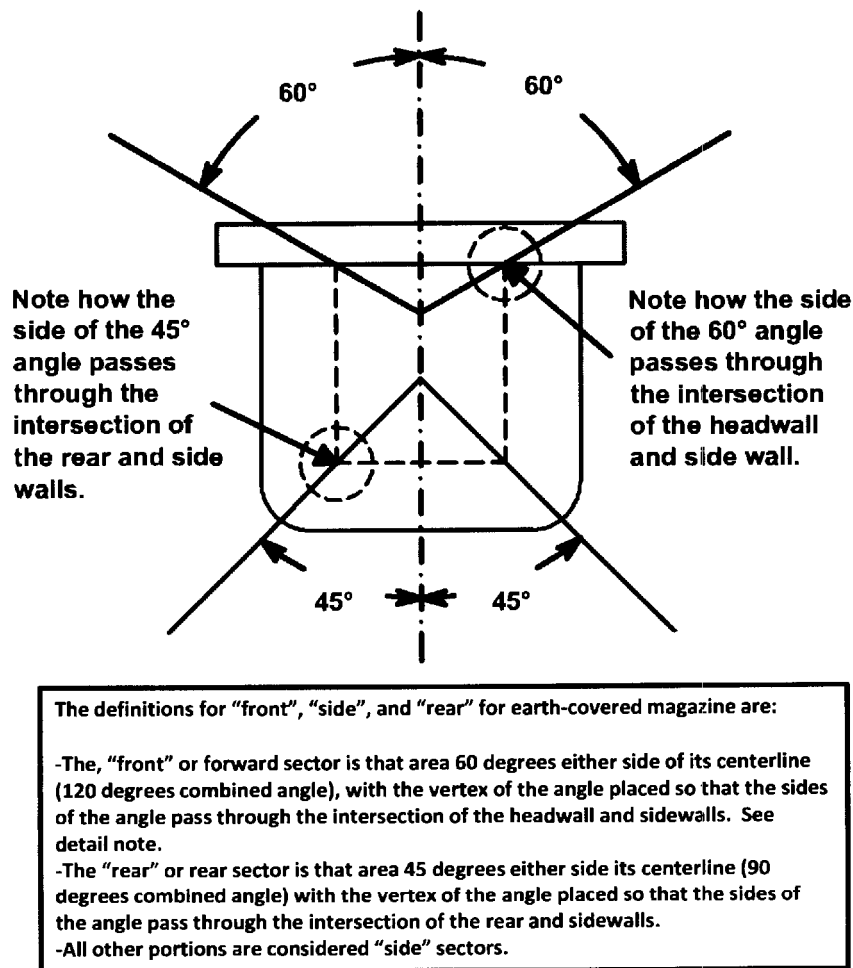
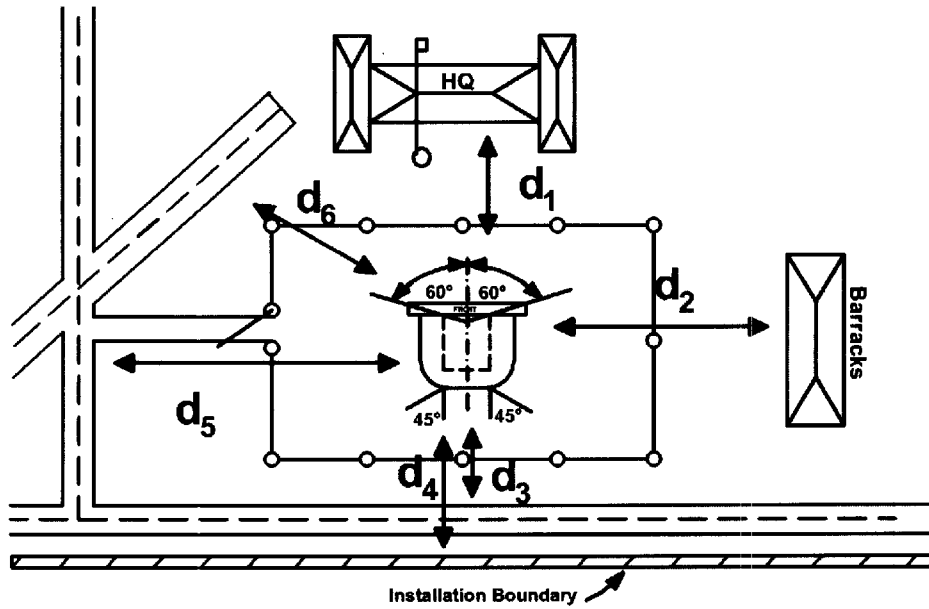
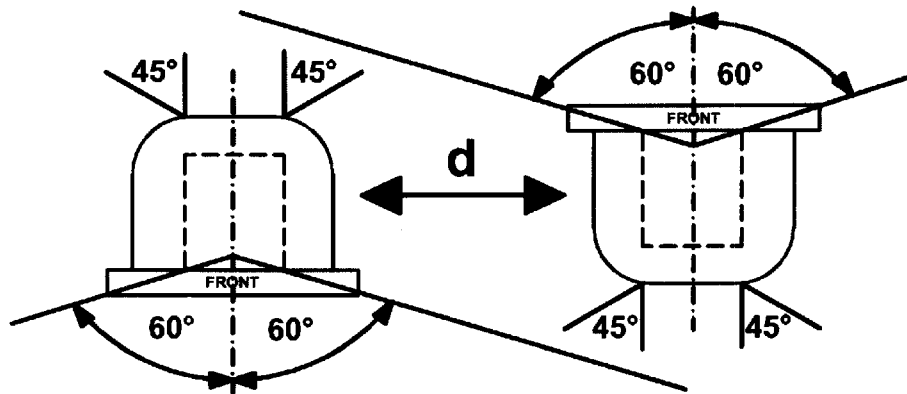

Figure 8-4. Magazine Orientation - Explanation of sectors



- Notes:**
- $d_1$  = IBD front exposure distance to HQ
  - $d_2$  = IBD side distance to barracks
  - $d_3$  = PTRD rear distance to road
  - $d_4$  = IBD rear distance to garrison or installation boundary
  - $d_5$  = PTRD side distance to road
  - $d_6$  = PTRD front distance to road

Figure 8-4. Magazine Orientation - Public traffic rout exposure-Continued



- Note:**
- $d$  = side to side exposure since not within front 120 degree angle or rear 90 degree angle.

Figure 8-4. Magazine Orientation - Alternating side-to-side exposure-Continued

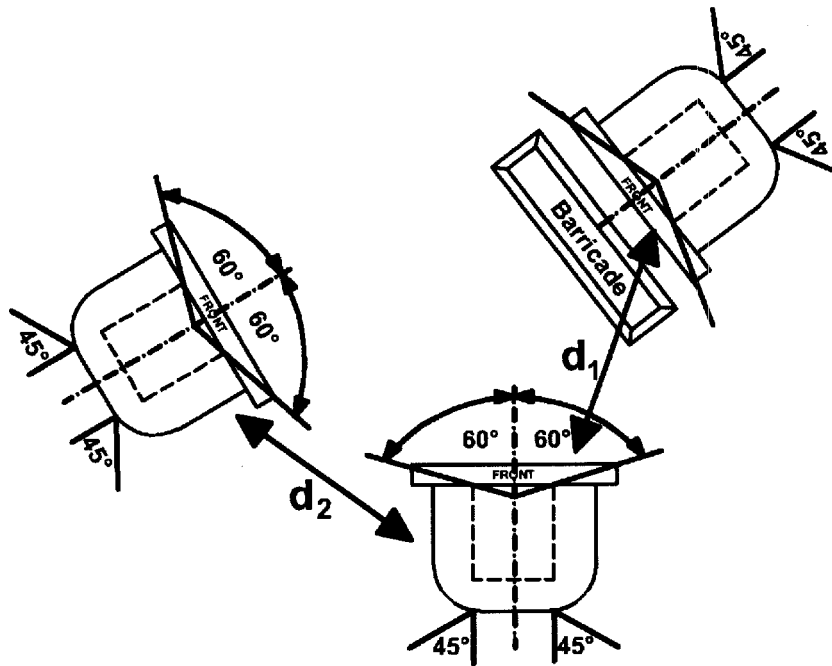

Note:  
d1 = barricaded front-to-front exposure  
d2 = unbarricaded front-to-front exposure

Figure 8-4. Magazine Orientation - Multi-magazine exposure—Continued

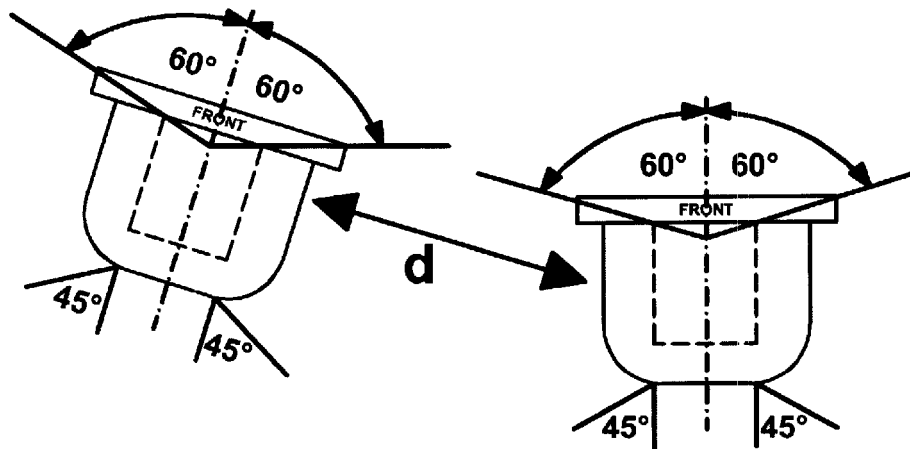

Note:  
d = side-to-side exposure since neither earth-covered magazine is within the 120 degree front of the other.

Figure 8-4. Magazine Orientation - Angle side-to-side exposure—Continued

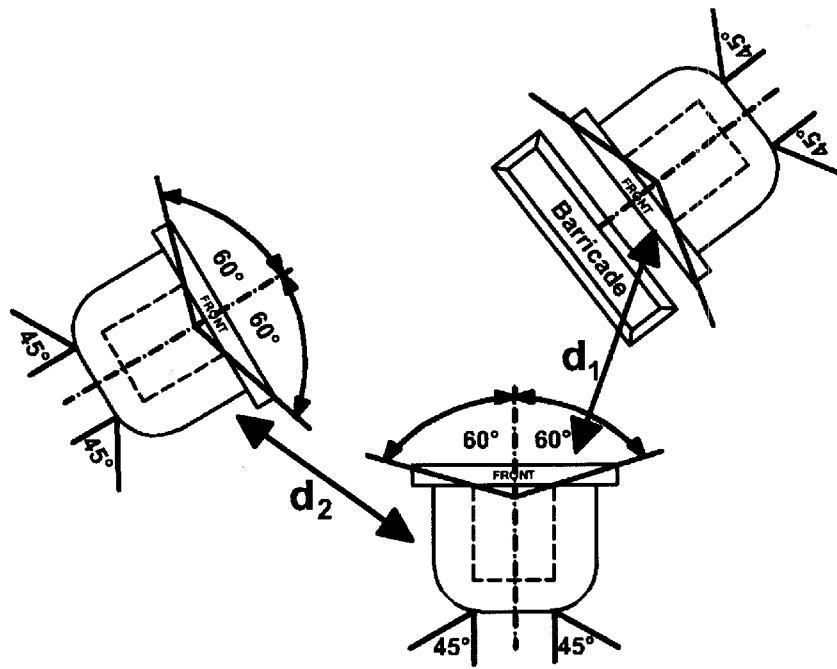

Note:  
 d1 = barricaded front-to-front exposure  
 d2 = unbarricaded front-to-front exposure

Figure 8-4. Magazine Orientation - Front to side exposure—Continued

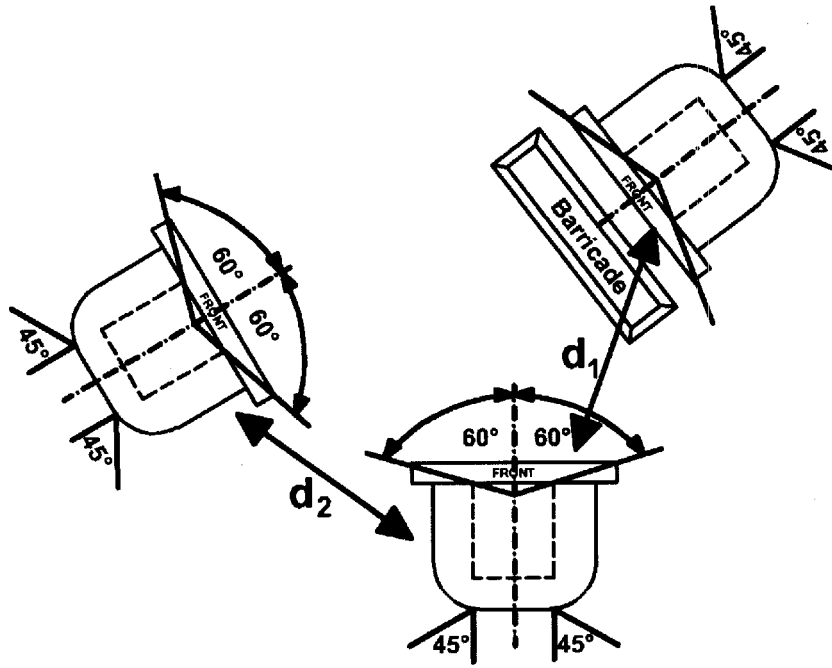

**Note:**  
 $d_1$  = barricaded front-to-front exposure  
 $d_2$  = unbarricaded front-to-front exposure

Figure 8-4. Magazine Orientation - Front-to-front exposure—Continued

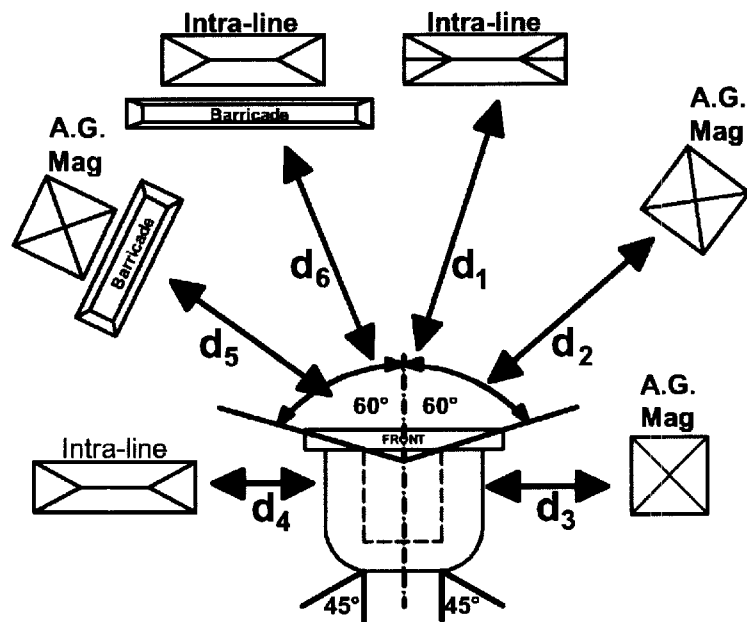

**Note:**  
 $d_1$  = ECM front intra-line distance  
 $d_2$  = ECM front to A.G. Magazine distance  
 $d_3$  = ECM side to A.G. Magazine distance  
 $d_4$  = ECM side intra-line distance  
 $d_5$  = ECM front to barricaded A.G. Magazine distance  
 $d_6$  = ECM front barricaded intra-line distance

Figure 8-4. Magazine Orientation - Multifaceted ECM exposures—Continued

### 8-17. Exposed site

The exposed site is a location which will be damaged by the hazardous effects (for example, blast, fragments, debris, or heat flux) from an explosion at the potential explosion site. The type and use of the location will determine the amount of risk that has been accepted for it by the standards contained in this pamphlet. It is important to understand that by employing these standards, even though based upon actual testing and accident data, they do not guarantee significantly greater damage may not occur. As stated earlier, there are too many variables which may affect the actual results. Table 8-6 provides a list of various types of structures and activities and the type of safe-separation distances required for them. When feasible and mission execution allows, greater separation distances should be used.

**Table 8–5**  
**Type of exposed sites and safe separation distance required**

Type of structure/activity	Safe separation distance required	Notes
Aboveground storage tanks	IBD (table 8–7)	<p>1. The guidance below will be followed to prevent rupture and collapse of unprotected aboveground storage tanks for hazardous materials (such as petroleum, oils, lubricants, industrial chemicals). Exceptions: Large permanent bulk storage facilities are of primary concern when applying IBD to storage tanks. For smaller tanks, it may be best to weigh the cost of distance and protective construction against the strategic value of the stored material, the ease of replacement after an accident, and the potential environmental impact. The command may approve distances less than IBD without formal certificate of risk acceptance through such a risk management process, but only if spill containment is provided to safeguard adjacent facilities.</p> <p>2. Distances less than IBD may be used when an engineered design protects against ruptures and collapse from fragments and blast.</p> <p>3. Small quantities of POL and other hazardous materials used for operational purposes require no specific QD separation distance for explosion safety.</p> <p>4. A service tank supporting a single potential explosion site shall be separated from the potential explosion site by the appropriate NFPA distance (see NFPA, parts 30 and 31). The distance from the service tank to other PESs shall be the NFPA distance or the QD distance between the PESs, whichever is greater. Consider the following example: An explosion operating line consists of two buildings, A and B. For QD purposes, A and B are separated by 200 feet IBD. A service tank supports A. The NFPA requires 25 feet from the tank to A. The distance between the tank and the other potential explosion site (Building B) is the greater of the NFPA distance (25 feet) or the QD distance between A and B (200 feet). Therefore, the distance required between the tank and B is 200 feet.</p> <p>5. QD from underground ammunition storage to above-ground storage tanks must be determined on a site specific basis taking account of crater, blast, ground shock, debris hazards, and potential adverse environmental impacts.</p>
Administrative areas	IBD	
Administrative area parking lots	PTRD	Minimum fragment distances apply.
Bleachers - training and recreational	IBD	Open areas between explosive storage and handling sites and between these sites and nonexplosive buildings and structures shall be controlled carefully regarding use for recreation or training facilities. As a general rule, the fragment hazard will be severe from the explosion site out to approximately the PTRD.
Break rooms	Prudent fire protection distance	
Briefing rooms for daily work schedules or on-site safety matters	Prudent fire protection distance	
Classification yard from other structures	Magazine distance	
Classification yard to other structures	Appropriate safe-separation distance applies to non-explosives locations as well as explosives locations if the yard is used at any time for any purpose other than listed at right	<ol style="list-style-type: none"> <li>1. Receiving, dispatching, classifying, and switching of cars.</li> <li>2. When a classification yard is used solely as an interchange yard, see below.</li> <li>3. Conducting external inspection of motor vehicles and railcars, or opening of free rolling doors of railcars to remove documents and make a visual inspection of the cargo.</li> </ol>
Electrical distribution lines	Distribution lines, the poles or towers supporting them, and electrical substations directly connected to distribution lines will be separated from PESs by PTRD, based on blast only. (Use formulas contained in notes to table 8–8.)	These are normally lines solely supplying multiple garrison or installation locations.



**Table 8-5**  
**Type of exposed sites and safe separation distance required—Continued**

Type of structure/activity	Safe separation distance required	Notes
Electrical service lines serving a combustible facility or an open potential explosion site.	No closer than the distance between the supporting poles or towers.	<ol style="list-style-type: none"> <li>Line must be run underground for the last 50 feet to an explosives facility.</li> <li>Service lines are those lines supplying individual garrison or installation locations.</li> <li>If an effective means is provided to ensure that energized lines, upon breaking, cannot come into contact with the combustible facility or an open potential explosion site or its appurtenances, then they may be closer than the distance between the poles. Examples of effective means include messenger lines, cable trays, and ground fault circuit interrupters. Before implementing any of these means, a safety submission must be approved.</li> </ol>
Electrical transmission lines - 69 kV or more	<p>A. IBD, based on blast — if the line is part of a grid system serving a large off post area use.</p> <p>B. PTRD based on blast only — If loss of the line will not create a serious social or economic hardship use.</p>	<ol style="list-style-type: none"> <li>A minimum distance equal to the length of the lines between the supporting poles or towers, if loss of the line does not cause loss of power (that is, power is rerouted through other existing lines and/or networks). This distance may be further reduced if an effective means is provided to ensure that energized lines, upon breaking, cannot come into contact with facilities of combustible construction or an open potential explosion site.</li> <li>Transmission lines are those lines supplying locations outside the garrison or installation uniquely, or in common with the garrison or installation. Any line carrying 69 kV or more shall be classified as a transmission line for QD purposes.</li> </ol>
Heating plants	Prudent fire protection distance	
Industrial areas	IBD	
Inert storage	Command determined	<ol style="list-style-type: none"> <li>Commands shall determine acceptable locations for inert storage that is directly related to the explosives mission and for inert storage that is not directly related but where control of and access to such inert storage is restricted only to personnel directly related to the explosives mission.</li> <li>Commands shall determine what constitutes "directly related." The following apply to inert storage: <ol style="list-style-type: none"> <li>Locations for inert storage shall be determined only after consideration of personnel exposure, the importance of the materiel in relation to the explosives mission, the operational conditions, and the availability of space.</li> <li>Sites meeting the conditions above do not require site plans.</li> <li>Inert storage that will be accessed by personnel not related to the explosives mission shall be sited as inhabited buildings (based on blast only). Minimum fragment distances do not apply.</li> </ol> </li> </ol>
Inter-service support and tactical facilities	See paragraph 8-9	<ol style="list-style-type: none"> <li>Common requirements.</li> <li>Appropriate safety distances provided herein will be applied between Army facilities and facilities of another military service regardless of the boundary between the Army and other service installations.</li> <li>Safety criteria based on toxicity, noise, thermal radiation, flight trajectory, incendiary, or other hazards may be greater than explosives safety distance criteria. In these cases, the criteria based on the greatest hazard will be considered.</li> </ol>
Joiner (wood/metal) shops	Prudent fire protection distance	
Line offices	Prudent fire protection distance	
Loading docks servicing firing ranges	ILD	<ol style="list-style-type: none"> <li>Separated from firing points having either unarmored vehicles or unprotected personnel by ILD.</li> <li>For firing points with armored vehicles when personnel are in the vehicles with the hatches closed, no QD applies, but a 100 feet fire protection distance must be maintained from the firing point to the loading dock.</li> <li>Separate loading docks will be sited on the basis of use.</li> </ol>
Loading docks servicing magazines	IMD	Separate loading docks will be sited on the basis of use.

**Table 8-5**  
**Type of exposed sites and safe separation distance required—Continued**

Type of structure/activity	Safe separation distance required	Notes
Loading docks serving operating buildings	ILD	Separate loading docks will be sited on the basis of use.
POV Parking Lots for administrative areas	PTRD	Minimum fragment distances apply.
POV Parking Lots serving multiple PESs	ILD	Access for emergency vehicles must be provided.
POV Parking Lots serving a single potential explosion site	ILD	<ol style="list-style-type: none"> <li>1. May be separated at less than ILD only from its associated facility but no less than 100 feet is required to the associated facility to protect it from vehicle fires.</li> <li>2. Access for emergency vehicles must be provided.</li> </ol>
Rail holding yards	Aboveground magazine	Rail holding yards will be laid out on a unit car-group basis with each car-group separated by the applicable aboveground magazine distance. Separate from other facilities by applicable QD criteria.
Rail holding yards -Christmas tree	Aboveground magazine	<ol style="list-style-type: none"> <li>1. Separated by the applicable aboveground magazine distance for the net quantity of HE in the cars on the spurs.</li> <li>2. Will be separated from other facilities by the applicable QD criteria.</li> <li>3. Arrangement consisting of a ladder track with diagonal dead-end spurs projecting from each side at alternate intervals.</li> </ol>
Rail yards two parallel ladder tracks connected by diagonal spurs	Aboveground magazine	<ol style="list-style-type: none"> <li>1. Separated by applicable aboveground magazine distance for the unit-group quantities of HE.</li> <li>2. Will be separated from other facilities by the applicable QD criteria.</li> </ol>
Railcar holding yards	QD separations are not required	May be used to interchange truck trailers or railcars between the commercial carrier and the Army activity and to conduct visual inspections.
Railcar inspection stations	QD separations are not required	<ol style="list-style-type: none"> <li>1. They should be as remote as practical from hazardous or populated areas.</li> <li>2. Activities that may be performed at the inspection station after railcars containing ammunition and explosives are received from the delivering carrier and before further routing within the garrison or installation are as follows: External visual inspection of the railcars.</li> <li>3. Visual inspection of the external condition of the cargo packaging in vehicles (such as, trailers, railcars) that have passed the external inspection indicated above.</li> <li>4. Interchange of railcars or MILVANS between the common carrier and the Army activity.</li> </ol>
Railcar Interchange yards	Applicable QD tables apply unless meets remarks.	<ol style="list-style-type: none"> <li>1. Railcar interchange yards are not subject to QD regulations when they are used exclusively— <ol style="list-style-type: none"> <li>a. For the interchange of railcars containing ammunition and explosives between the commercial carrier and Army activities.</li> <li>b. To conduct external inspection of the railcars, or MILVANS containing ammunition and explosives.</li> <li>c. To conduct visual inspection of the external condition of the cargo in vehicles (such railcars, and MILVANS) that passed the external inspection.</li> </ol> </li> </ol>
Recreational facilities - open air - no structures	Sited at not less than PTRD and preferably as near IBD as practical.	Open areas between explosive storage and handling sites and between these sites and non-explosive buildings and structures shall be controlled carefully regarding use for recreation or training facilities. As a general rule, the fragment hazard will be severe from the explosion site out to approximately the PTRD. For an exception, see table 8-16 and paragraph 8-15b.
Recreational facilities - structures, including bleachers	Sited at not less than IBD.	Open areas between explosive storage and handling sites and between these sites and non-explosive buildings and structures shall be controlled carefully regarding use for recreation or training facilities. As a general rule, the fragment hazard will be severe from the explosion site out to approximately the PTRD. For an exception, see table 8-16 and paragraph 8-15b.

**Table 8-5**  
**Type of exposed sites and safe separation distance required—Continued**

Type of structure/activity	Safe separation distance required	Notes
Roll-on or roll-off operations (not involving lifting)	QD criteria apply to all roll-on or roll-off operations.	<p>Site plans will be submitted in accordance with DA Pam 385-65. When QD requirements cannot be met the following mitigation factors should be considered:</p> <ol style="list-style-type: none"> <li>1. Total NEWQD present shall not exceed 50,000 lbs.</li> <li>2. Conducted on garrisons or installations under U.S. control, when possible, to limit exposures to the public.</li> <li>3. All ammunition and explosives present (such as, in trailers, rail-cars, barges, ships) must be associated only with the RORO operation being conducted.</li> <li>4. Roll-on or roll-off operations shall not exceed 24 hours following arrival of ammunition and explosives, including ammunition and explosives staged at a transshipment point.</li> <li>5. Roll-on or roll-off operations shall be located as remote as practicable from populated areas, in order to minimize exposure of unrelated personnel.</li> <li>6. Off-installation military vans/International Standardization Organization (MILVAN/ISO) container inter- or intra-modal transfers (involving highway and rail modes only) where containers are not stored or other operations performed.</li> </ol>
Secure explosives holding area.	Aboveground magazine	<ol style="list-style-type: none"> <li>1. Will be laid out on a unit truck-group basis with each group separated by the applicable aboveground magazine distances.</li> <li>2. Will be separated from other facilities by the applicable QD criteria.</li> <li>3. An area designated for the temporary parking of commercial carriers' motor vehicles transporting DOD-owned Arms, Ammunition, and Explosives (AAE), classified (SECRET or CONFIDENTIAL) materials, and controlled cryptographic item (CCI). There are two types of secure holding areas. (Note: Although the intent of such areas is to provide a secure storage location for commercial carriers while in-transit, or during emergencies or other circumstances that are beyond a carrier's control, this Standard imposes no requirement for garrisons or installations to have such areas. The term Secure Holding Area is applicable to areas (CONUS, Hawaii, Alaska, and Puerto Rico) governed by Part 205 of Defense Transportation Regulation (DTR) 4500.9-R, Part II Cargo Movement.</li> </ol>
Secure Non-explosives Holding Area	The holding of HD 1.4S materials, without regard to QD, is permitted at this location	No siting required if located outside all QD arcs. If located within a QD arc, provide appropriate safe separation distance.
Security posts and similar locations	Prudent fire protection	May be at explosives operations servicing only one building or operation.
Service tanks - Unprotected	May be sited in accordance with table 8-7 provided the conditions in the notes are met-	<ol style="list-style-type: none"> <li>1. Unprotected service tanks which support aboveground explosives storage or operating complexes, but not inhabited buildings (such as those in administrative, supply, industrial, and housing areas).</li> <li>2. The Command must accept the possible loss of the tanks and any collateral damage that a fire might cause if the tanks were punctured by fragments.</li> <li>3. A dike system must be installed meeting the requirements of NFPA, part 30 to provide spill containment.</li> <li>4. If the tank is supplied by a pipe system as opposed to a tank truck, then the supply pipe must be protected from blast and fragments to prevent a spill larger than the contents of the tank. If the supply pipe is underground, it will be located from PESSs in accordance with below. If it is aboveground, use IBD or protective design in accordance with this pamphlet.</li> </ol>
Storage tanks for water	<p>-QD does not apply if the loss of the water tank is acceptable</p> <p>-IBD applies if the loss of the water tank is unacceptable</p> <p>-Buried tanks and associated components of like value shall meet the siting requirements below for underground tanks</p>	<ol style="list-style-type: none"> <li>1. A key QD consideration is whether loss of the water tank is acceptable. If a water tank is used for firefighting and no adequate alternate water supplies exist, the tank is essential and its loss is unacceptable. If adequate alternate water supplies do exist, loss of the tank may be acceptable. However, consider other factors, such as the replacement cost of the tank and the effect of its loss on the garrison or installation mission, before making a final determination.</li> <li>2. The Command shall designate the approval authority level for the siting of aboveground water tanks within IBD of PESSs, and for buried tanks or pipelines sited at less than the distances required see "Underground pipelines".</li> </ol>

**Table 8-5**  
**Type of exposed sites and safe separation distance required—Continued**

Type of structure/activity	Safe separation distance required	Notes
Training facilities - open air - no structures	Sited at not less than PTRD — preferably as near IBD as practical.	Open areas between explosive storage and handling sites and between these sites and nonexplosive buildings and structures shall be controlled carefully regarding use for recreation or training facilities. As a general rule, the fragment hazard will be severe from the explosion site out to approximately the PTRD. For an exception, table 8-16 and paragraph 8-15b.
Training facilities - structures, including bleachers	IBD	Open areas between explosive storage and handling sites and between these sites and nonexplosive buildings and structures shall be controlled carefully regarding use for recreation or training facilities. As a general rule, the fragment hazard will be severe from the explosion site out to approximately the PTRD. For an exception, see table 8-16 and paragraph 8-15b.
Transportation mode change locations	QD criteria apply to all transfer operations involving ammunition and explosives	Movement and transfer of ammunition and explosives must comply with national, international, and host country-specific transportation regulations with the appropriate safe-separation distance for each exposed site based on its type and use.
Truck holding yards	Aboveground magazine	<ol style="list-style-type: none"> <li>1. Where feasible, trucks will be separated individually or in truck-groups by the applicable aboveground magazine distance.</li> <li>2. Will be separated from other facilities by the applicable QD criteria.</li> </ol>
Truck inspection stations	QD separations are not required but they should be as remote as practical from hazardous or populated areas.	<p>Activities that may be performed at the inspection station for motor vehicles containing ammunition and explosives after they are received from the delivering carrier and before further routing within the garrison or installation are as follows:</p> <ol style="list-style-type: none"> <li>1. External visual inspection of the vehicles.</li> <li>2. Visual inspection of the external condition of the cargo packaging in vehicles (such as trucks, trailers, railcars) that have passed the external inspection indicated above.</li> <li>3. Interchange of trucks, trailers, railcars, or MILVANS between the common carrier and the Army activity.</li> </ol>
Truck-Trailer Interchange yards	Applicable QD tables apply unless meets remarks.	<ol style="list-style-type: none"> <li>1. Truck, interchange yards are not subject to QD regulations when they are used exclusively—</li> <li>2. For the interchange of vehicles containing ammunition and explosives between the commercial carrier and Army activities.</li> <li>3. To conduct external inspection of the trucks, trailers, or MILVAN's containing ammunition and explosives.</li> <li>4. To conduct visual inspection of the external condition of the cargo in vehicles (such as trucks, trailers, and MILVAN's) that passed the external inspection.</li> </ol>
Underground pipelines	<p>-Separation for HD 1.1 use <math>D=3.0W^{1/3}</math> with a minimum distance of 80 feet.</p> <p>-Separated HDs 1.2 through 1.4 by a minimum distance of 80 feet.</p>	
Underground tanks	<p>-Separation for HD 1.1 use formula <math>D=3.0W^{1/3}</math> with a minimum distance of 80 feet.</p> <p>-Separated for HDs 1.2 through 1.4 by a minimum distance of 80 feet.</p>	

**Table 8-6**  
**QD for unprotected aboveground service tanks supporting explosives storage or operating complexes**

NEW		Distance
Over	Not over	
0	1,000	D=400 feet
1,000	30,000	D=40W <sup>1/3</sup>
30,000	100,000	D=40W <sup>1/3</sup> or use table 8-8, column 5
100,000	250,000	D=2.42W <sup>0.577</sup> or use table 8-8, column 5
250,000	500,000	D=50W <sup>1/3</sup> or use table 8-8, column 5

**8-18. Blast tables for HD 1.1 ammunition and explosives**

Table 8-8 is used to determine the appropriate safe separation distance or permissible NEW for HD 1.1 ammunition and explosives based on the potential explosion site, NEW or distance available, use and type of exposed site, barricades and orientation.

**8-19. Fragments**

The second essential consideration in analyzing the risk associated with an explosion is the affect of the fragments generated by the explosion.

a. Fragments can be either classified as primary or secondary fragments depending on their origin. A fragment is considered as hazardous when it has an impact energy of 58 ft-lb (79 joules) or greater.

b. Primary fragments are formed as a result of the shattering of the explosive container. The container may be the casing of conventional munitions; the kettles, hoppers, and other metal containers used in the manufacture of explosives; the metal housing of rocket engines; and similar items. These fragments usually are small in size and travel initially at velocities of the order of thousands of feet per second.

c. Secondary fragments are formed as a result of high blast pressures on structural components and items in close proximity to the explosion. These fragments are somewhat larger in size than primary fragments and travel initially at velocities in the order of hundreds of feet per second.

d. Hazard class-division 1.1 and HD 1.2 both produce fragments. However, as the quantity of HD 1.1 increases about a certain amount, the affects of the blast wave represents a greater severity than the fragment hazard and therefore the blast wave is given greater weight in calculating QD. In some HD 1.1 situations, the resulting damage due to fragments can be as severe on the mission capability as the damage due to the blast.

e. In addition to fragments, firebrands can be produced. Firebrands are normally associated with HD 1.3 ammunition and explosives.

f. Fragment distance minima are to protect personnel in the open; firebrand distance minima are to protect facilities.

**8-20. Hazard division 1.1 fragments**

a. Hazard class-division 1.1 ammunition and explosives produce fragments. As the quantity of HD 1.1 increases above a certain amount, the affects of the blast wave represents a greater severity than the fragment hazard and therefore the blast wave is given greater weight in calculating QD.

b. In some HD 1.1 situations, the resulting damage due to fragments can be as severe on the mission capability as the damage due to the blast. Therefore, the fragment hazard should always be evaluated when conducting a risk assessment. Table 8-14 provides fragment distances based on NEW amounts up to 450 pounds. Above 450 pounds NEW, a maximum fragment distance of 1250 feet has been established.

c. Table 8-15 shows locations requiring the larger of either fragment distance minima or firebrand distance minima and table 8-16 shows locations where minimum fragment and firebrand distances need not be applied.

(1) The minimum distance for protection from hazardous fragments shall be based on primary and secondary fragments from the potential explosion site and the population and/or traffic density of the exposed site. It is defined as the distance at which the density of hazardous fragments becomes 1 per 600 ft<sup>2</sup>.

*Note.* This distance is not the maximum fragment range.

(2) Secondary fragments include debris such as that from structural elements of the facility and from non-confining process equipment likely to rupture into enough pieces to significantly contribute to the total number of expected fragments.

(3) Primary fragments include items such as those discussed in paragraph 8-19b and those from items listed in table 8-17.

(4) DDESB approved analyses and/or approved tests may be used to determine minimum distances for both primary

and secondary fragments. DDESB technical paper 13 is an example of a method to determine minimal distances for building debris, while DDESB technical paper 16 provides similar information to determine minimal distances for primary fragments.

(5) The minimum hazard fragment IBD for HD 1.1 will be 1250 ft, except as shown in table 8–14, table 8–15, or table 8–16. Lesser distances are permitted if supported by a structural analysis of the potential explosion site. Facilities sited at 1,235 ft or 1,245 ft per past standards will be considered to be in compliance with the 1,250 ft minimum requirement.

(6) PTRD fragment distance is 60 percent of hazard fragment distance, including distances shown in table 8–14 and table 8–17 with the exception listed in table 8–16.

(7) In the absence of appropriate analyses and/or tests, default hazardous debris distances defined below apply.

(a) In the absence of appropriate analyses and/or tests, default hazardous debris distances defined below apply. For populous locations, for example, those areas and/or functions identified in table 8–15, where military, civilian employees, dependent and/or public personnel are located, the minimum distance shall be that distance at which fragments, including debris from structural elements of the facility or process equipment, shall not exceed a hazardous fragment density of one hazardous fragment per 600 ft<sup>2</sup> (56 m<sup>2</sup>).

(b) If this distance is not known, table 8–18 will apply.

**Table 8–7  
HD 1.1 IBD and PTRD**

Distance in ft to inhabited building distance from:					Distance in ft to public traffic route from:			
NEW in lbs column 1	earth-covered magazine			Other PES	earth-covered magazine			Other PES
	Front col- umn 2 1,8	Side col- umn 3 1,8	Rear col- umn 4 2,8	column 5 <sup>3</sup>	Front col- umn 6 4,8	Side col- umn 7 5,8	Rear col- umn 8 6,8	column 9 <sup>7</sup>
1	500	250	250	See note 3	300	150	150	See note 7
5	500	250	250	See note 3	300	150	150	See note 7
10	500	250	250	See note 3	300	150	150	See note 7
20	500	250	250	See note 3	300	150	150	See note 7
30	500	250	250	See note 3	300	150	150	See note 7
40	500	250	250	See note 3	300	150	150	See note 7
50	500	250	250	See note 3	300	150	150	See note 7
100	500	250	250	See note 3	300	150	150	See note 7
150	500	250	250	See note 3	300	150	150	See note 7
200	700	250	250	See note 3	420	150	150	See note 7
250	700	250	250	See note 3	420	150	150	See note 7
300	700	250	250	See note 3	420	150	150	See note 7
350	700	250	250	See note 3	420	150	150	See note 7
400	700	250	250	See note 3	420	150	150	See note 7
450	700	250	250	See note 3	420	150	150	See note 7
500	1250	1250	1250	1250	750	750	750	750
600	1250	1250	1250	1250	750	750	750	750
700	1250	1250	1250	1250	750	750	750	750
800	1250	1250	1250	1250	750	750	750	750
900	1250	1250	1250	1250	750	750	750	750
1,000	1250	1250	1250	1250	750	750	750	750
1,500	1250	1250	1250	1250	750	750	750	750
2,000	1250	1250	1250	1250	750	750	750	750
3,000	1250	1250	1250	1250	750	750	750	750

**Table 8-7  
HD 1.1 IBD and PTRD—Continued**

4,000	1250	1250	1250	1250	750	750	750	750
5,000	1250	1250	1250	1250	750	750	750	750
6,000	1250	1250	1250	1250	750	750	750	750
7,000	1250	1250	1250	1250	750	750	750	750
8,000	1250	1250	1250	1250	750	750	750	750
9,000	1250	1250	1250	1250	750	750	750	750
10,000	1250	1250	1250	1250	750	750	750	750
15,000	1250	1250	1250	1250	750	750	750	750
20,000	1250	1250	1250	1250	750	750	750	750
25,000	1250	1250	1250	1250	750	750	750	750
30,000	1250	1250	1250	1250	750	750	750	750
35,000	1250	1250	1250	1308	750	750	750	785
40,000	1250	1250	1250	1368	750	750	750	821
45,000	1250	1250	1250	1432	750	750	750	854
50,000	1289	1289	1250	1474	774	774	750	884
55,000	1331	1331	1250	1521	799	799	750	913
60,000	1370	1370	1250	1566	822	822	750	940
65,000	1407	1407	1250	1608	844	844	750	965
70,000	1442	1442	1250	1649	865	865	750	989
75,000	1476	1476	1250	1687	886	886	750	1012
80,000	1508	1508	1250	1724	905	905	750	1034
85,000	1539	1539	1250	1759	923	923	750	1055
90,000	1568	1568	1250	1793	941	941	750	1076
95,000	1597	1597	1250	1825	958	958	750	1095
100,000	1625	1625	1250	1857	975	975	750	1114
105,000	1683	1683	1250	1910	1010	1010	750	1146
110,000	1740	1740	1287	1962	1044	1044	772	1177
120,000	1853	1853	1415	2063	1112	1112	849	1238
125,000	1908	1908	1479	2112	1145	1145	888	1267
130,000	1963	1963	1544	2161	1178	1178	926	1296
140,000	2071	2071	1674	2255	1243	1243	1004	1353
150,000	2177	2177	1804	2346	1306	1306	1083	1408
160,000	2281	2281	1936	2436	1369	1369	1162	1461
170,000	2383	2383	2068	2522	1430	1430	1241	1513
180,000	2484	2484	2201	2607	1490	1490	1321	1564
190,000	2583	2583	2335	2689	1550	1550	1401	1614
200,000	2680	2680	2469	2770	1608	1608	1481	1662
225,000	2919	2919	2807	2965	1751	1751	1684	1779
250,000	3149	3149	3149	3151	1889	1889	1889	1891
275,000	3251	3251	3251	3251	1951	1951	1951	1951
300,000	3347	3347	3347	3347	2008	2008	2008	2008
325,000	3438	3438	3438	3438	2063	2063	2063	2063
350,000	3524	3524	3524	3524	2114	2114	2114	2114

**Table 8-7**  
**HD 1.1 IBD and PTRD—Continued**

375,000	3606	3606	3606	3606	2163	2163	2163	2163
400,000	3684	3684	3684	3684	2210	2210	2210	2210
425,000	3759	3759	3759	3759	2256	2256	2256	2256
450,000	3832	3832	3832	3832	2299	2299	2299	2299
475,000	3901	3901	3901	3901	2341	2341	2341	2341
500,000	3969	3969	3969	3969	2381	2381	2381	2381

Notes:

<sup>1</sup> Basis for columns 2 and 3 distances:

<sup>2</sup> 1–450 lbs-see table 8–14.

<sup>3</sup> 451–45,000 lbs of debris hazard. Lesser distances permitted if proved sufficient to limit hazardous debris to 1 per 600 square feet. Formula  $D=35W^{1/3}$  (blast overpressure) may be used if fragments and debris are absent.

<sup>4</sup> 45,000–100,000 lbs - blast overpressure hazard. Solve for distance with  $D=35W^{1/3}$  and NEW with  $W=(D/35)^3$ .

<sup>5</sup> 100,000–250,000 lbs-blast overpressure hazard. Solve for distance with  $D=0.3955W^{0.7227}$  and NEW with  $W=(D/.3955)^{1.384}$ .

<sup>6</sup> 250,000 lbs and above - blast overpressure hazard. Solve for distance with  $D=50W^{1/3}$  and NEW with  $W=(D/50)^3$ .

<sup>7</sup> Basis for column 4 distances:

<sup>8</sup> 1–100,000 lbs - debris hazard. Lesser distances are permitted if proved sufficient to limit hazardous debris to 1 per 600 square feet. The formula  $D=25W^{1/3}$  (blast overpressure) may be used if fragments and debris are absent.  $W=(D/25)^3$ .

<sup>9</sup> 100,000–250,000 lbs - blast overpressure hazard. Solve for distance with  $D=0.004125W^{1.0898}$  and NEW with  $W=(D/.004125)^{.9176}$ .

<sup>10</sup> 250,000 lbs and above - blast overpressure hazard. Solve for distance with  $D=50W^{1/3}$  and NEW with  $W=(D/50)^3$ .

<sup>11</sup> Basis for column 5 distances:

<sup>12</sup> 1–30,000 lbs - fragments and debris hazard. Lesser distances permitted by table 8–18.

<sup>13</sup> 30,000–100,000 lbs - blast overpressure hazard. Solve for distance with  $D=40W^{1/3}$  and NEW with  $W=(D/40)^3$ .

<sup>14</sup> 100,000–250,000 lbs - blast overpressure hazard. Solve for distance with  $D=2.42W^{0.577}$  and NEW with  $W=(D/2.42)^{1.7310}$ .

<sup>15</sup> 250,000 lbs and above - blast overpressure hazard. Solve for distance with  $D=50W^{1/3}$  and NEW with  $W=(D/50)^3$ .

<sup>16</sup> Column 6 distances have the same hazard basis and are equal to 60 percent of column 2 distances.

<sup>17</sup> Column 7 distances have the same hazard basis and are equal to 60 percent of column 3 distances.

<sup>18</sup> Column 8 distances have the same hazard basis and are equal to 60 percent of column 4 distances.

<sup>19</sup> Column 9 distances have the same hazard basis and are equal to 60 percent of column 5 distances.

<sup>20</sup> Distances for NEWs between 30,000 and 250,000 lbs apply only for ECMs that are 26 ft. wide by 60 ft. long, or larger. For smaller ECMs, use other potential explosion site distances of columns 5 or 9.

<sup>21</sup> Column 2 Inhabited Building Distances apply to all directions from High Performance Magazines. The maximum credible event in the HPM is used as the NEW (Column 1). The limit on the design MCE in an HPM is 60,000 lbs.

<sup>22</sup> Column 6 Public Traffic Route Distances apply to all directions from High Performance Magazines. The maximum credible event in the HPM is used as the NEW (Column 1). The limit on the design MCE in an HPM is 60,000 lbs.

**Table 8-8**  
**HD 1.1 ILD from PESSs other than earth-covered magazines**

NEW in lbs	Barricaded $D=9W^{1/3}$ ft	Unbarricaded $D=18W^{1/3}$ ft		NEW in lbs	Barricaded $D=9W^{1/3}$ ft	Unbarricaded $D=18W^{1/3}$ ft
50 <sup>1</sup>	33	66		70,000	371	742
100	42	84		75,000	380	759
200	53	105		80,000	388	776
300	60	120		85,000	396	791
400	66	133		90,000	403	807
500	71	143		95,000	411	821
600	76	152		100,000	418	835
700	80	160		125,000	450	900
800	84	167		150,000	478	956
900	87	174		175,000	503	1,007
1,000	90	180		200,000	526	1,053
1,500	103	206		225,000	547	1,095



**Table 8–8**  
**HD 1.1 ILD from PESs other than earth-covered magazines—Continued**

NEW in lbs	Barricaded D=9W <sup>1/3</sup> ft	Unbarricaded D=18W <sup>1/3</sup> ft		NEW in lbs	Barricaded D=9W <sup>1/3</sup> ft	Unbarricaded D=18W <sup>1/3</sup> ft
2,000	113	227		250,000	567	1,134
3,000	130	260		275,000	585	1,171
4,000	143	286		300,000	602	1,205
5,000	154	308		325,000	619	1,238
6,000	164	327		350,000	634	1,269
7,000	172	344		375,000	649	1,298
8,000	180	360		400,000	663	1,326
9,000	187	374		500,000 <sup>2</sup>	714	1,429
10,000	194	388		600,000	759	1,518
15,000	222	444		700,000	799	1,598
20,000	244	489		800,000	835	1,671
25,000	263	526		900,000	869	1,738
30,000	280	559		1,000,000	900	1,800
35,000	294	589		1,500,000	1,030	2,060
40,000	308	616		2,000,000	1,134	2,268
45,000	320	640		2,500,000	1,221	2,443
50,000	332	663		3,000,000	1,298	2,596
55,000	342	685		3,500,000	1,366	2,733
60,000	352	705		4,000,000	1,429	2,857
65,000	362	724		5,000,000	1,539	3,078

Notes:

<sup>1</sup> For less than 50 pounds, lesser distances may be used when structures, blast mats, or equipment will completely contain fragments and debris. Determine distances using the formula shown.

<sup>2</sup> Quantities above 500,000 pounds are authorized only for group IV liquid propellants.

<sup>3</sup> This table is not applicable when blast, fragments, and debris are completely contained as in certain test firing barricades.

**Table 8–9**  
**HD 1.1 ILD from earth-covered magazines to the ES**

NEW in pounds	Barricaded intraline explosion coming from:			Unbarricaded intraline explosion coming from:		
	Front <sup>1</sup> (ft)	Side <sup>2</sup> (ft)	Rear <sup>3</sup> (ft)	Front <sup>4</sup> (ft)	Side <sup>5</sup> (ft)	Rear <sup>6</sup> (ft)
50	37	26	22	66	59	44
70	41	29	25	74	66	49
100	46	32	28	84	74	56
150	53	37	32	96	85	64
200	58	41	35	105	94	70
300	67	47	40	120	107	80
500	79	56	48	143	127	95
700	89	62	53	160	142	107
1,000	100	70	60	180	160	120
1,500	114	80	69	206	183	137
2,000	126	88	76	227	202	151
3,000	144	101	87	260	231	173
5,000	171	120	103	308	274	205

**Table 8–9**  
**HD 1.1 ILD from earth-covered magazines to the ES—Continued**

<b>7,000</b>	191	134	115	344	306	230
<b>10,000</b>	215	151	129	388	345	259
<b>15,000</b>	247	173	148	444	395	296
<b>20,000</b>	271	190	163	489	434	326
<b>30,000</b>	311	218	186	559	497	373
<b>50,000</b>	368	258	221	663	589	442
<b>70,000</b>	412	288	247	742	659	495
<b>100,000</b>	464	325	278	835	743	557
<b>150,000</b>	531	372	319	956	850	653
<b>200,000</b>	585	409	351	1,053	936	746
<b>300,000</b>	669	469	402	1,205	1,071	937
<b>500,000</b>	716	714	714	1,429	1,429	1,429

Notes:

- <sup>1</sup> Barricaded front.
- <sup>2</sup> Solve for required distance:
- <sup>3</sup> NEW <300,000 lbs;  $d=10 * NEW^{1/3}$
- <sup>4</sup> 300,000 lbs < NEW=500,000 lbs;  $d=(13.659 - 1.6479e-05*NEW + 1.4358e-11*NEW^2)*NEW^{1/3}$
- <sup>5</sup> Solve for NEW:
- <sup>6</sup>  $d=669$  ft;  $NEW=d^3 / 1,000$
- <sup>7</sup>  $669$  ft <  $d=715$  ft;  $NEW=1.50138e+08 - 6.73914e+05*d + 1002.9*d^2 - 0.4938*d^3$
- <sup>8</sup> Barricaded side:
- <sup>9</sup> Solve for required distance:
- <sup>10</sup> NEW <300,000 lbs;  $d=7 * NEW^{1/3}$
- <sup>11</sup> 300,000 lbs < NEW=400,000 lbs;  $d=(1.0848 + 1.986e-05*NEW)*NEW^{1/3}$
- <sup>12</sup> NEW >400,000 lbs;  $d=9 * NEW^{1/3}$
- <sup>13</sup> Solve for NEW:
- <sup>14</sup>  $d=469$  ft;  $NEW=d^3 / 343$
- <sup>15</sup>  $469$  ft <  $d=663$  ft;  $NEW=57,424 + 515.89*d$
- <sup>16</sup>  $d > 663$  ft;  $NEW=d^3/729$
- <sup>17</sup> Barricaded rear:
- <sup>18</sup> Solve for required distance:
- <sup>19</sup> NEW=300,000 lbs;  $d=6 * NEW^{1/3}$
- <sup>20</sup> 300,000 lbs < NEW=400,000 lbs;  $d=(-3.059 + 3.0228e-05*NEW)*NEW^{1/3}$
- <sup>21</sup> NEW > 400,000 lbs;  $d=9 * NEW^{1/3}$
- <sup>22</sup> Solve for NEW:
- <sup>23</sup>  $d=402$  ft;  $NEW=d^3 / 216$
- <sup>24</sup>  $402$  ft <  $d=665$  ft;  $NEW=148,160 + 379.7*d$
- <sup>25</sup>  $d > 665$  ft;  $NEW=d^3 / 729$
- <sup>26</sup> Unbarricaded front.
- <sup>27</sup> Solve for required distance:
- <sup>28</sup> NEW < 500,000 lbs;  $d=18 * NEW^{1/3}$
- <sup>29</sup> Solve for NEW:
- <sup>30</sup>  $d=1,429$  ft;  $NEW=d^3 / 5,832$
- <sup>31</sup> Unbarricaded side:
- <sup>32</sup> Solve for required distance:
- <sup>33</sup> NEW <300,000 lbs;  $d=16 * NEW^{1/3}$
- <sup>34</sup> 300,000 lbs < NEW=400,000 lbs;  $d=(9.9683 + 2.0135e-05*NEW)*NEW^{1/3}$
- <sup>35</sup> NEW > 400,000 lbs;  $d=18 * NEW^{1/3}$
- <sup>36</sup> Solve for NEW:
- <sup>37</sup>  $D=1,071$  ft;  $NEW=d^3 / 4,096$
- <sup>38</sup>  $1,071$  ft <  $d=1,328$  ft;  $NEW=-118,180 + 390.35*d$
- <sup>39</sup>  $d > 1,328$  ft;  $NEW=d^3 / 5,832$
- <sup>40</sup> Unbarricaded rear:
- <sup>41</sup> Solve for required distance:
- <sup>42</sup> NEW=100,000 lbs;  $d=12 * NEW^{1/3}$
- <sup>43</sup> 100,000 lbs < NEW=300,000 lbs;  $d=(11.521 + 1.9918e-06*NEW + 2.0947e-11*NEW^2)*NEW^{1/3}$
- <sup>44</sup> NEW > 400,000 lbs;  $d=18 * NEW^{1/3}$
- <sup>45</sup> Solve for NEW:
- <sup>46</sup>  $d=557$  ft;  $NEW=d^3 / 1,728$

**Table 8-9**  
**HD 1.1 ILD from earth-covered magazines to the ES—Continued**

<sup>47</sup> 557 ft < d=938 ft; NEW=-193,080 + 526.83\*d  
<sup>48</sup> 938 ft < d=1,328 ft; NEW=60,778 + 255.83\*d  
<sup>49</sup> d > 1,328 ft; NEW=d<sup>3</sup> / 5,832

**HD 1.1 guide for intermagazine distance (IMD) <sup>1, 5, 9</sup>**

To Exposed Site (ES) <sup>7,8</sup>		From Potential Explosion Site <sup>7,8</sup> (PES)									
		Earth-covered Magazine (ECM)				Aboveground Magazine <sup>3</sup> (AGM)		Modules and/or Cells <sup>6</sup>		HPM	
		Side	Rear	FB	FU	B	U	B	U	S	F
ECM (7-bar) <sup>2</sup>	S	1.25	1.25	2.75	2.75	4.5	4.5	4.5	4.5	1.25	2.75
	R	1.25	1.25	2	2	4.5	4.5	4.5	4.5	1.25	2
	FU	2.75	2	6	6	6	6	6	6	2.75	6
	FB	2.75	2	4.5	6	4.5	6	4.5	6	2.75	6
ECM (3-bar) <sup>2</sup>	S	1.25	1.25	2.75	2.75	6	6	6	6	1.25	2.75
	R	1.25	1.25	2	2	6	6	6	6	1.25	2
	FU	4.5	4.5	6	9	6	9	6	9	4.5	9
	FB	4.5	4.5	6	6	6	6	6	6	4.5	6
ECM Undefined <sup>2</sup>	S	1.25 <sup>4</sup> 2 <sup>5</sup>	1.25 <sup>4</sup> 2 <sup>5</sup>	4.5 <sup>4</sup> 6 <sup>5</sup>	4.5 <sup>4</sup> 6 <sup>5</sup>	6	6	6	6	1.25	4.5
	R	1.25	1.25	2	2	6	6	6	6	1.25	2
	FU	6	6	6	11	6	11	6	11	6	11
	FB	6	6	6	6	6	6	6	6	6	6
AGM <sup>3</sup>	U	6	6	6	11	6	11	6	11	6	11
	B	6	6	6	6	6	6	6	6	6	6
Modules and/or Cells <sup>6</sup>	U	6	6	6	11	6	11	1.1	11	6	11
	B	1.25	1.25	6	6	6	6	1.1	1.1	1.25	6
HPM	S <sup>10</sup>	1.25	1.25	2.75	2.75	4.5	4.5	4.5	4.5	1.25	2.75

**Notes:**

1. Unless limited elsewhere, earth-covered magazines and aboveground magazines may be used to store 500,000 lbs NEW. A module or cell is limited to 250,000 lbs NEW.
2. Descriptions of the earth-covered magazines and their limits are in appendix G.
3. Aboveground magazines are all types of above grade (non earth-covered) magazines or storage pads.
4. Use this K factor for NEW in the potential explosion site up to 250,000 lbs.
5. Use this K factor for NEW in the potential explosion site above 250,000 lbs.
6. Modules and/or cells are defined in Glossary.
7. Refer to paragraph 8-16 and figure 8-3 to determine the front, side or rear of earth-covered magazines.
8. Abbreviations used are B – barricaded, U – unbarricaded, FB – front barricaded, FU – front unbarricaded, HPM – high performance magazine, R – rear, and S – side.
9. Numbers at the intersections are the K factors used in solving for quantity-distance.
10. The storage areas in the HPM are barricaded on all sides and protected by a reinforced concrete cover. All directions are therefore considered to be side orientations when it is the exposed site. For siting purposes the HPM has no rear sector.

**Figure 8-5. HQ 1.1 guide for intermagazine distance<sup>1, 8, 9</sup>**

**Table 8–10**  
**HD 1.1 intermagazine hazard factors and distances**

NEW in pounds	Hazard factor / K factor										
	1.1	1.25	2	2.75	4.5	5	6	8	9	11	18
100	7	7	9.3	13	21	23	28	37	42	51	84
200	7	7.3	12	16	26	29	35	47	53	64	105
300	7.4	8	13	18	30	33	40	54	60	74	120
400	8.1	9.2	15	20	33	37	44	59	66	81	133
500	8.7	9.9	16	22	36	40	48	63	71	87	143
600	9.3	10.5	17	23	38	42	51	67	76	93	152
700	9.8	11	18	24	40	44	53	71	80	98	160
800	10	12	19	26	42	46	56	74	84	102	167
900	11	12	19	27	43	48	58	77	87	106	174
1,000	11	13	20	28	45	50	60	80	90	110	180
1,500	13	14	23	31	52	57	69	92	103	126	206
2,000	14	16	25	35	57	63	76	101	113	139	227
4,000	17	20	32	44	71	79	95	127	143	175	286
5,000	19	21	34	47	77	85	103	137	154	188	308
6,000	20	23	36	50	82	91	109	145	164	200	327
7,000	21	24	38	53	86	96	115	153	172	210	344
8,000	22	25	40	55	90	100	120	160	180	220	360
9,000	23	26	42	57	94	104	125	166	187	229	374
10,000	24	27	43	59	97	108	129	172	194	237	388
11,000	24	28	44	61	100	111	133	178	200	245	400
12,000	25	29	46	63	103	114	137	183	206	252	412
13,000	26	29	47	65	106	118	141	188	212	259	423
14,000	27	30	48	66	108	121	145	193	217	265	434
15,000	27	31	49	68	111	123	148	197	222	271	444
16,000	28	31	50	69	113	126	151	202	227	277	454
17,000	28	32	51	71	116	129	154	206	231	283	463
18,000	29	33	52	72	118	131	157	210	236	288	472
19,000	29	33	53	73	120	133	160	213	240	294	480
20,000	30	34	54	75	122	136	163	217	244	299	489
21,000	30	34	55	76	124	138	166	221	248	303	497
22,000	31	35	56	77	126	140	168	224	252	308	504
25,000	32	37	58	80	132	146	175	234	263	322	526
30,000	34	39	62	85	140	155	186	249	280	342	559
40,000	38	43	68	94	154	171	205	274	308	376	616
50,000	41	46	74	101	166	184	221	295	332	405	663
60,000	43	49	78	108	176	196	235	313	352	431	705
70,000	45	52	82	113	185	206	247	330	371	453	742
80,000	47	54	86	118	194	215	259	345	388	474	776
90,000	49	56	90	123	202	224	269	359	403	493	807

**Table 8-10**  
**HD 1.1 intermagazine hazard factors and distances—Continued**

100,000	51	58	93	128	209	232	278	371	418	511	835
125,000	55	63	100	138	225	250	300	400	450	550	900
150,000	58	66	106	146	239	266	319	425	478	584	956
175,000	62	70	112	154	252	280	336	447	503	615	1007
200,000	64	73	117	161	263	292	351	468	526	643	1053
225,000	67	76	122	167	274	304	365	487	547	669	1095
250,000	69	79	126	173	283	315	378	504	567	693	1134
300,000	74	84	134	184	301	335	402	536	602	736	1205
350,000	78	88	141	194	317	352	423	564	634	775	1269
400,000	81	92	147	203	332	368	442	589	663	810	1326
450,000	84	96	153	211	345	383	460	613	690	843	1379
500,000	87	99	159	218	357	397	476	653	714	873	1429
600,000	93	105	169	232	380	422	506	675	759	928	1518
700,000	98	111	178	244	400	444	533	710	799	977	1598
800,000	102	116	186	255	418	464	557	743	835	1021	1671
900,000	106	121	193	266	434	483	579	772	869	1062	1738
1,000,000	110	125	200	275	450	500	600	800	900	1100	1800
1,250,000	118	135	215	296	485	539	646	862	969	1185	1939
1,500,000	126	143	229	315	515	572	687	916	1030	1259	2060
1,750,000	133	151	241	331	542	603	723	964	1085	1326	2169
2,000,000	139	157	252	346	567	630	756	1008	1134	1386	2268
2,250,000	144	164	262	360	590	655	786	1084	1179	1441	2359
2,500,000	149	170	271	373	611	679	814	1086	1221	1493	2443
2,750,000	154	175	280	385	630	701	841	1121	1261	1541	2522
3,000,000	159	180	288	397	649	721	865	1154	1298	1586	2596
3,250,000	163	185	296	407	667	741	889	1185	1333	1629	2666
3,500,000	167	190	304	418	683	759	911	1215	1366	1670	2733
4,000,000	175	198	317	437	714	794	952	1270	1429	1746	2857
4,250,000	178	202	324	445	729	810	972	1296	1458	1782	2916
4,500,000	182	206	330	454	743	825	991	1321	1486	1816	2972
5,000,000	188	214	342	470	769	855	1026	1368	1539	1881	3078
5,500,000	194	221	353	485	794	883	1059	1412	1589	1942	3177
6,000,000	200	227	363	500	818	909	1090	1454	1635	1999	3271
6,500,000	205	233	373	513	840	933	1120	1493	1680	2053	3359
7,000,000	210	239	383	526	861	956	1148	1530	1722	2104	3443
7,500,000	215	245	391	538	881	979	1174	1566	1762	2153	3523
8,000,000	220	250	400	550	900	1000	1200	1600	1800	2200	3600
8,500,000	224	255	408	561	918	1020	1224	1633	1837	2245	3673
9,000,000	229	260	416	572	936	1040	1248	1664	1872	2288	3744
10,000,000	237	269	431	592	969	1077	1293	1724	1939	2370	3878
11,000,000	245	278	445	612	1001	1112	1334	1779	2002	2446	4003
12,000,000	252	286	458	630	1030	1145	1374	1832	2060	2518	4121
13,000,000	259	294	470	647	1058	1172	1411	1881	2116	2586	4232

**Table 8-10**  
**HD 1.1 intermagazine hazard factors and distances—Continued**

14,000,000	265	301	482	663	1085	1205	1446	1928	2169	2651	4338
15,000,000	271	308	493	678	1110	1233	1480	1973	2220	2713	4439

**Table 8-11**  
**Intermagazine separation for barricaded storage modules for mass detonating explosives**

NEW	Minimum explosives-to-explosives distance in feet (barricaded) between Cells & Modules $D=1.1W^{1/3}$	Barricade height based upon storage pad size	
		Cell Storage pad size (width or depth) in feet	Minimum height of barricade above top of stack in feet
50,000	40	30	2
100,000	50	30	2
125,000	55	30	2
150,000	60	30	2
175,000	60	30	2
200,000	65	30	2
225,000	65	40	2.5
250,000	70	40	2.5
100,000	70	50	3

**Table 8-12**  
**HD 1.1 Hazardous Fragment Distances**

NEW (pounds)	Hazardous Fragment Distance (feet)	NEW (pounds)	Hazardous Fragment Distance (feet)
=<0.5	236	75	633
1	291	80	638
2	346	85	643
3	378	90	648
4	401	95	652
5	419	100	658
6	433	125	744
8	456	150	815
10	474	175	875
15	506	200	927
20	529	225	973
25	546	250	1014
30	561	275	1051
35	573	300	1085
40	583	325	1116
45	593	350	1145
50	601	375	1172
55	609	400	1197
60	616	425	1220
65	622	450	1243

**Table 8-12**  
**HD 1.1 Hazardous Fragment Distances—Continued**

70	628	>450	1250
----	-----	------	------

Notes:

<sup>1</sup> (See para 8-20 regarding application of table 8-14.)

<sup>2</sup> To determine the hazardous fragment distance (HFD) for NEW < 100 Pounds use the formula  $HFD=291.3 + (79.2 \times \ln(NEW))$ ; where NEW in pounds, HFD in feet, with a minimum distance of 236 feet (ln is natural logarithm).

<sup>3</sup> To determine the hazardous fragment distance (HFD) for NEW > 100 Pounds use the formula  $HFD=-1133.9 + (389 \times \ln(NEW))$ ; where NEW in pounds, HFD in feet, with a minimum distance of 236 feet; ln is natural logarithm.

<sup>4</sup> To determine NEW from a known distance of 657 feet or less, use the formula  $NEW=\exp ((HFD/79.2) - 3.678)$ ; with NEW in lbs, HFD in ft; exp (x) is  $e^x$ .

<sup>5</sup> To determine NEW from a known distance between 657 and 1249 feet, use the formula  $NEW=\exp ((HFD/389) + 2.914)$ ; with NEW in lbs, HFD in ft; exp (x) is  $e^x$ .

<sup>6</sup> Use of equations given in notes (2) through (5) to determine other Hazardous Fragment Distance-NEW combinations is allowed.

<sup>7</sup> PTRD is 60 percent of Hazardous Fragment Distance.

**Table 8-13**  
**Examples of where minimum fragment distance or firebrand distance is required**

Type facility	Remarks
Administration and housing areas	
Athletic and other recreation areas	If these facilities are for the exclusive use of personnel assigned to the potential explosion site none is required.
Boundaries, garrison or installation	Unless clearly inappropriate (unsuitable terrain, government land not open to the public, and so forth). For locations where inhabited building QD arcs extend beyond garrison or installation boundary, commanders will certify that conditions do not exist for the application of inhabited building protection to the encumbered area and shall establish procedures to monitor the area for any change in that status.
Flight-line passenger service functions	
Functions, vital	If momentarily put out of action, will cause an immediate secondary hazard by reason of their failure to function.
Powerhouses, main	Providing vital utilities to a major portion of the garrison or installation.
Private vehicles parked in administrative areas	
Storehouses and shops	By reason of their vital, strategic nature, or the high intrinsic value of their contents, should not be placed at risk.

**Table 8-14**  
**Examples when minimum fragment and firebrand distances need not be applied**

Type facility	Remarks
Air defense firing batteries - separated.	
Army battalion-size or smaller delivery or ammunition supply units.	
DOD-controlled support functions.	When IMD and ILD distances are the usual protection levels.
Facilities in an operating line - between.	
Maintenance facilities for the service of the logistics and operations functions of combat aircraft.	
Operating lines - between.	
Operations offices for the service of the logistics and operations functions of combat aircraft.	
Parking areas for dead storage of military aircraft or vehicles and potential explosion site.	
Pier, single for which the ammunition in the potential explosion site is intended.	
Recreation.	If these facilities are for the exclusive use of personnel assigned to the potential explosion site.

**Table 8-14**  
**Examples when minimum fragment and firebrand distances need not be applied—Continued**

Related DOD-controlled functions.	When IMD and ILD distances are the usual protection levels.
Static inert (relatively) storage areas and potential explosion site.	
Supply facilities for the service of the logistics and operations functions of combat aircraft.	
Training facilities for the service of the logistics and operations functions of combat aircraft.	
Training facilities.	
Wharf, single, for which the ammunition in the potential explosion site is intended.	

**Table 8-15**  
**Hazardous fragment distances for open stacks of selected hazard division 1.1 items<sup>6</sup>**

Nomenclature <sup>a</sup>	Number of Units									
	1	2	3	4	5	6	7	8	9	10
Sparrow, AIM-7 <sup>b</sup>	280	565	770	955	1120	1245				
Sidewinder, AIM-9	400	400	400	400	400	400	400	400	400	400 <sup>1</sup>
Chaparral, MIM-72H	400	400	400	400	400	400	400	400	400	400 <sup>1</sup>
Maverick, AGM 65 A/B/D	400	500	500							
Maverick, AGM 65 E/F/G	670	900 <sup>2</sup>	1200 <sup>2</sup>							
ASROC	500	500	500							
CBU-87*	800	800	910	945	965	982	1000	1020	1035	1055 <sup>3</sup>
Improved Hawk	900	900	900	900	900	900	900	900	900	900
Penguin*	500	500	500							
Projectile, 105 mm, M1 <sup>c</sup>	340	355	525	660	725	775	810	845	870	890 <sup>3</sup>
Projectile, 155 mm, M107	415	590	770	955	1035	1095	1145	1195	1235	
Projectile, 5"/54	300	375	475	570	680	790	860	925	1005	1085
Harpoon*	500	600 <sup>4</sup>	600 <sup>4</sup>	600 <sup>4</sup>						
Tomahawk*	500	600 <sup>4</sup>	600 <sup>4</sup>	600 <sup>4</sup>						
Bomb, 500-pound, MK 82	670									
Bomb, 1000-pound, MK 83	815									
Bomb, 2000-pound, MK 84	925									
Bomb, BLU-109	880									
Bomb, 750-pound, M117	690									
Torpedo, MK 46	500	500	500	500	500	500	500	500		
Torpedo, MK 48 <sup>d</sup>	630	775	875							



**Table 8-15**  
**Hazardous fragment distances for open stacks of selected hazard division 1.1 items<sup>6</sup>—Continued**

Torpedo, MK 48 with shield <sup>d,e</sup>	500	500	550	600	635	670	700	725	755	780 <sup>3</sup>
---	-----	-----	-----	-----	-----	-----	-----	-----	-----	------------------

Legend for Table 8-15:

General comments for table 8-17:

- a. Items identified by an asterisk "\*" include fragments from shipping or storage container(s). However, all of the HFD in this table may be applied to both packaged and unpackaged configurations.
- b. Those items with WAU-17 warhead.
- c. 105-mm projectiles and 105-mm complete rounds not in standard storage or shipping containers are HD 1.1.
- d. All models (MOD) (includes advanced capabilities torpedoes (ADCAP).
- e. Sandbag shield is required only during handling of torpedoes from motor vehicles. Sandbag shield requirement is equivalent to a minimum thickness of 2-feet (0.61 m) of sand between the motor vehicle cab and the torpedo(es). The sandbags must shield all parts of the motor vehicle cab from the torpedo warhead. The barricade is not required during handling from boats, torpedo transporters, forklifts, or portable cranes.

Notes:

<sup>1</sup> Ten unit or more until the point is reached at which this distance is exceeded by the distance requirements of table 8-8.

<sup>2</sup> Use the distance shown only where there are less than 25 unrelated people exposed in any arc encompassing 45 degrees from 900 ft (274 m) to 1250 ft (381 m) from the potential explosion site.

<sup>3</sup> More than 10 units may be involved before 1250 ft (381 m) is exceeded. For distances involving more than 10 units consult the applicable Service guidance.

<sup>4</sup> When handling more than one missile, the missiles must be transported or handled in a nose-to-tail configuration and in their launch capsule or shipping container; furthermore, they must be aligned and/or handled so that each group of two missiles is located outside of the warhead fragment beam spray region of the other two missiles.

**Table 8-16**  
**Unknown Fragment Distance for HD 1.1**

Structure	Load Density <sup>1</sup>	Distance Table	
<b>Hazard fragment distance for Hazard Division 1.1 NEWs in quantities=450 lbs</b> (hazard fragment distance equates to IBD) (Criteria for populous locations)			
Earth-covered magazine (7-Bar or 3-Bar)		Table 8-8 (use "Earth-Covered Magazine" distances)	
Undefined earth-covered magazine	≤0.028 lbs/ft <sup>3</sup>	Table 8-8 (use "Earth-Covered Magazine" distances)	
Undefined earth-covered magazine	>0.028 lbs/ft <sup>3</sup>	Table 8-8, earth-covered magazine distances for side and rear distances. The greater of table 8-8, for earth-covered magazine front exposure or the hazard fragment distance from table 8-14 for the NEW in earth-covered magazine.	PTRD: 60 percent of IBD or hazard fragment distance, as applicable.
Earth-covered magazine (designed/analyzed, and tested to have a reduced IBD and approved by DDESB)		Use approved IBD	PTRD: 60 percent of IBD
Structure capable of stopping primary fragments but can contribute to the debris hazard (excluding earth-covered magazine) <sup>2</sup>		Table 8-22, use hazardous debris	PTRD: see table 8-22
In the open or incapable of stopping primary fragments		hazard fragment distance listed in table 8-14	
<b>HDF for Hazard Division 1.1 NEWs in ranges 451-30,000 lbs.</b> PTRD is 60 percent of hazard fragment distance			
Bare explosives in the open <sup>2</sup>		Table 8-8 (use "Earth-Covered Magazine" distances), see paragraph 8-14c or 8-14d	
Earth-covered magazine (7-Bar or 3-Bar)		Table 8-8 (use "Earth-Covered Magazine" distances)	
Undefined earth-covered magazine	≤0.028 lbs/ft <sup>3</sup>	Table 8-8 (use "Earth-Covered Magazine" distances)	
Undefined earth-covered magazine with internal dimensions=26 feet wide by 60 feet long.		Table 8-8, earth-covered magazine distances for side and rear distances-use table 8-8, and "Other potential explosion site" distances of table 8-8 for the front exposures.	
Undefined earth-covered magazine with internal dimensions >26 feet wide by 60 feet long.	>0.028 lbs/ft <sup>3</sup>	Use table 8-8, "Other potential explosion site" distances for front, side, and rear exposures.	

**Table 8-16**  
**Unknown Fragment Distance for HD 1.1—Continued**

<b>Hazard fragment distance for Hazard Division 1.1 NEWs in range &gt;30,000–250,000 lbs.</b> (PTRD is 60 percent of hazard fragment distance. Intraline criteria in accordance with paragraph 8-15c or 8-15d.)		
Bare explosives in the open <sup>2</sup>		Table 8-8 (use "Earth-Covered Magazine" distances), see paragraph 8-14b. Intraline criteria, as applicable. Note: Lesser distances are permitted if supported by a structural analysis.
Earth-covered magazine (7-Bar or 3-Bar) with internal dimensions ≥26 feet wide by 60 feet long		Table 8-8 (use "Earth-Covered Magazine" distances)
Earth-covered magazine (7-Bar or 3-Bar) with internal dimensions <26 feet wide by 60 feet long		Use table 8-8, "Other potential explosion site" distances for front, side, and rear exposures.
Undefined earth-covered magazine with internal dimensions ≥26 feet wide by 60 feet long		Table 8-8, earth-covered magazine distances for side and rear distances-use table 8-8, and "Other potential explosion site" distances of table 8-8 for the front exposures.
Undefined earth-covered magazine with internal dimensions <26 feet wide by 60 feet long		Use table 8-8, "Other potential explosion site" distances for front, side, and rear exposures.

Notes:

<sup>1</sup> Load Density=(NEW (lbs)/internal magazine volume (ft<sup>3</sup>)).

<sup>2</sup> For bare explosive in the open, distance is computed by the formula  $d=40W^{1/3}$ .

<sup>3</sup> The minimum hazard fragment distance will be 1250 ft. as shown in table 8-8. Lesser distances permitted if supported by structural analysis. Facilities sited at 1235 ft. or 1245 ft. per past standards will be in compliance with the 1250 ft. minimum requirement.

<sup>4</sup> Selected items have been evaluated for minimum hazard fragment distance with results shown in table 8-17.

<sup>5</sup> Other items, through testing, have been hazard classified with a specific hazard fragment distance presented in the format HD (xx) 1.1. The hazard fragment distance for these items is specified in hundreds of feet (in parenthesis), and they may not be listed in table 8-17. The distances for these two categories of select items apply only to items in the open. PTRD is 60 percent of hazard fragment distance. When these items are placed in a facility, apply the criteria of Hazard fragment distance for HD 1.1 NEWs in quantities=450 lbs above, as appropriate.

d. Structures (other than earth-covered magazine) that are capable of stopping primary fragments include all heavy wall (H) and heavy wall/roof (H/R) aboveground sites (AGS), as defined in the legend, located at bottom table 8-20. All other structures (other than earth-covered magazine) are considered incapable of stopping primary fragments.

e. Items, through testing, have been hazard classified with a specific hazard fragment distance presented in the format HD (xx) 1.1. The hazard fragment distance for these items is specified in hundreds of feet (in parenthesis), and they may not be listed in table 8-17. The distances for these select items apply only to items in the open. When in facilities, secondary debris as well as primary fragments must be considered. If in a facility that can contain primary fragments, apply criteria of table 8-3 category "A" above. If in a facility that cannot stop primary fragments, use the greater distance from table 8-17 (for the item being considered) or the hazard fragment distance associated with the (xx)1.1 item or from table 8-14 for determining the applicable hazard fragment distance. Intraline criteria will be in accordance with paragraph 8-15c and d.

f. Selected items have been evaluated for minimum hazard fragment distance with results shown in table 8-17. The distances of select items apply only to items in the open. When these items are placed in a facility, apply the criteria of table 8-3 category "A," above. If in a facility that cannot stop primary fragments, use the greater distance from table 8-17 (for the item being considered) or from table 8-14 for determining the applicable hazard fragment distance. Intraline criteria will be in accordance with paragraph 8-15c and d.

g. Hazard Class/Division 1.2 Items. The quantity and distances specified for HD 1.2 ammunition provides minimum protection against immediate hazards from an incident.

Note. Events involving HD1.2 items lob large amounts of unexploded rounds, components, and subassemblies, which will remain hazardous after impact. Such items are likely to be more hazardous than in their original state because of possible damage to fuse safety devices or other features by heat and impact. Many types of ammunition contain submunitions, which can be projected out to distances as great as the relevant inhabited building distances. Furthermore, it is impractical to specify quantity and distances, which allow for the maximum possible flight ranges of propulsive items.

(1) Table 8-19 explains how to determine the QD for HD 1.2 and the appropriate HD when different subgroups of HD 1.2 ammunition and explosives are stored together.

(2) Table 8-20 is the summary table for HD 1.2 items. Tables 8-21, 8-22, and 8-23 provide the appropriate IBD, PTRD, and ILD for HD 1.2.1 and HD 1.2.2 ammunition, respectively, when stored in above ground facilities. Table 8-20 provides distance requirements from earth-covered magazine storage as well as intermagazine separation requirements.

(a) When HD 1.2.1 items with an MCE greater than 31 pounds are stored in structures which may contribute to the

debris hazard, the IBD, PTRD, and ILD is determined by applying the larger of the following two distances shown in table 8–21 for the appropriate Explosive Weight (number of items x NEWQD), or that given in table 8–22 for the appropriate MCE.

(b) IMDs are dependent upon the types of structures acting as both the Potential Explosion Site (potential explosion site) and the Exposed Site (exposed site). Table 8–20 provides a matrix of all the appropriate separations for the various combinations of exposed site and potential explosion site.

(c) PTRDs provided in tables 8–21 through 8–23 give consideration to the transient nature of the exposure in the same manner as for HD 1.1. PTRD is computed as 60 percent of the IBD for items in this hazard division, with a minimum distance equal to the IMD given in table 8–20.

(d) ILD given in tables 8–21 through 8–23 take into account the progressive nature of explosions involving these items (normally resulting from fire spread), up to the magnitude of the MCE, and the ability to evacuate personnel from endangered areas before the progression involves large numbers of items. Exposed structures may be extensively damaged by projections and delayed propagation of explosions may occur due to the ignition of combustibles by projections. ILD is computed as 36 percent of the IBD for items of this HD, with a minimum distance equal to the IMDs given in table 8–20.

**Table 8–17**  
**HD 1.2.1, 1.2.2, and 1.2.3 Mixing Rules**

HAZARD SUBDIVISION INVOLVED	DISTANCES TO BE APPLIED
1.2.1 <sup>3</sup>	Apply HD 1.2.1 Distances
1.2.2 <sup>4</sup>	Apply HD 1.2.2 Distances
1.2.3 <sup>5</sup>	Apply HD 1.2.3 Distances
1.2.1 + 1.2.2	Apply greater of two distances (Non-additive)
1.2.1 + 1.2.3	Apply greater of two distances
1.2.2 + 1.2.3	Apply greater of two distances
1.2.1 + 1.2.2 + 1.2.3	Apply greatest of three distances

Notes:

<sup>1</sup> List of items (examples only): Non-mass-detonating HE–Loaded projectiles, fixed and semi-fixed ammunition, and rockets and rocket heads.

<sup>2</sup> Items of this category present a risk of propagation to adjacent aboveground magazines, particularly when packed in combustible containers. Storage in earth-covered magazines is therefore preferred.

<sup>3</sup> Earth-covered buildings may be used to their physical capacity for this category of material provided they comply with the construction and siting requirements for HD 1.1 material.

<sup>4</sup> HD 1.2.1 distances given in table 8–21, 8–22, and 8–24.

<sup>5</sup> HD 1.2.2 distances given in table 8–23 and 8–24.

<sup>6</sup> HD 1.2.3 distances given in table 8–25.

**Table 8–18**  
**Summary of HD 1.2.1, 1.2.2 and 1.2.3 Quantity-Distance Requirements**

To Exposed Site	From Potential Explosion Site				
	Earth-covered Magazine		Above-ground Site		
	Side or Rear	Front	Heavy Wall	Heavy Wall & Roof	Light structure (open stack, truck, trailer, rail car)
7 Bar or 3 Bar Earth-covered Magazine IMD	All Sides	Prudent Fire Protection & Security Distance			
Undefined earth-covered Magazine IMD	Side - Rear - Barricaded Front	Prudent Fire Protection & Security Distance			
	Unbarricaded Front	Prudent Fire Protection & Security Distance	200/300/100 200 feet for HD 1.2.1 with an MCE < 100 pounds 300 feet for HD 1.2.1 with an MCE ≥ 100 pounds 100 feet for HD 1.2.2		

**Table 8-18  
Summary of HD 1.2.1, 1.2.2 and 1.2.3 Quantity-Distance Requirements—Continued**

Above-ground Site (H/R) IMD	Barricaded or Unbarricaded	Prudent Fire Protection & Security Distance	
Above-ground Site (H or L) IMD	Barricaded or Unbarricaded	Prudent Fire Protection & Security Distance	200/300/100 200 feet for HD 1.2.1 with an MCE < 100 pounds 300 feet for HD 1.2.1 with an MCE >=100 pounds 100 feet for HD 1.2.2
ILD (For 1.2.3 see para 8-20.g(2)(e))		Prudent Fire Protection & Security Distance	36 percent of Inhabited Building Distance with a minimum distance equal to the IMD given in this table for the applicable potential explosion site to exposed site combination.
Public Traffic Route Distance (PTRD) (For 1.2.3 see para 8-20.g(2)(e))		200/300/100	60 percent of Inhabited Building Distance with a minimum distance equal to the IMD given in this table for light structures, open stacks, trucks, trailers, or rail cars. Such structures are designated as AGS (L).
IBD (For 1.2.3 see para 8-20.g(2)(e))		200/300/100	HD 1.2.1 items in any structure, truck, trailer, or railcar, use the larger of the two applicable values given in tables 8-21 and 8-22; for HD 1.2.1 items in the open use table 8-21 only; and for HD 1.2.2 items use table 8-23.

Legend for Table 8-18:

AGS (H) - Aboveground structure, Heavy Wall; Buildings with wall thickness=12 inches of reinforced concrete; as an exposed site, door must be barricaded if it faces a potential explosion site.

AGS (H/R) - Aboveground structure, Heavy Wall and Roof; AGS (H) with roof thickness> 5.9 inches of reinforced concrete; as an exposed site, door must be barricaded if it faces a potential explosion site; side/rear exposures may or may not be barricaded.

AGS (L)- Aboveground structure, Light; Light structure, open stack, truck, trailer, or railcar (open stacks - For HD 1.2.1 items in any structure, truck, trailer, or railcar, use the larger of the two applicable values given in tables 8-21 and 8-22; for HD 1.2.1 items in the open use table 8-21; for HD 1.2.2 items use table 8-23.

General Comments:

1. When the NEWQD and the MCE of the packaged HD 1.2.1 items fall within the ranges specified in equation (NEWQD < MCE < 450 lbs (204 kg)), the HD 1.2.1 shall be treated as HD 1.1.

2. For potential explosion site-exposed site combinations where three distances are given: the first refers to a potential explosion site containing HD 1.2.1 AE with an MCE < 100 lbs (45.4 kg); the second to a potential explosion site containing HD 1.2.1 AE with an MCE >100 lbs (45.4 kg); and the third refers to a potential explosion site containing HD 1.2.2 AE. Where three IMD are given, the IMD from a potential explosion site containing only HD 1.2.3 AE to an exposed site containing other than HD 1.2.3 is K11 (4.36) based on the NEWQD of a single round of the largest (greatest NEWQD) HD 1.2.3 AE in the potential explosion site. For an exposed site containing only HD 1.2.3 items, the IMD from any potential explosion site to such an exposed site is 0 feet with consideration given to prudent fire protection and security requirements.

(e) The IBD for Unit Risk HD 1.2 ( HD 1.2.3) is determined using table 8-25 (HD 1.3 Quantity-Distances) for the NEWQD of the HD 1.2.3 item multiplied by the number of rounds present, but with a minimum IBD determined as follows:

1. If the items are in a structure that can interrupt primary fragments and can contribute debris, the minimum IBD is the hazardous debris distance given in table 8-26 for an MCE equal to the NEWQD of a single round.

2. If the items are in the open or in a light structure that will not interrupt primary fragments, the minimum IBD is the hazardous primary fragment distance based on the HD 1.1 hazardous fragment a real number density criteria applied to a single HD 1.2.3 item. The hazardous fragment distance applicable to items in the open is specified in hundreds of feet in parentheses as “(xx) HD 1.2.3.” PTRD for HD 1.2.3 is equal to 60 percent of IBD. ILD is computed as 36 percent of IBD, with a minimum distance equal to the IMD. IMD is given in table 8-20.

3. For any specific quantity or distance determination, as an alternative to the preceding HD 1.2.3 QD criteria, when an increase in the allowable quantity or a reduction in the required distance will result, items hazard classified as HD 1.2.3 may be treated as follows:

a. If the single-round NEWQD is greater than 1.6 pounds, consider the items as HD 1.2.1 (use the total NEWQD present, with an MCE equal to the NEWQD of one round).

b. If the single-round NEWQD is equal to or less than 1.6 pounds, consider the items as HD 1.2.2, based on the total NEWQD present.

c. Table 8-21 HD 1.2.1 IBD, PTRD, and ILD QD.

**Table 8–19**  
**HD 1.2.1 IBD, PTRD, and ILD QD**

Explosive weight (lbs) <sup>1</sup>	IBD <sup>2,3,4,7,8</sup> (ft)	PTR <sup>5,7,8</sup> (ft)	IL <sup>6,7,8</sup> (ft)	Explosive weight (lbs) <sup>1</sup>	IBD <sup>2,3,4,7,8</sup> (ft)	PTR <sup>5,7,8</sup> (ft)	IL <sup>6,7,8</sup> (ft)
				7,000	1,033	620	372
2	200 <sup>9</sup>	200 <sup>9</sup>	200 <sup>9</sup>	8,000	1,055	633	380
5	200 <sup>9</sup>	200 <sup>9</sup>	200 <sup>9</sup>	9,000	1,074	644	387
10	200 <sup>9</sup>	200 <sup>9</sup>	200 <sup>9</sup>	10,000	1,091	654	393
20	200 <sup>9</sup>	200 <sup>9</sup>	200 <sup>9</sup>	15,000	1,154	693	416
40	200 <sup>9</sup>	200 <sup>9</sup>	200 <sup>9</sup>	20,000	1,199	719	432
60	200 <sup>9</sup>	200 <sup>9</sup>	200 <sup>9</sup>	25,000	1,233	740	444
80	224	200 <sup>9</sup>	200 <sup>9</sup>	30,000	1,260	756	454
100	268	200 <sup>9</sup>	200 <sup>9</sup>	40,000	1,303	782	469
150	348	209 <sup>10</sup>	200 <sup>9</sup>	50,000	1,335	801	481
200	404	242 <sup>10</sup>	200 <sup>9</sup>	60,000	1,362	817	490
300	481	289 <sup>10</sup>	200 <sup>9</sup>	70,000	1,384	830	498
400	535	321	200 <sup>9</sup>	80,000	1,402	841	505
600	610	366	220 <sup>10</sup>	90,000	1,419	851	511
800	662	397	238 <sup>10</sup>	100,000	1,434	860	516
1,000	702	421	253 <sup>10</sup>	150,000	1,489	894	536
1,500	774	464	279 <sup>10</sup>	200,000	1,528	917	550
2,000	824	494	297 <sup>10</sup>	250,000	1,558	935	561
2,500	862	517	310	300,000	1,582	949	569
3,000	893	536	322	350,000	1,601	961	577
3,500	919	551	331	400,000	1,619	971	583
4,000	941	565	339	450,000	1,633	980	588
5,000	978	587	352	500,000	1,647	988	593
6,000	1,008	605	363	>500,000	Note 4	Note 5	Note 6

Notes:

<sup>1</sup> Explosive Weight=Number of Items x NEWQD.

<sup>2</sup>  $IBD = 735.186 + (237.559 \times (\ln(\text{Number of items} \times \text{NEWQD}))) - (4.274 \times (\ln(\text{Number of items} \times \text{NEWQD}) - 2))$  with a minimum of 200 feet; IBD in feet, NEWQD in pounds; ln is natural logarithm. (71 < explosive weight).

<sup>3</sup> Number of items x NEWQD=exp (27.791 - (600.392 - 0.234 x IBD) 1/2); IBD in feet, NEWQD in pounds; exp (x) is ex. (200 < IBD < 2016).

<sup>4</sup> Use of equations given in Notes (2) and (3) to determine other IBD-weight combinations is allowed.

<sup>5</sup> PTRD=60 percent of IBD with a minimum distance equal to the IMD given in table 8–20, for light structures, open stacks, trucks, trailers, or rail cars. Such structures are designated as AGS (L) in table 8–20. For other structures as either exposed site or potential explosion site, see table 8–20.

<sup>6</sup> ILD=36 percent of IBD with a minimum distance equal to the IMD given in table 8–20, for the applicable potential explosion site-exposed site combination. For structures other than AGS (L) as either exposed site or potential explosion site, see table 8–20.

<sup>7</sup> The quantity-distance criteria for HD 1.2.1 items are based on the hazards from primary fragments. When stored in structures which may contribute to the debris hazard (secondary fragments), the IBD for HD 1.2.1 items whose MCE is greater than 31 pounds is determined by using the larger of the following two distances: those given in this table for the appropriate Explosive Weight or those given in table 8–22 for the appropriate MCE. Structures that may contribute to the debris hazard for storage of HD 1.2.1 ammunition include:

<sup>8</sup> All earth-covered magazines (ECMs) - Frontal exposure only. Side and rear exposures have fixed minimum distances for IBD, PTRD, and ILD;

<sup>9</sup> All aboveground sites (AGSs)-Including heavy wall (H), heavy wall/roof (H/R), and light wall (L) as defined in table 8–20, unless data/analyses are provided to show that the structural debris contribution is less. Note that ILD and PTRD are based on 36 percent and 60 percent, respectively, of the applicable IBD as determined in this note with the following minimum distances: ILD minimum distances are given in table 8–20 for applicable potential explosion site-exposed site combinations and PTRD minimum distances are given in table 8–20 for AGS (L).

<sup>10</sup> See table 8–20 for a summary of IMD and minimum distances for ILD and PTRD.

<sup>11</sup> 200 feet if MCE=100 pounds.

<sup>12</sup> 300 feet if MCE > 100 pounds.

**Table 8–20**  
**Minimum fragment distances for HD 1.2.1 items stored in structures, which can contribute to the debris hazard**

MCE (lbs)	Hazardous Debris Distance (IBD) <sup>1,2</sup> (ft)	PTR <sup>4</sup> (ft)	IL <sup>5</sup> (ft)
<31	200	200	200
35	249	200	200
40	301	200	200
45	347	208	200
50	388	233	200
75	546	328	200
100	658	395	237
125	744	446	268
150	815	489	293
175	875	525	315
200	927	556	334
225	973	584	350
250	1,014	608	365
275	1,051	631	378
300	1,085	651	391
325	1,116	670	402
350	1,145	687	412
375	1,172	703	422
400	1,197	718	431
425	1,220	732	439
450	1,243	746	447
>450	1,250	750	450

Notes:

<sup>1</sup> Hazardous Debris Distance= $-1133.9 + (389 \times \ln(\text{MCE}))$ ; (31 < MCE <450) MCE in pounds, Hazardous Debris Distance in feet with a minimum distance of 200 feet; ln is natural logarithm.

<sup>2</sup>  $\text{MCE} = \exp((\text{Hazardous Debris Distance}/389) + 2.914)$ ; (200 < Hazardous Debris Distance < 1250) MCE in pounds, Hazardous Debris Distance in feet; exp (x) is  $e^x$ .

<sup>3</sup> Use of equations given in Notes (1) and (2) to determine other Hazardous Debris Distance-MCE combinations are allowed.

<sup>4</sup> PTRD=60 percent of IBD with a minimum distance equal to the IMD given in table 8–20. For light structures, open stacks, trucks, trailers, or rail cars. Such structures are designated as AGS (L) in table 8–20. For other structures as either exposed site or potential explosion site, see table 8–20.

<sup>5</sup> ILD=36 percent of IBD with a minimum distance equal to the IMD given in table 8–20. For the applicable potential explosion site-exposed site combination. For structures other than AGS (L) as either exposed site or potential explosion site, see table 8–20.

<sup>6</sup> The quantity-distance criteria for HD 1.2.1 items are based on the hazards from primary fragments. When stored in structures which may contribute to the debris hazard (secondary fragments), the IBD, PTRD, and ILD for HD 1.2.1 items whose MCE is greater than 31 pounds is determined by using the larger of the following two distances: those given in table 8–21 for the appropriate Explosive Weight or those given in this table for the appropriate MCE. Structures that may contribute to the debris hazard for storage of HD 1.2.1 ammunition include:

<sup>7</sup> All earth-covered magazines (ECMs) - Frontal exposure only. Side and rear exposures have fixed minimum distances for IBD, PTRD, and ILD;

<sup>8</sup> All aboveground sites (AGSs)-Including heavy wall (H), heavy wall/roof (H/R), and light wall (L) as defined table 8–20, unless data/analyses are provided to show that the structural debris contribution is less. Note that ILD and PTRD are based on 36 percent and 60 percent, respectively, of the applicable IBD as determined in this note with the following minimum distances: ILD minimum distances are given in table 8–20 for applicable potential explosion site-exposed site combinations and PTRD minimum distances are given in table 8–20 for AGS (L).

<sup>9</sup> See table 8–20 for a summary of IMD and minimum distances for ILD and PTRD.

**Table 8–21**  
**HD 1.2.2 IBD, PTRD, and ILD QD**

Explosive weight (lbs) <sup>1</sup>	IBD <sup>2,3,4</sup> (ft)	PTR <sup>5</sup> (ft)	IL <sup>6</sup> (ft)		Explosive weight (lbs) <sup>1</sup>	IBD <sup>2,3,4</sup> (ft)	PTR <sup>5</sup> (ft)	IL <sup>6</sup> (ft)
1	100	100	100		7,000	366	220	132
2	100	100	100		8,000	376	226	135
5	100	100	100		9,000	385	231	139
10	100	100	100		10,000	394	236	142
20	100	100	100		15,000	427	256	154
40	113	100	100		20,000	451	271	162
60	123	100	100		25,000	471	282	169
80	131	100	100		30,000	487	292	175
100	138	100	10		40,000	514	308	185
150	152	100	100		50,000	535	321	193
200	162	100	100		60,000	553	332	199
300	179	107	100		70,000	568	341	204
400	192	115	100		80,000	581	349	209
600	211	127	100		90,000	593	356	214
800	226	136	100		100,000	604	362	217
1,000	238	143	100		150,000	647	388	233
1,500	262	157	100		200,000	678	407	244
2,000	279	168	101		250,000	703	422	253
2,500	294	176	106		300,000	72	434	260
3,000	306	183	110		350,000	741	445	267
3,500	316	190	114		400,000	757	454	272
4,000	325	195	117		450,000	771	462	277
5,000	341	205	123		500,000	783	470	282
6,000	355	213	128		>500,000	Note 4	Note 5	Note 6

Notes:

<sup>1</sup> Explosive Weight=Number of Items x NEWQD.

<sup>2</sup>  $(IBD=101.649 - (15.934 \times (\ln (\text{Number of items} \times \text{NEWQD}))) + (5.173 \times (\ln (\text{Number of items} \times \text{NEWQD}))^2)$ , with a minimum of 100 feet; IBD in feet, NEWQD in pounds; ln is natural logarithm. (20 < Explosive Weight).

<sup>3</sup> Number of items x NEWQD= $\exp (1.5401 + (-17.278 + 0.1933 \times \text{IBD}) / 2)$ ; IBD in feet, NEWQD in pounds; exp (x) is ex. ((100 < IBD < 1240).

<sup>4</sup> Use of equations given in Notes (2) and (3) to determine other IBD-weight combinations is allowed.

<sup>5</sup> PTRD=60 percent of IBD with a minimum distance equal to the IMD given in table 8–20. For light structures, open stacks, trucks, trailers, or rail cars. Such structures are designated as AGS (L) in table 8–20. For ECMs see table 8–20.

<sup>6</sup> ILD=36 percent of IBD with a minimum distance equal to the IMD given in table 8–20 for the applicable potential explosion site-exposed site combination. For structures other than AGS (L) as either exposed site or potential explosion site, see table 8–24.

<sup>7</sup> The quantity-distance criteria for HD 1.2.2 items are based on the hazards from primary fragments.

<sup>8</sup> See table 8–20 for a summary of IMD and minimum distances for ILD and PTRD.

## 8–21. Firebrands

In addition to fragments, firebrands can be produced. Firebrands are normally associated with HD 1.3 ammunition and explosives.

a. HD 1.3 includes items that burn vigorously and cannot usually be extinguished in storage situations. Explosions normally will be confined to pressure ruptures of containers and will not produce propagating shock waves or damaging blast overpressure beyond the magazine distance specified in table 8–24.

b. Tossing about of burning container materials, propellant, or other flaming debris may cause a severe hazard of spreading fire.

c. For HD 1.3 items, a parenthetically indicated fragment distance is provided only for those 1.3 items capable of

producing fragments. Unlike HD 1.1, a fragment distance is not applied to HD 1.3 items with metal casings which lack a parenthetically indicated distance. Otherwise consider HD 1.3 items as producing firebrands.

**Table 8–22**  
**Firebrand distances for HD 1.3 QD**

NEW (lbs)	IBD and PTRD <sup>5</sup> (feet)	Above-ground magazine distance <sup>7</sup> and ILD <sup>6</sup> (feet)		NEW (lbs)	IBD and PTRD <sup>5</sup> (feet)	Above-ground magazine distance <sup>7</sup> and ILD <sup>6</sup> (feet)		NEW (lbs)	IBD and PTRD <sup>5</sup> (feet)	Above-ground magazine distance <sup>7</sup> and ILD <sup>6</sup> (feet)
1,000	75	50		92,000	296	196		540,000	618	409
2,000	86	57		94,000	297	197		550,000	623	411
3,000	96	63		96,000	298	198		560,000	627	413
4,000	106	69		98,000	299	199		570,000	632	415
5,000	115	75		100,000	300	200		580,000	636	418
6,000	123	81		110,000	307	205		590,000	641	420
7,000	130	86		120,000	315	210		600,000	645	422
8,000	137	91		130,000	322	215		610,000	649	424
9,000	144	96		140,000	330	220		620,000	654	426
10,000	150	100		150,000	337	225		630,000	658	428
12,000	159	105		160,000	345	230		640,000	662	430
14,000	168	111		170,000	352	235		650,000	667	432
16,000	176	116		180,000	360	240		660,000	671	435
18,000	183	120		190,000	367	245		670,000	675	437
20,000	190	125		200,000	375	250		680,000	679	439
22,000	195	130		210,000	383	255		690,000	684	441
24,000	201	134		220,000	390	260		700,000	688	443
26,000	206	138		230,000	398	265		710,000	692	445
28,000	210	142		240,000	405	270		720,000	696	447
30,000	215	145		250,000	413	275		730,000	700	449
32,000	219	147		260,000	420	280		740,000	704	451
34,000	224	149		270,000	428	285		750,000	708	453
36,000	228	151		280,000	435	290		760,000	712	455
38,000	231	153		290,000	443	295		770,000	716	457
40,000	235	155		300,000	450	300		780,000	720	459
42,000	238	157		310,000	458	305		790,000	724	461
44,000	242	159		320,000	465	310		800,000	728	463
46,000	245	161		330,000	473	315		810,000	732	465
48,000	247	163		340,000	480	320		820,000	735	467
50,000	250	165		350,000	488	325		830,000	739	469
52,000	252	167		360,000	495	330		840,000	743	471
54,000	254	169		370,000	503	335		850,000	747	472
60,000	260	175		380,000	510	340		860,000	750	474
62,000	262	177		390,000	518	345		870,000	754	476
64,000	264	180		400,000	525	350		880,000	758	478
66,000	266	182		410,000	533	355		890,000	761	480



**Table 8-22**  
**Firebrand distances for HD 1.3 QD—Continued**

68,000	268	183		420,000	541	361		900,000	765	482
70,000	270	185		430,000	549	366		910,000	769	484
72,000	272	186		440,000	556	371		920,000	772	486
74,000	274	187		450,000	564	376		930,000	776	487
76,000	276	188		460,000	571	381		940,000	779	489
78,000	278	189		470,000	579	386		950,000	783	491
80,000	280	190		480,000	586	391		960,000	786	493
82,000	284	191		490,000	593	395		970,000	790	495
84,000	287	192		500,000	600	400		980,000	793	496
86,000	290	193		510,000	605	402		990,000	797	498
88,000	293	194		520,000	609	404		1,000,000	800	500
90,000	295	195		530,000	614	407				

Notes:

<sup>1</sup> For quantities less than 1,000 pounds the required distances are those specified for 1,000 pounds. The use of lesser distance may be approved when supported by test data and/or analysis.

<sup>2</sup> Linear interpolation of NEW quantities between table entries is permitted.

<sup>3</sup> For quantities above 1,000,000 pounds, the values given above will be extrapolated by means of the formulas: for IBD/PTRD:  $D=8W^{1/3}$ ; For aboveground magazine/ILD:  $D=5W^{1/3}$

<sup>4</sup> See paragraph's 8-2c & 8-2d for storage of limited quantities of items in this class without regard to QD and compatibility.

<sup>5</sup> The same distances are used for IBD and PTRD.

<sup>6</sup> The same distances are used for aboveground magazines and ILD.

<sup>7</sup> This column provides magazine distances between aboveground magazines. Other distances are as follows:

<sup>8</sup> Between earth-covered magazines: Earth-covered magazines of any size, of either 7-bar, 3-bar, or undefined construction, and mutually sited on the basis of at least 100 lb of HD 1.1 may be used to physical capacity.

<sup>9</sup> From the earth-covered magazines containing HD 1.3 to an aboveground magazine: Aboveground magazine distance separation is required.

<sup>10</sup> From an aboveground magazine containing HD 1.3 to an earth-covered magazine: A 50 ft minimum separation is required. If this minimum distance is met, the aboveground magazine may be loaded to physical capacity.

### 8-22. Moderate fire producing

In addition to fragments and firebrands, some ammunition and explosives are only mass-fire producing such as HD 1.4 and HD 1.6.

*a.* HD 1.4 items present a moderate fire hazard with no blast hazard and virtually no fragmentation hazard. QD in table 8-25 is based on fire hazard clearance.

*b.* Articles classified as 1.4S based on testing (as opposed to analogy) may be considered as inert for storage purposes and can be stored in any general purpose warehouse which provides adequate security. Questions about whether a given 1.4S item was classified by test or analogy shall be directed to USATCES.

### 8-23. Extremely insensitive ammunition and explosives

HD 1.6 affects are similar to those produced by HD 1.3. Quantity-distance separations for HD 1.6 ammunition will be based on the storage location and configuration. This information is detailed in table 8-26. A maximum of 500,000 pounds NEW will be permitted at any one location. Any special storage configuration and siting approved for HD 1.1 ammunition or explosives may be used to store like explosive weights of HD 1.6.

**Table 8–23  
Mass Fire Producing - HD 1.4 Ammunition and Explosives**

NEW (pounds)	Inhabited building distance (ft)	Public traffic route distance (ft)	ILD (ft) <sup>1</sup>	Magazine Distance (ft) <sup>1</sup>	
				Aboveground <sup>2</sup>	Earth-covered
For quantities up to and equal to 3000 pounds <sup>3, 4</sup>	75	75	50	50	0 from Sides & Rear; use Aboveground Magazine distance from front
For quantities larger than 3000 pounds (no upper limit specifically required for safety reasons)	100	100	50 (100 if combustible construction <sup>5</sup> )	50 (100 if combustible construction <sup>5</sup> )	

Notes:

<sup>1</sup> Magazines storing only HD 1.4 ammunition and explosives may be located at these magazine or ILD from all other magazines or operating buildings regardless of the hazard division or quantity of explosives authorized in those adjacent structures. Because the HD 1.4 ammunition and explosives may be destroyed as the result of a mishap involving the assets in those adjacent structures, application of this provision must be accepted by their Command on a case-by-case basis with consideration given to the value of HD 1.4 assets at risk.

<sup>2</sup> HD 1.4 ammunition and explosives may be stored in a general supplies warehouse area rather than in an explosives storage area. When storing in a general supplies warehouse area, any weatherproof warehouse structure may serve as a HD 1.4 magazine. Such a structure shall be separated from all other warehouses by aboveground magazine distance.

<sup>3</sup> For reasons of operational necessity, limited quantities of HD 1.4 ammunition and explosives, such as small arms ammunition and riot control munitions, may be stored without regard to QD within facilities such as hangars, arms rooms, and operating buildings. Alternatively, operationally necessary HD 1.4 ammunition and explosives may be stored in small magazines external to those facilities without regard to QD.

<sup>4</sup> See table 8–3 for the applicability of HD 1.4 quantity-distance criteria and the determination of NEW when HD 1.4 and other hazard division ammunition and explosives are located in the same site.

<sup>5</sup> Wood frame structures are an example of combustible construction. Concrete, masonry, and metal structures are examples of noncombustible construction.

**Table 8–24  
QD distances for HD 1.6 ammunition**

NEW (lbs)	IBD and PTRD <sup>3,4,5</sup> (feet)	Above-ground IMD or ILD <sup>1,3,4,5</sup> (feet)	NEW (lbs)	IBD and PTRD <sup>3,4,5</sup> (feet)	Above-ground IMD or ILD <sup>1,3,4,5</sup> (feet)
100 <sup>2</sup>	37	23	75,000	337	211
200	47	29	80,000	345	215
300	54	33	85,000	352	220
400	59	37	90,000	359	224
500	64	40	95,000	365	228
600	67	42	100,000	371	232
700	71	44	110,000	383	240
800	74	46	120,000	395	247
900	77	48	125,000	400	250
1,000	80	50	130,000	405	253
2,000	101	63	140,000	415	260
3,000	115	72	150,000	425	266
4,000	127	79	160,000	434	271
5,000	137	86	170,000	443	277
6,000	145	91	175,000	447	280
7,000	153	96	180,000	452	282
8,000	160	100	190,000	460	287
9,000	166	104	200,000	468	292

**Table 8-24**  
**QD distances for HD 1.6 ammunition—Continued**

10,000	172	108		225,000	487	304
15,000	197	123		250,000	504	315
20,000	217	136		275,000	520	325
25,000	234	146		300,000	536	334
30,000	249	155		325,000	550	344
35,000	262	164		350,000	564	352
40,000	274	171		375,000	577	361
45,000	285	178		400,000	589	368
50,000	295	184		425,000	601	376
55,000	304	190		450,000	613	383
60,000	313	196		475,000	624	390
65,000	322	201		500,000	635	397
70,000	330	206				

Notes:

<sup>1</sup> The same distances are used for aboveground IMDs and ILD. Earth-covered magazines may be used to their physical capacity for this division, provided they comply with the construction and siting requirements of chapters 4 and 8 for HD 1.1.

<sup>2</sup> For quantities less than 100 lbs, the required distances are those specified for 100 lbs. The use of lesser distances may be approved when supported by test data and/or analysis.

<sup>3</sup> Interpolation is permitted. For IBD and PTRD, use  $D=8W^{1/3}$ . For aboveground IMD and ILD, use  $D=5W^{1/3}$ .

<sup>4</sup> For IBD and PTRD, a minimum distance of K40 applies or fragment distance, whichever is greater. Distances will be based on a single round of HD 1.6 ammunition. For aboveground IMD and ILD, a minimum distance of K18 applies, based on a single round of HD 1.6 ammunition.

<sup>5</sup> For HD 1.6 items packed in nonflammable pallets or packing stored in earth-covered steel or concrete arch magazines, the following QD criteria apply, unless table 8-27 permits a lesser distance; IBD and PTRD - 100 feet; aboveground IMD and ILD - 50 feet; earth-covered IMD - no specified requirements.

### 8-24. Propulsive units

It is impractical to specify QD separations allowing for the designed flight range of propulsive units (rockets, missile motors, and catapults) that properly belong in HD 1.1, HD 1.2, or HD 1.3. Therefore, maximum designed flight ranges for units in a propulsive state will be disregarded.

### 8-25. The same Multiple operations in single building

In many operations, not only HD 1.1 but also HD 1.2, HD 1.3, and HD 1.4 are found in the various bays of an operating building. The following rules apply for QD determinations in these situations:

a. If any bay containing HD 1.1 has a quantity greater than the limit of its walls, determine the distance using the total quantity of all HD 1.1, HD 1.2, and HD 1.3 materials in the operating building. Consider the total quantity first as HD 1.1, next as HD 1.2, and finally as HD 1.3. The required distance is the greatest of the three.

b. Consider each bay containing HD 1.1 as a separate potential explosion site and determine the HD 1.1 distance required from each of these bays.

c. If no bay containing HD 1.1 exceeds its limits, proceed as follows:

(1) Total all HD 1.3 in the building and determine the HD 1.3 distance.

(2) Total all HD 1.2 in the building and determine the HD 1.2 distance per the appropriate HD 1.2 table (tables 8-20, 8-21, 8-22, and 8-23).

d. The greatest distance as computed by (1) through (3) above will govern.

### 8-26. Public traffic routes

a. For public traffic routes (PTRs), the minimum fragment and debris distance for HD 1.1 ammunition and explosives shall be based on the traffic density considered at three levels:

- (1) high traffic density,
- (2) medium traffic density,
- (3) low traffic density.

b. The traffic density shall be averaged over a normal (non-holiday) week in terms of number of passengers during a 24-hour period. Minimum fragment distance reductions based on sparsely populated locations addressed in paragraph 8-26g and figure 8-4, do not apply to PTRs.

Note. Note: In applying criteria other than the default values given below (which are based on car (and rail) speed of 50 mile/hour

(80 km/hour), and a ship speed of 10 mile/hour (16 km/hour)), considerations such as the following shall be taken into account to establish acceptable exposure: speed of vehicles, number of passengers per vehicle, protection afforded by the vehicle, variation in daily traffic levels in relation to explosives activities, and seasonal traffic trends. The default value of two passengers per car may be used to estimate traffic density.

c. If routes have 10,000 or more car and/or rail passengers per day, or 2,000 or more ship passengers per day, then inhabited building distance criteria found in table 8–8 apply.

d. If routes have 400 or more, but less than 10,000 car and/or rail passengers per day, or 80 or more, but less than 2,000 ship passengers per day, then 60 percent of the specified minimum fragment distance for inhabited building distance applies. Medium traffic density criteria for minimum fragment distance apply, as a minimum, to recreational activity that is extensive and occurs on a regular basis.

e. If routes have less than 400 cars and/or rail passengers per day, or less than 80 ship passengers per day, then no minimum fragment distance is required. Minimum distance shall be based on blast criteria (K24/K30) only.

f. For other exposures that are permitted at PTRD, fragment and debris distance minima for HD 1.1 ammunition and explosives shall be at least 60 percent of the specified minimum fragment distance for inhabited building distance.

g. For sparsely populated locations (for example, those populous locations where the personnel exposure is no greater than addressed below), the minimum 1,250 ft (380 m) fragment distance may be reduced to 900 ft (270 m) if certain specific conditions exist as follows (see figure 8–4):

(1) No more than 25 persons are located in any sector bounded by the sides of a 45-degree angle, with the vertex at the potential explosion site, and the 900 ft (270 m) and 1,250 ft (380 m) arcs from the potential explosion site.

(2) The NEW of the potential explosion site does not exceed 11,400 lbs (5,170 kg).

### **8–27. Transportation mode change locations**

Movement and transfer of ammunition and explosives must comply with national, international, and host country-specific transportation regulations. QD criteria apply to all transfer operations involving ammunition and explosives.

### **8–28. Remote operations (see glossary)**

a. *Accidental ignition or initiation of explosives at remotely controlled and/or shielded operations.*

(1) When the risk associated with the accidental explosion due to overpressures, hazardous fragments, or an accidental flash fire is greater than a de minimis risk (see DA Pam 385–30), personnel shall be protected from potential blast overpressures, hazardous fragments, thermal effects and attendant respiratory and circulatory hazards. During the determination of the risks, the reactivity, sensitivity, ignition stimuli and likelihood of ignition shall be considered when developing the probability. Fragmentation distances, inhalation of hot vapors, combustion products overpressures, thermal flux, effects of fire, protective capabilities of shields, clothing, and fire protection systems; survivability of the structures shall be considered when determining the severity.

(2) When required by paragraph 8–28a(1), above, protection for all personnel must be capable of limiting incident blast overpressure to 2.3 psi, fragments to energies of less than 58 ft-lb, and thermal fluxes to 0.3 calories per square centimeter per second. These protection levels shall be certified through analysis for cases where personnel are exposed at distances less than K24 or for situations where personnel exposure criteria are obviously exceeded. Shields complying with MIL–STD–398 are acceptable protection.

(3) Personnel hazards from broken glass can be minimized by building orientation and/or keeping the number of exposed glass panels and panel size to a minimum. When window panels are necessary and risk assessment determines a glass hazard will be present, blast resistant windows must be used. The framing and/or sash of such panels must be strong enough to retain the panel in the structure.

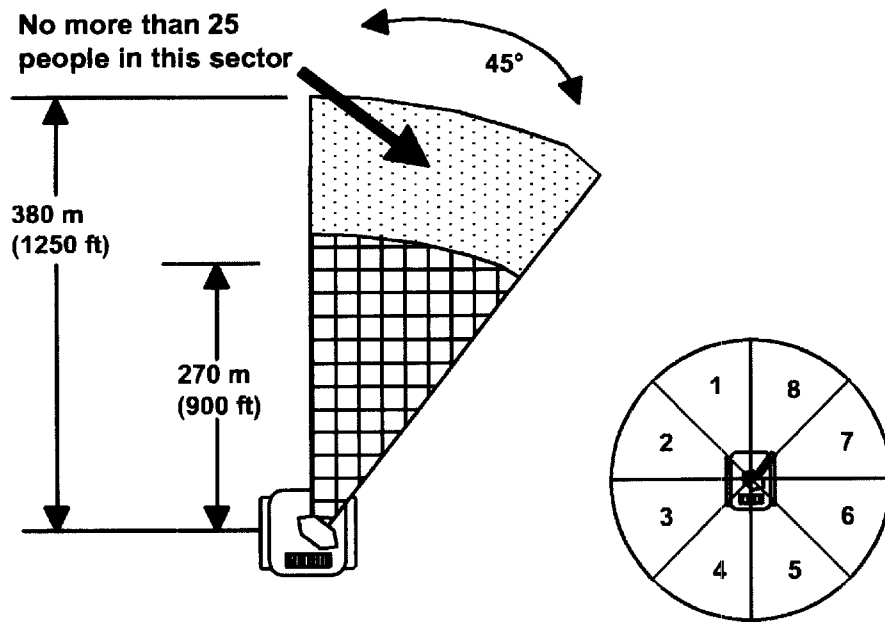

Figure 8-6. Example of sparsely populated locations

*b. Intentional ignition or initiation of explosives.*

(1) At operations where intentional ignition or initiation of explosives is conducted (such as function, proof, lot acceptance testing, and so forth), and where remote operation and/or shielding is required as determined on a case-by-case basis by their Command, protection for all personnel will meet the requirements of paragraph 8-28a(1), above, and must also be capable of limiting overpressure levels in personnel-occupied areas to satisfy MIL-STD-1474C, containing all fragments, and limiting thermal flux as expressed in table 8-27. Shields complying with MIL-STD-398 are acceptable protection.

(2) To determine overpressure protection requirements in accordance with MIL-STD-1474C, use table 8-28 through 8-30 and figure 8-5. They provide separation distances and hearing protection requirements to protect against both blast injury to the body and hearing loss. There are three methods for using the tables and figure, depending on what type of equipment is available to measure sound (see table 8-31).

(3) Personnel hazards from broken glass can be minimized by building orientation and/or keeping the number of exposed glass panels and panel size to a minimum. When window panels are necessary and risk assessment determines a glass hazard will be present, blast resistant windows must be used. The framing and/or sash of such panels must be strong enough to retain the panel in the structure.

*c. Distribution lines.* These are normally lines solely supplying multiple garrison or installation locations. Distribution lines, the poles or towers supporting them, and electrical substations directly connected to distribution lines will be separated from PESs by PTRD, based on blast only. (Use formulas contained in notes to table 8-8.

*d. Service lines.* Service lines are those lines supplying individual garrison or installation locations. When a service line provides power to an explosives facility, the line must be run underground for the last 50 feet to the facility. Service lines serving a combustible facility or an open potential explosion site may be no closer than the distance between the supporting poles or towers. If an effective means is provided to ensure that energized lines, upon breaking, cannot come into contact with the combustible facility or an open potential explosion site or its appurtenances, then they may be closer than the distance between the poles. Examples of effective means include messenger lines, cable trays, and ground fault circuit interrupters. Before implementing any of these means, a safety submission must be approved per chapter 4.

**Table 8-25**  
**Thermal flux calculations**

$Q=0.62t^{-0.7423}$	<b>Where:</b>
	"Q" is the calories/square centimeter/second
	"t" is the time in seconds

Notes:

<sup>1</sup> Shields complying with MIL-STD-398 are acceptable protection.

**Table 8-26**  
**Impulse noise protection decision table**

Type of equipment available	Applicable tables and figures
No equipment available.	Use table 8-29 and then table 8-31.
Equipment (such as a sound meter) is available to measure peak noise pressure. Peak noise pressure is expressed in decibels (db) but may be measured in any unit (psi, Pascals, and so forth) and converted to db (see MIL-STD-1474C).	Use table 8-30 then figure 8-5, then table 8-31.
Equipment is available to measure both peak noise pressure and the B-duration of the pressure.	Use figure 8-5 and then table 8-31.

Notes:

<sup>1</sup> Of the three methods above, the last method is best because it is the most precise and least conservative.

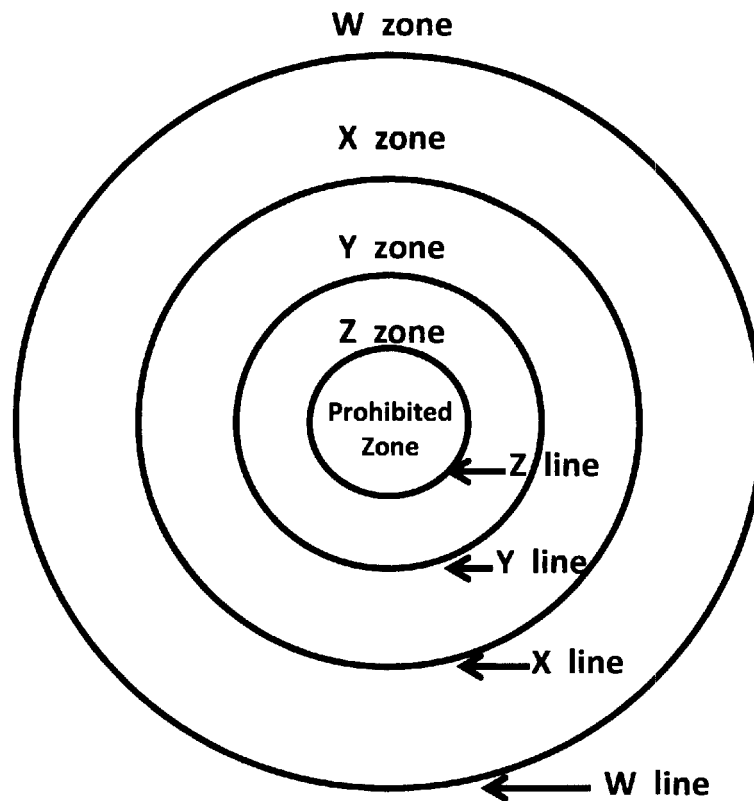

Figure 8-7. Impulse noise zones from intentional detonations

**Table 8–27**  
**Impulse noise zones measured in feet from intentional detonations**

<b>NEW</b>	<b>Prohibited zone</b>	<b>Z zone</b>	<b>Y zone</b>	<b>X zone</b>	<b>W zone</b>
1 oz	0	14	25	42	230
2 oz	0	18	31	53	290
3 oz	0	20	35	61	332
4 oz	0	22	39	67	365
5 oz	0	24	42	72	394
6 oz	0	25	45	76	418
7 oz	0	27	47	80	440
8 oz	0	28	49	84	460
9 oz	0	29	51	88	479
10 oz	0	30	53	91	496
11 oz	0	31	55	94	512
12 oz	0	32	56	96	527
13 oz	0	33	58	99	541
14 oz	0	33	59	101	555
15 oz	0	34	61	104	568
1 lb	0	35	62	106	580
2 lb	0	44	78	134	731
3 lb	0	50	89	153	837
4 lb	0	56	98	168	921
5 lb	0	60	106	181	992
6 lb	0	64	113	193	1,054
7 lb	0	67	119	203	1,110
8 lb	0	70	124	212	1,160
9 lb	0	73	129	220	1,206
10 lb	0	75	134	228	1,250
15 lb	0	89	153	243	1,430
20 lb	0	95	168	256	1,570
25 lb	0	102	181	267	1,696
30 lb	0	109	193	278	1,802
35 lb	0	114	203	288	1,897
40 lb	0	120	212	329	1,984
45 lb	0	124	221	363	2,063
50 lb	0	129	228	391	2,137
60 lb	0	137	243	415	2,271
70 lb	0	144	256	437	2,390
80 lb	0	151	267	457	2,499
90 lb	0	157	278	475	2,599
100 lb	0	162	288	492	2,692
150 lb	0	186	329	523	3,082
200 lb	0	205	363	551	3,392

**Table 8–27**  
**Impulse noise zones measured in feet from intentional detonations—Continued**

250 lb	0	220	391	576	3,654
300 lb	0	234	415	599	3,883
350 lb	0	247	437	620	4,087
400 lb	0	258	457	781	4,273
450 lb	0	268	475	894	4,445
500 lb	0	278	492	984	4,603
600 lb	0	295	523	1,060	4,892
700 lb	0	311	551	1,117	5,150
800 lb	0	325	572	1,186	5,384
900 lb	0	338	599	1,240	5,600
1,000 lb	0	350	620	1,290	5,800
2,000 lb	0	441	781	1,336	7,308
3,000 lb	0	505	894	1,529	8,365
4,000 lb	0	556	984	1,683	9,207
5,000 lb	0	598	1,060	1,813	9,918
6,000 lb	0	639	1,117	1,926	10,539
7,000 lb	0	670	1,186	2,028	11,095
8,000 lb	0	700	1,240	2,120	11,600
9,000 lb	0	728	1,290	2,205	12,064
10,000 lb	0	754	1,336	2,284	12,496

Notes:

<sup>1</sup> This table provides impulse noise zones for use with table 8–30.

<sup>2</sup> Use this table only if unable to measure the actual noise pressure (in db) from the intentional detonation. This table is very conservative. It does not consider the effects of terrain, earth cover, buildings, trees, and so forth in reducing noise and overpressure. This table also assumes a “worst case” impulse noise B-duration, the effect of which is to further increase required distances. For this reason, actual measurement of noise pressure is preferred.

<sup>3</sup> To read the table, using a NEW of 1 oz as an example, assume the Prohibited Zone is from 0 ft up to (but not including) 14 ft. Unless protected from blast, personnel are not allowed here due to possible non-auditory injury. The Z zone is from 14 ft up to (but not including) 25 ft. The Y zone is from 25 ft up to (but not including) 42 ft. The X zone is from 42 ft up to (but not including) 230 ft. The W zone is from 230 ft and beyond. After reading this table, go to table 8–32 to determine protection.

**Table 8–28**  
**Impulse noise B-duration (estimated for various NEWs and distances) (See notes 1 thru 5 below)**

NEW	Distance (feet)	B-duration (msec)	Distance (feet)	B-duration (msec)	Distance (feet)	B-duration (msec)	Distance (feet)	B-duration (msec)
1 oz	4	3	8	4	12	4	16	4
1 oz	20	5	24	5	28	5	32	5
1 oz	36	5	40	6	44	6		
2 oz	5	4	10	5	15	5	20	6
2 oz	25	6	30	6	35	6	40	7
2 oz	45	7	50	7	55	7		
3 oz	6	4	11	5	17	6	23	6
3 oz	29	7	34	7	40	7	46	8
3 oz	52	8	57	8	63	8		
4 oz	6	4	13	6	19	6	25	7
4 oz	31	7	38	8	44	8	50	8
4 oz	57	9	63	9	69	9		



**Table 8-28**  
**Impulse noise B-duration (estimated for various NEWs and distances) (See notes 1 thru 5 below)—Continued**

5 oz	7	5	14	6	20	7	27	8
5 oz	34	8	41	8	48	9	54	9
5 oz	61	9	68	10	75	10		
6 oz	7	5	14	6	22	7	29	8
6 oz	36	9	43	9	50	9	58	10
6 oz	65	10	72	10	79	10		
7 oz	8	5	15	7	23	8	30	8
7 oz	38	9	46	9	53	10	61	10
7 oz	68	10	76	11	84	11		
8 oz	8	6	16	7	24	8	32	9
8 oz	40	9	48	10	56	10	63	11
8 oz	71	11	79	11	87	12		
9 oz	8	6	17	7	25	8	33	9
9 oz	41	10	50	10	58	11	66	11
9 oz	74	11	83	12	91	12		
10 oz	9	6	17	8	26	9	34	9
10 oz	43	10	51	11	60	11	68	11
10 oz	77	12	86	12	94	12		
11 oz	9	6	18	8	26	9	35	10
11 oz	44	10	53	11	62	11	71	12
11 oz	79	12	88	13	97	13		
12 oz	9	6	18	8	27	9	36	10
12 oz	45	11	55	11	64	12	73	12
12 oz	82	13	91	13	100	13		
13 oz	9	7	19	8	28	10	37	10
13 oz	47	11	56	12	65	123	75	12
13 oz	84	13	93	13	103	14		
14 oz	10	7	19	9	29	10	38	11
14 oz	48	11	57	12	67	12	77	13
14 oz	86	13	96	14	105	14		
15 oz	10	7	20	9	29	10	39	11
15 oz	49	12	59	12	69	13	78	13
15 oz	88	13	98	14	108	14		
1 lb	10	7	20	9	30	10	40	11
1 lb	50	12	60	12	70	13	80	13
1 lb	90	14	100	14	110	15		
2 lb	13	9	25	11	38	13	50	14
2 lb	63	15	76	16	88	16	101	17
2 lb	113	17	126	18	138	18		
3 lb	14	10	29	13	43	15	58	16
3 lb	72	17	87	18	101	19	115	19
3 lb	130	20	144	20	159	21		
4 lb	16	11	32	14	48	16	63	18

**Table 8–28**  
**Impulse noise B-duration (estimated for various NEWs and distances) (See notes 1 thru 5 below)—Continued**

4 lb	79	19	95	20	111	21	127	21
4 lb	143	22	159	23	175	23		
5 lb	17	12	34	15	51	17	68	19
5 lb	85	20	103	21	120	22	137	23
5 lb	154	24	171	24	188	25		
6 lb	18	13	36	16	55	19	73	20
6 lb	91	21	109	23	127	24	145	24
6 lb	164	25	192	26	200	26		
7 lb	19	13	38	17	57	20	77	21
7 lb	96	23	115	24	134	25	153	26
7 lb	172	26	191	27	210	28		
8 lb	20	14	40	18	60	20	80	22
8 lb	100	24	120	25	140	26	160	27
8 lb	180	28	200	28	220	29		
9 lb	21	15	42	19	62	21	83	23
9 lb	104	25	125	26	146	27	166	28
9 lb	187	29	208	29	229	30		
10 lb	22	15	43	19	65	22	86	24
10 lb	108	25	129	27	151	28	172	29
10 lb	194	30	215	31	237	31		
15 lb	25	17	49	22	74	25	99	27
15 lb	123	29	148	31	173	32	197	33
15 lb	222	34	247	271	36			
20 lb	27	19	54	24	81	28	109	30
20 lb	136	32	163	34	190	35	217	36
20 lb	244	37	271	38	299	39		
25 lb	29	21	58	26	88	30	117	32
25 lb	146	35	175	46	205	38	234	39
25 lb	263	40	292	41	322	43		
30 lb	31	22	62	28	93	32	124	34
30 lb	155	37	186	39	217	40	249	42
30 lb	280	43	311	44	342	45		
35 lb	33	23	65	29	98	33	131	36
35 lb	164	39	196	41	229	42	62	44
35 lb	294	45	327	46	360	48		
40 lb	34	24	68	31	103	35	137	38
40 lb	171	40	205	43	239	44	274	46
40 lb	308	47	342	48	376	50		
45 lb	36	25	71	32	107	36	142	39
45 lb	178	42	213	44	249	46	285	48
45 lb	320	49	356	50	391	52		
50 lb	37	26	74	33	111	38	147	41
50 lb	184	44	221	46	258	48	295	49

**Table 8-28**  
**Impulse noise B-duration (estimated for various NEWs and distances) (See notes 1 thru 5 below)—Continued**

50 lb	332	51	368	52	405	54		
60 lb	39	28	78	35	117	40	157	43
60 lb	196	46	235	49	274	51	313	52
60 lb	352	54	391	55	431	57		
70 lb	41	29	82	37	124	42	165	46
70 lb	206	49	247	51	288	53	330	55
70 lb	371	57	412	58	453	60		
80 lb	43	30	86	39	129	44	172	48
80 lb	215	51	258	54	302	56	345	58
80 lb	388	59	431	61	474	63		
90 lb	45	32	90	40	134	46	179	50
90 lb	224	53	269	56	314	58	358	60
90 lb	403	62	448	64	493	65		
100 lb	46	33	93	42	139	47	186	51
100 lb	232	55	278	58	325	60	371	62
100 lb	418	64	464	66	510	68		
150 lb	53	37	106	48	159	54	212	59
150 lb	266	63	319	66	572	69	425	71
150 lb	478	73	531	75	584	77		
200 lb	58	41	117	53	175	60	234	65
200 lb	292	69	351	73	409	76	468	78
200 lb	526	81	585	83	643	85		
250 lb	63	44	126	57	189	64	252	70
250 lb	315	74	378	78	441	82	504	84
250 lb	567	87	630	89	693	92		
300 lb	67	47	134	60	201	68	268	74
300 lb	335	79	402	83	469	87	535	90
300 lb	602	92	669	95	736	97		
350 lb	70	50	141	63	211	72	282	78
350 lb	352	82	423	88	493	91	564	94
350 lb	634	97	705	100	775	103		
400 lb	74	52	147	66	221	75	295	82
400 lb	268	87	442	92	516	95	589	99
400 lb	663	102	737	104	810	107		
450 lb	77	54	153	69	230	78	306	85
450 lb	383	91	460	95	536	99	613	103
450 lb	690	106	766	109	843	111		
500 lb	79	56	159	71	238	81	317	88
500 lb	397	94	476	99	555	103	635	106
500 lb	714	109	794	113	873	115		
600 lb	84	59	169	76	253	86	337	94
600 lb	422	100	506	105	590	109	75	113
600 lb	759	116	843	120	928	123		

**Table 8–28**  
**Impulse noise B-duration (estimated for various NEWs and distances) (See notes 1 thru 5 below)—Continued**

700 lb	89	63	178	80	266	91	355	98
700 lb	444	105	533	110	621	115	710	119
700 lb	799	122	888	126	976	129		
800 lb	93	65	186	84	278	95	371	103
800 lb	464	110	557	115	650	120	742	124
800 lb	835	128	928	132	1,021	135		
900 lb	97	68	193	87	290	98	386	107
900 lb	438	114	579	120	676	123	772	129
900 lb	869	133	965	137	1,062	140		
1000 lb	100	70	200	90	300	102	400	111
1000 lb	500	118	600	124	700	130	800	134
1000 lb	900	138	1,000	142	1,100	145		
2000 lb	126	89	252	113	378	128	504	140
2000 lb	630	149	756	157	882	163	1,008	169
2000 lb	1,134	174	1,260	179	1,386	183		
3000 lb	144	102	288	130	433	147	577	160
3000 lb	721	171	865	179	1,009	187	1,153	93
3000 lb	1,298	199	1,442	204	1,586	210		
4000 lb	159	112	317	143	476	162	635	176
4000 lb	793	188	952	197	1,111	206	1,270	213
4000 lb	1,428	219	1,587	225	1,746	231		
5000 lb	171	120	342	154	513	174	684	190
5000 lb	855	202	1,026	213	1,197	221	1,368	229
5000 lb	1,539	236	1,709	242	1,880	249		
6000 lb	182	128	363	164	545	184	727	201
6000 lb	908	215	1,090	226	1,272	235	1,453	243
6000 lb	1,635	250	1,817	258	1,998	264		
7000 lb	191	135	382	172	574	195	765	212
7000 lb	956	226	1,147	238	1,339	248	1,530	256
7000 lb	1,721	264	1,912	271	2,104	278		
8000 lb	200	141	400	180	600	204	800	222
8000 lb	1,000	236	1,200	249	1,400	259	1,600	268
8000 lb	1,799	276	1,999	283	2,199	291		
9000 lb	208	146	416	187	624	212	832	231
9000 lb	1,040	246	1,245	259	1,456	269	1,664	279
9000 lb	1,872	287	2,079	295	2,287	303		
10000 lb	215	152	431	194	646	220	862	239
10000 lb	1,077	255	1,292	268	1,508	279	1,723	288

**Table 8–28**  
**Impulse noise B-duration (estimated for various NEWs and distances) (See notes 1 thru 5 below)—Continued**

10000 lb	1,938	297	2,154	305	2,369	313		
----------	-------	-----	-------	-----	-------	-----	--	--

Notes:

<sup>1</sup> Use table 8–29 to measure the peak impulse noise in decibels (a sound meter is all that is required). After measuring the peak impulse noise, estimate the impulse noise B-duration using this table. Then go to figure 8–5 and find the impulse noise zone. From there, go to table 25 to determine the protection required.

<sup>2</sup> To read table 8–29, if the NEW is 1 oz and personnel are 4 feet away, what is the B-duration? Answer: The B-duration is 3 milliseconds (msec). If the NEW is 1 oz and personnel are 17 feet away, what is the B-duration? Answer: 17 feet lies between 16 feet (4 msec) and 20 feet (5 msec). To be conservative, choose the larger value: 5 msec. Linear interpolations between table values are not permitted. The answer, then, is 5 msec.

<sup>3</sup> “B-duration” is defined as the total time in milliseconds for the noise pressure to rise to a peak and then fall back. Any significant fluctuations after the initial rise and fall are also included in B-duration. To the human ear, all one hears is a single sound; specialized equipment is required to measure the sound wave to determine its durations. Procedures to calculate impulse noise s-duration from measured sound waves are in MIL–STD–1474.

<sup>4</sup> It is best to determine B-duration from measured sound waves in accordance with MIL–STD–1474 instead of estimating it using this table. This table conservatively estimates B-duration to account for unknown conditions, such as reflecting surfaces, which can lengthen B duration.

<sup>5</sup> The B-duration values in this table were derived by computing the duration of the positive portion of the overpressure wave per TM 5–1300. This duration was then tripled to conservatively account for follow-on fluctuations caused by reflections from walls, roofs, and so forth.

**Table 8–29**  
**Impulse noise zones and required protections with maximum permissible number of detonations per day**

Impulse noise zone	No protection	Either ear plugs or ear muffs	Both ear plugs and ear muffs
<b>W zone</b> <sup>1</sup>	Unlimited exposures	Unlimited exposures	Unlimited exposures
<b>X zone</b>	0	2,000	40,000
<b>Y zone</b>	0	100	2,000
<b>Z zone</b>	0	5	100
<b>Prohibited zone</b> <sup>2</sup>	No personnel allowed	No personnel allowed	No personnel allowed

Notes:

<sup>1</sup> The W zone is the zone where noise levels are 140 decibels (db) or lower. One hundred forty decibels is the maximum impulse noise level allowed by MIL–STD–1474 for personnel not wearing hearing protection. It should be noted that 140 db presents a high risk of complaints from the public. One hundred fifteen decibels is the generally accepted threshold for noise complaints.

<sup>2</sup> Unless protected from blast so that pressure levels are reduced to the W, X, Y, or Z zones, no personnel are allowed in the prohibited zone because of possible non-auditory injury.

**8–29. Range operations**

*a. Ranges used to detonate ammunition for demilitarization, demonstration, and explosives ordnance disposal.* The minimum separation distances between ranges (where explosives demolitions, demonstrations, and EOD explosives operations are conducted) and nonessential personnel are determined by application of the criteria given below. If the minimum separation distance requirements for previously approved DDESB site plans or those prescribed in this section cannot be met, then personnel shall be provided with protection as specified in paragraph 8–28a & b, above.

*b. Essential personnel.* Competent authorities on site determine the minimum separation distance for essential range personnel. These authorities will also determine who is essential.

*c. Nonessential personnel.* This paragraph provides the primary criteria for protection of nonessential personnel. If these criteria cannot be met, then the criteria in paragraph 8–28a & b may be used as an alternate.

*d. Control sites.* Control sites for ammunition and explosives destruction, demonstration, and EOD operations must be at ILD from other PESs based on the potential explosion site NEW.

*e. Ballistics uncertainties.* Due to ballistic uncertainties for impact locations of various weapons and delivery systems, where demonstrations involve live fire exercises, range safety considerations shall be determined on a case-by-case basis by competent test authorities.

*f. Protective structures.* Protective structures for personnel or measures taken to suppress blast and/or fragment effects, at disposals and demonstrations, may be used to reduce the required withdrawal distance.

*g. Use the safe separation distances derived by one of the methods below.* The greater of the distances given in table 8–32 for the appropriate diameter or calculated using Distance (Feet)=328 W<sup>1/3</sup>, where the distance will never be less than 1,250 feet for non-fragmenting explosive materials.

**Table 8–30**

**Default maximum case maximum fragment distances versus diameter for international detonations (see notes 1 - 6 below)**

Diameter (in) (mm)	Maximum fragmentation distance <sup>1</sup>		
	Robust <sup>2</sup> (ft) (m)	Extremely heavy case <sup>3</sup> (ft) (m)	Non robust <sup>4</sup> (ft) (m)
0.1 2.45	100 30.5	178 54.2	131 40.0
0.2 5.08	136 41.4	285 86.9	248 75.6
0.3 7.62	214 65.1	376 114.6	349 106.4
0.4 10.16	290 88.5	458 139.5	439 133.7
0.5 12.70	365 111.3	533 162.4	519 158.4
0.6 15.24	438 133.5	603 183.9	593 180.9
0.7 17.78	509 155.1	670 204.3	661 201.7
0.8 20.32	578 176.1	734 223.8	725 221.0
0.9 22.86	645 196.6	796 242.5	784 239.1
1.0 25.40	711 216.5	855 260.5	840 256.1
1.5 38.10	1,016 309.4	1,127 343.5	1,079 328.9
2.0 50.80	1,290 392.8	1,371 418.0	1,270 387.3
2.5 63.50	1,539 468.7	1,597 486.7	1,430 436.2
3.0 76.20	1,769 538.6	1,808 551.1	1,568 478.2
3.5 88.90	1,983 603.5	2,009 612.2	1,688 514.9
4.0 101.60	2,182 664.2	2,200 670.6	1,795 547.6
4.5 101.60	2,369 721.1	2,384 726.7	1,892 576.9
5.0 127.00	2,546 774.9	2,562 780.9	1,979 603.5
5.5 139.70	2,713 825.8	2,734 833.3	2,058 627.7
6.0 152.40	2,872 874.2	2,901 884.2	2,131 650.0
6.5 165.10	3,024 920.3	3,064 933.9	2,198 670.5
7.0 177.80	3,169 964.4	3,223 982.3	2,261 689.5
7.5 190.5	3,307 1,006.6	3,378 1,029.6	2,319 707.3
8.0 203.20	3,440 1,047.1	3,530 1,075.9	2,373 723.8
8.5 215.90	3,568 1,086.0	3,679 1,121.3	2,424 739.3

**Table 8-30**  
**Default maximum case maximum fragment distances versus diameter for international detonations (see notes 1 - 6 below)—Continued**

9.0 228.60	3,691 1,123.4	3,825 1,165.9	2,472 753.9
9.5 241.30	3,810 1,159.5	3,969 1,209.7	2,517 767.6
10.0 254.00	3,924 1,194.4	4,110 1,252.8	2,559 780.6
10.5 266.70	4,035 1,228.0	4,249 1,295.2	2,599 792.9
11.0 279.40	4,142 1,260.6	4,386 1,336.9	2,637 804.5
11.5 292.10	4,246 1,292.2	4,521 1,378.1	2,674 815.5
12.0 304.80	4,347 1,322.8	4,654 1,418.6	2,708 826.0
12.5 317.50	4,444 1,352.5	4,786 1,458.7	2,741 836.0
13.0 330.20	4,539 1,381.3	4,916 1,498.2	2,772 845.5
13.5 342.90	4,631 1,409.4	5,044 1,537.3	2,802 854.6
14.0 355.60	4,721 1,436.7	5,170 1,575.9	2,830 863.3
14.5 368.30	4,808 1,463.2	5,296 1,614.1	2,857 871.6
15.0 381.00	4,893 1,489.1	5,419 1,651.8	2,883 879.6
16.0 406.40	5,057 1,538.9	5,663 1,762.2	2,933 894.5
18.0 457.20	5,362 1,631.5	6,137 1,870.5	3,020 921.1
20.0 508.00	5,640* 1,716.2*	6,594* 2,009.9*	3,095* 944.0*
22.0 558.80	5,896* 1,794.0*	7,037* 2,144.9*	3,160* 963.9*
24.0 609.60	6,133* 1,866.0*	7,467* 2,276*	3,217* 981.4*
26.0 660.40	6,353* 1,932.8*	7,886* 2,403.7*	3,268* 996.8*
28.0 711.20	6,558* 1,995.2*	8,295* 2,528.3*	3,312* 1,010.5*
30.0 762.00	6,750* 2,053.6*	8,695* 2,650.1*	3,352* 1,022.7*
35.0 889.00	7,182* 2,184.9*	9,659* 2,943.9*	3,435* 1,047.9*
40.0 1,016.00	7,557* 2,298.9*	10,580* 3,224.6*	3,499* 1,067.4*
45.0 1,143.00	7,887* 2,399.2*	11,465* 3,494.3*	3,549* 1,082.7*
50.0 1,270.00	8,180* 2,488.3*	12,319* 3,754.7*	3,588* 1,094.7*
55.0 1,397.00	8,443* 2,568.2*	13,146* 4,006.8*	3,619* 1,104.2*

**Table 8–30**  
**Default maximum case maximum fragment distances versus diameter for international detonations (see notes 1 - 6 below)—Continued**

60.0 1,524.00	8,680* 2,640.3*	13,950* 4,251.8*	3,644* 1,111.7*
*Extrapolated			

Notes:

<sup>1</sup> These calculated fragment throw distances are for individual items and do not apply to stacks. They also do not address “rogue” (non-case) fragments produced by sections of nose plugs, base plates, boat-tails, or lugs. Rogue fragments can travel to significantly greater distances (for example, greater than 10,000 ft [3,048 m]) than those shown. Care must be taken to properly orient the munition or take other measures to minimize rogue fragment hazards.

<sup>2</sup> Robust Munitions are defined in the glossary. a. Maximum Fragment Distance (MFD) in ft, Diameter (D) in inches;  $\ln$  is natural logarithm; b.  $MFD=711 * D(0.91-0.073*\ln(D))$ ; c.  $D=\exp [6.233 - \{128.804 - 13.699 * \ln (MFD)\}/1/2]$ ; d. MFD in m, diameter (D) in mm;  $\ln$  is natural logarithm; e.  $MFD=5.138 * D(1.382-0.073*(D))$ ; f.  $D=\exp [9.467 - \{112.531 - 13.699 * \ln (MFD)\}/1/2]$

<sup>3</sup> Extremely Heavy Case Munitions are defined in the glossary. a.  $MFD=854.8 * D(0.682)$ ; b.  $D=5.0243E-05 * MFD(1.4663)$ ; c. MFD in m, Diameter (D) in mm;  $\ln$  is natural logarithm; d.  $MFD=28.693 * D(0.682)$ ; e.  $D=(7.2862E-03) * MFD(1.4663)$ .

<sup>4</sup> Non-Robust Munitions are defined in the glossary: a. Maximum Fragment Distance (MFD) in ft, Diameter (D) in inches;  $\ln$  is natural logarithm; b.  $MFD=840 * D(0.645-0.07*\ln(D))$ ; c.  $D=\exp [4.607 - \{117.417 - 14.286 * \ln (MFD)\}/1/2]$ ; d. MFD in m, Diameter (D) in mm;  $\ln$  is natural logarithm; e.  $MFD=15.278 * D(1.098-0.07*\ln(D))$ ; f.  $D=\exp [7.842 - \{100.448 - 13.699 * \ln (MFD)\}/1/2]$ .

<sup>5</sup> Use of equations given in notes (2), (3), and (4) to determine other Diameter/MFD combinations is allowed.

<sup>6</sup> See paragraph 8–29i for ranges associated with multiple round detonations.

(1) A calculated or measured maximum fragment throw range (including the interaction effects for stacks of items or single items, whichever applies), with an appropriate safety factor of 1.25, may be used to replace the distances given in table 8–32.

(2) Table 8–33 presents calculated case fragment maximum throw ranges for selected item detonations. Those ranges were determined using the procedures given in HNC–ED–CS–S–98–1, “Methods for Predicting Primary Fragmentation Characteristics of Cased Explosives,” U.S. Army Corps of Engineers Engineering Support Center, Huntsville, AL, January 1998. Those calculated case fragment throw ranges are for individual items and do not apply to stacks of munitions.

(3) They also do not address “rogue” fragments produced by sections of nose plugs, base plates and/or lugs. “Rogue” fragments can travel to significantly greater distances (ranges greater than 10,000 feet) than those shown in table 8–33. Care must be taken either to properly orient the item or to take other efforts to minimize or eliminate this effect.

Note. Note: Items shall always be sited so that lugs and/or strong backs and nose and/or tail plate sections are oriented away from personnel locations.

*h. Detonations involving multiple rounds.* When detonations involve multiple rounds, the preferred approach is as follows:

- (1) Munitions shall be placed in a single layer with their sides touching such that their axis is horizontal;
- (2) The munitions shall be placed so that the nose of each munitions is pointing in the same direction;

**Table 8–31**  
**Maximum case fragment ranges for selected single item detonations (see notes 1 thru 3 below)**

Munitions	Maximum fragment throw range (case fragments) (feet)
20 mm projectile	320
25 mm projectile	760
37 mm projectile	980
40 mm projectile	1100
40 mm grenade	345
M229, 2.75" rocket	1375
M48, 75-mm projectile	1700
M1, 105-mm projectile	1940
MK 35, 5"/38 projectile	2205
MK 64, 5"/54 projectile	1800



**Table 8-31**  
**Maximum case fragment ranges for selected single item detonations (see notes 1 thru 3 below)—Continued**

M107, 155-mm projectile	2580
M437, 175-mm projectile	2705
M106, 8-in projectile	3290
MK 13 & MK 14, 16"/50 projectile	5640
M49A3, 60-mm mortar	1080
M374, 81-mm mortar	1235
M3A1, 4.2-in mortar	1620
M64A1 500-lb bomb	2500
MK 81, 250-lb bomb	2855
MK 82, 500-lb bomb	3180
MK 83, 1000-lb bomb	3290
MK 84, 2000-lb bomb	3880
BLU-109 bomb	4890

Notes:

<sup>1</sup> These calculated fragment throw ranges are for individual items and do not apply to detonations involving multiple rounds. See paragraph 8-29i for application to multiple round detonations.

<sup>2</sup> These ranges do not address "rogue" fragments produced by sections of nose plugs, base plates and/or lugs. Those non-case fragments can travel to significantly greater distances than those shown in this table (distances greater than 10,000 feet). Care must be taken to properly orient the item to minimize or eliminate this effect.

<sup>3</sup> Ranges shown are for case fragments. Shaped charge jets or slugs can go to significantly greater distances.

(3) Munitions shall be oriented so that lugs and/or strongbacks and nose and/or tail plate sections (rogue fragments) are facing away from areas to be protected;

(4) The consolidated shot shall be initiated in such a manner that detonation of all munitions is simultaneous.

(5) When these procedures are not followed but the orientation of the rogue fragments can be controlled, then the ranges given in table 8-32 and table 8-33 must be increased by 20 percent to account for interaction effects.

(6) When multiple rounds are arranged in stacks in which the orientation of individual items cannot be controlled, fragment ranges must be evaluated on a case-by-case basis.

(7) When detonations involve stacks of mixed munitions types, evaluate the ranges for each type separately using the procedures just presented and use the larger of the ranges that are obtained.

*i. Aboveground unburied detonations.* For aboveground (unburied) detonations, use tables 8-32, 8-33, 8-35, and 8-36 to determine blast and fragment or debris distance. Instead of the formula  $D=328W^{1/3}$ , the 0 foot column of table 8-34 may be used.

*j. Buried detonations.* For buried detonations, the distances in tables 8-32 and 8-33 may be reduced as follows:

(1) Use table 8-28 to determine reduced blast distance for buried detonations.

(2) Use the following procedure to determine reduced fragment or debris distance for buried detonations:

(a) For existing detonation operations for which approved local SOPs prescribe procedures which experience has shown adequate to contain fragments within the controlled access area, existing distances will be considered adequate.

(b) For new detonation operations such as those involving a greater quantity or different type of munitions, applicable on-site authorities may determine earth cover depth and safe separation distance by conducting thorough reconnaissance of adjoining lands during trials to observe debris and fragment throw ranges, and then adding 20 percent to the maximum observed throw range as an appropriate safety factor.

(3) In addition to burial, protective structures for nonessential personnel may also allow use of distances less than those required in tables 8-32 and 8-33. The protective structures must limit blast overpressure to occupants to no more than 0.065 psi, and must protect completely from all fragments and debris.

(4) Where demonstrations involve live fire (that is, cannon, rocket launchers, and so forth), competent local authorities will determine safe viewing range from the impact area using surface danger zone data found in range safety regulations. The distances in tables 8-26, 8-30, and 8-32 do not apply.

**Table 8–32**

**Required blast overpressure protection distance in feet for nonessential personnel at ranges used for detonating ammunition for demilitarization, demonstration, or explosives ordnance disposal**

NEW (lbs)	Burial depth in feet							
	0	1	2	3	4	5	10	15
1	328	79	16	16	16	16	16	16
5	561	261	104	41	28	28	28	28
10	707	398	191	92	44	35	35	35
20	890	464	326	182	102	57	45	45
30	1,019	599	368	260	157	94	51	51
40	1,122	650	439	329	208	131	56	56
50	1,208	721	501	349	255	165	60	60
100	1,522	984	737	553	414	326	76	76
150	1,743	1,171	911	708	550	428	105	87
200	1,918	1,322	1,052	837	665	529	151	96
250	2,066	1,450	1,172	948	727	620	198	103
300	2,196	1,562	1,279	1,047	858	702	234	110
350	2,312	1,663	1,375	1,137	941	778	288	116
400	2,417	1,755	1,463	1,220	1,018	849	332	121
450	2,514	1,839	1,545	1,297	1,089	915	375	134
500	2,603	1,918	1,620	1,369	1,157	977	417	154
1,000	3,280	2,515	2,200	1,924	1,683	1,472	754	360
1,500	3,755	2,936	2,612	2,324	2,067	1,839	1,025	556
2,000	4,133	3,273	2,943	2,646	2,380	2,140	1,258	739
2,500	4,452	3,558	3,224	2,921	2,647	2,398	1,465	894
3,000	4,731	3,808	3,471	3,163	2,883	2,627	1,652	1,039
4,000	5,207	4,236	3,893	3,578	3,289	3,023	1,983	1,301
5,000	5,609	4,598	4,251	3,931	3,635	3,362	2,273	1,537
6,000	5,960	4,915	4,566	4,241	3,940	3,660	2,533	1,752
7,000	6,274	5,199	4,847	4,520	4,214	3,929	2,769	1,952
8,000	6,560	5,457	5,104	4,773	4,464	4,175	2,988	2,138
9,000	6,823	5,695	5,340	5,007	4,695	4,402	3,191	2,313
10,000	7,067	5,916	5,560	5,225	4,910	4,614	3,382	2,479

Notes:

<sup>1</sup> This table provides distances for protection from blast overpressure only. Fragment distances are given in table 8–32 and 8–33 and may be reduced per paragraph 8–29i.

<sup>2</sup> The 0 foot column distances are for above ground or open pit detonations and are based on the formula:  $D=328W^{1/3}$ .

**8–30. Explosive ordnance disposal operations**

*a. Explosive ordnance disposal operational incidents.* The EOD operational incidents involving threat devices require the application of public withdrawal distances to all nonessential personnel as prescribed in paragraphs 8–29a and 8–29c, above.

*b. Explosive ordnance disposal operations and demonstrations.* The EOD operations and/or demonstrations conducted on ranges require minimum nonessential personnel separation distances as prescribed in table 8–6.

*c. Essential personnel at explosive ordnance disposal operations.* Essential personnel conducting EOD training operations, or operations involving demolition of ammunition and explosives, do not require minimum separation distances. Protection of these individuals shall be determined by competent on-site authorities.

*d. Explosive ordnance disposal proficiency ranges.* The EOD training ranges to maintain EOD proficiency are

limited to a maximum of 5 lb of demolition explosives (bare charges or items without a fragment hazard). The ranges are to be constructed and sited as follows:

(1) The destruction point must be at least 500 feet from all other facilities, such as those with IBD, PTRD, or ILD requirements.

(2) If the destruction point separation distance cannot satisfy the 500 feet requirement described above, then the separation distance may be reduced to 300 feet if the range is limited to 2.5 lb, or 200 feet if the range is limited to HD 1.25 lb of demolition explosives. Destruction points located with these reduced distances must be barricaded as follows:

(a) A barricade is to be constructed within 10 feet of the destruction point to control ejection of debris. It must be the equivalent of two sandbags thick and at least 6 feet high.

(b) The barricade must have two entrances opposing each other at 180 degrees separation. Each entrance must have a barricade equivalent to two sandbags thick and be long enough to effectively block all fragments and blast.

(c) If a training range is used for operations that will produce fragments above the level expected for normal EOD proficiency training (normally open shots), then the range must satisfy the requirements of paragraph 8–28f and 8–28g, above.

(d) The range distance may be reduced to 100 feet if the EOD training is done using explosively operated tool kits. In this case, the site must be barricaded as described above and only inert ammunition items used for training.

### **8–31. Demilitarization processing equipment and operations for expended .50-caliber and smaller cartridge casings**

a. A demilitarization operation for processing expended .50-caliber and smaller cartridge cases can be treated as a nonexplosive operation provided—

(1) Cartridge casings to be processed are screened prior to processing.

*Note.* (Screening is intended to ensure that only .50-caliber and smaller are processed, and to remove unused .50-caliber and smaller cartridges.)

(2) Only equipment approved by US Army Technical Center for Explosives Safety will be used for such operations. Equipment fielded under the Ammunition Peculiar Equipment program is automatically considered to have received approval from US Army Technical Center for Explosives Safety.

(3) Demilitarization processing equipment is operated within the manufacturer's specifications and restricted only to the processing of expended .50-caliber and smaller cartridge casings.

(4) Demilitarization processing equipment is inspected and maintained to ensure safe operation.

b. Installation or garrison commanders shall establish and implement procedures for:

(1) Screening and segregating the material to be processed.

(2) Operating, inspecting, and maintaining the demilitarization processing equipment to ensure safe operation.

(3) Evaluation of processed material.

(4) Explosives Safety Siting.

(a) Demilitarization processing operation locations meeting requirements of subparagraph (1) above, and located outside of IBD from all PESs, do not require submission of a site plan.

(b) Locations used for demilitarization processing operations that are located within IBD arcs shall require submission of a site plan and shall be sited at ILD, except from the potential explosion site to which it is integral.

### **8–32. Airfields, heliports, and seadromes**

a. This paragraph applies to airfields, heliports, and seadromes located within the United States, its territories, and its possessions used by the Army at which ammunition and explosives are under the control and custody of DOD military or civilian personnel. Chapter 9 applies where these requirements cannot be met in a foreign nation. The provisions to this paragraph do not apply to explosives items installed on aircraft or contained in survival and rescue kits such as flares, signals, egress systems components, squibs, and detonators for jettisoning external stores, engine-starter cartridges, fire extinguisher cartridges, destructors in electronic equipment, explosives components of emergency equipment, and other such items of materials necessary for safe flight operations.

b. Aircraft, parked in designated aircraft parking areas that meet airfield criteria, loaded with munitions, shown in paragraphs below, are exempt from quantity-distance requirements when evaluated as a potential explosion site—

(1) HD 1.2.2 - gun ammunition, 30 mm or less.

(2) HD 1.3 - Captive missiles or aircraft defensive flare/chaff.

(3) HD 1.4 - munitions.

c. Uploading and downloading of explosives will be conducted in explosives sited aircraft parking areas with the exception of munitions listed in paragraphs 8–31b(1) through 8–31b(3), above. These munitions can be uploaded and downloaded at the designated aircraft parking areas provided that the quantity of munitions involved in the operation is limited to a single aircraft load.

d. Measurement of separation distances. In applying table 8–35 and table 8–36 distances will be measured as follows:

(1) *Loaded aircraft to loaded aircraft.* Measure the shortest distance between explosives on one aircraft to explosives on the adjacent aircraft.

(2) *Ammunition and explosives location to taxiways and runways.* Measure from the nearest point of the ammunition and explosives location to the nearest point of the taxiway and to the centerline of the runway.

(3) *Ammunition and prohibited areas.* No ammunition, explosives, or explosives facilities may be located in A/E prohibited areas as defined below.

(a) The A/E prohibited area for fixed-wing visual flight rules runways, fixed-wing instrument flight rules runways, and rotary-wing instrument flight rules heliports are the ground areas under the normal fixed-wing visual flight rules approach/departure zones as described in UFC 3–260–01 unless local conditions make a larger zone prudent.

(b) The A/E prohibited area for rotary-wing visual flight rules heliports is the ground area under the visual flight rules approach/departure zone for this type of facility as described in UFC 3–260–01.

(c) A/E prohibited area and approach/departure zones begin at the edge of the “landing area” (UFC 3–260–01) for runways and heliport pads.

**Table 8–33**  
**Quantity-distance application for airfields**

To:	From:				
	Combat aircraft parking area	Ammunition/ explosives cargo area	Ammunition/ explosives storage facility	Ammunition/ explosives operating facility	Ready ammunition storage facility
Combat aircraft parking area	3	3	5	5	12
Ammunition/explosives cargo area	3	3	3	3	12
Ammunition/explosives storage facility	3	3	3	3	3
Ammunition/explosives operating facility	4	4	4	4	4
Ready ammunition storage facility	3	3	3	3	3
Inhabited building	1	1	1	1	1
Public traffic route & taxiway (Joint DOD–Non-DOD use)	2	2	2	2	2
Runway (Joint DOD–Non-DOD use)	1	1	1	1	1
Runway/taxiway (DOD component use only)	None	None	11	2	None
Aircraft parking area	10	10	6	6	10
Aircraft passenger loading/unloading area	7	7	7	7	7

**Table 8-33**  
**Quantity-distance application for airfields—Continued**

Recreation area	8	9	9	9	8
-----------------	---	---	---	---	---

Legend for Table 8-33:

1. Use appropriate IBD. A Joint DOD/Non-DOD use runway/taxiway is defined as a runway/taxiway serving both DOD and commercial aircraft. A runway/taxiway serving solely DOD, DOD chartered, or non-DOD aircraft on DOD authorized business (for example, a contractor on business) is not Joint use.
2. Use appropriate PTRD. A Joint DOD/Non-DOD use runway/taxiway is defined as a runway/taxiway serving both DOD and commercial aircraft. A runway/taxiway serving solely DOD, DOD chartered, or non-DOD aircraft on DOD authorized business (for example, a contractor on business) is not Joint use.
3. For HD 1.1 explosives use appropriate IMD. For HD 1.2 explosives, apply note 10, below.
4. Use appropriate ILD.
5. Use table 8-36 distances for mass detonating and appropriate PTRDs for nonmass detonating items.
6. Use table 8-36 distances for Army or other service aircraft parking areas and appropriate IBD for non-DOD aircraft parking areas. A Joint DOD/Non-DOD use runway/taxiway is defined as a runway/taxiway serving both DOD and commercial aircraft. A runway/taxiway serving solely DOD, DOD chartered, or non-DOD aircraft on DOD authorized business (for example, a contractor on business) is not Joint use.
7. Use appropriate PTRDs for locations in the open where passengers board and leave the plane; use appropriate IBD if a structure is included where passengers assemble, such as a passenger terminal building.
8. No distance is required to recreational areas that are used exclusively for alert personnel manning the combat loaded aircraft. Other recreational areas where people are in the open shall be at appropriate PTRD. When structures, including bleacher stands, are a part of such an area, appropriate IBD shall be used.
9. Recreational areas, where people are in the open, shall be at appropriate PTRD. When structures, including bleacher stands, are part of such areas, appropriate IBD shall be used.
10. Within the areas of airfields, heliports, and seadromes used exclusively by the Army or other services, the separation of aircraft parking areas from combat aircraft parking areas and their ready ammunition storage facilities and ammunition and explosives cargo areas are considered to be a command function. At Joint DOD/non-DOD use airfields, heliports, and seadromes, the combat aircraft parking area and its ready ammunition storage facilities and ammunition and explosives cargo area shall be separated from non-DOD aircraft by IBD.
11. Use  $18W^{1/3}$  distances from side or rear of standard earth-covered magazine containing mass detonating items to the taxiway; use appropriate PTRD from the side or rear of standard earth-covered magazines containing non-mass detonating items to the taxiway; use appropriate PTRD from the front of standard earth-covered magazines, and from any other storage location containing mass detonating or non-mass detonating items to the runway.
12. For HD 1.1 explosives use appropriate IMD. For HD 1.2 (1.2.1, HD 1.2.2, and/or HD 1.2.3), apply note 10. Protects against simultaneous detonation of ammunition on adjacent aircraft, but does not prevent serious damage to aircraft and possible propagation of detonation due to fragments, debris, or fire.

**Table 8-34**  
**HD 1.1 QD for military aircraft parking areas**

NEW in pounds	Distance (D=30W <sup>1/3</sup> ) in feet for targets listed in table 8-35	NEW in pounds	Distance (D=30W <sup>1/3</sup> ) in feet for targets listed in table 8-35
50	11	50,000	1,105
100	139	55,000	1,141
200	175	60,000	1,174
300	201	65,000	1,206
400	221	70,000	1,236
500	238	75,000	1,265
600	253	80,000	1,293
700	266	85,000	1,319
800	278	90,000	1,344
900	290	95,000	1,369
1,00	300	100,000	1,392
1,500	343	125,000	1,500
2,000	378	150,000	1,594
3,000	433	175,000	1,678
4,000	476	200,000	1,754
5,000	513	225,000	1,825
6,000	545	250,000	1,890
7,000	574	275,000	1,951
8,000	600	300,000	2,008

**Table 8–34**  
**HD 1.1 QD for military aircraft parking areas—Continued**

9,000	624	325,000	2,063
10,000	646	350,000	2,114
15,000	740	375,000	2,163
20,000	814	400,000	2,210
25,000	877	425,000	2,255
30,000	932	450,000	2,299
35,000	981	475,000	2,341
40,000	1,026	500,000	2,381
45,000	1,067		

Notes:

<sup>1</sup> D in ft, NEWQD in lbs  $D=30W^{1/3}$  with a minimum distance of 111 ft  $NEWQD=D^3/27,000$  with a minimum NEWQD of 50 lbs.

<sup>2</sup> The minimum fragment distance of 1,250 feet for HD 1.1 does not apply to exposures for which this table is used.

<sup>3</sup> If protection from low-angle, high-speed fragments is desired, barricades will be provided; however, distances required by this table will not be reduced.

### 8–33. Pier and wharf facilities

The following separation distance criteria herein are AE composed entirely or in part of HD 1.1. For AE cargo composed of other HDs and no HD 1.1, the applicable QD shall be applied based on the contents of this chapter.

a. This paragraph applies to:

- (1) Ship and barge units, hereafter referred to as ships.
- (2) Piers and wharf and associated facilities at which AE may be handled, or be present in ships' holds or conveyances.

- (3) Loading, off-loading, stowing, and shifting of AE from ships' magazines.

b. Does not apply to (such as, no QD required):

- (1) AE stored in ships' magazines and intended for the service of shipboard armament or aircraft.
- (2) Handling=300 lbs NEW of combined HD 1.3 and HD 1.4 AE that are necessary for ship's security and safety-at-sea.

- (3) Roll-on or roll-off (RORO) operations (not involving lifting), which meet the following requirements:

- (a) The total NEWQD present shall not exceed 50,000 lbs.
- (b) All AE present (such as, in trailers, railcars, barges, ships) must be associated only with the RORO operation being conducted.
- (c) RORO operations shall not exceed 24 hours following arrival of AE, including AE staged at a transshipment point.
- (d) RORO operations shall be located as remote as practicable from populated areas, in order to minimize exposure of unrelated personnel.

c. Determining the Quantity of Explosives in a Ship

- (1) The NEWQD on board a ship shall be determined per table 8–3.
- (2) When ships are separated by  $11W^{1/3}$  distances or greater, QD shall be based individually on the quantity of each ship. Lesser separation distances require that the AE in all ships be totaled.

d. General Cargo and Vehicles at AE Terminals.

- (1) Concurrent movements of mission-related general cargo, vehicles, and AE through a terminal may be conducted for the purpose of loading or unloading the same ship.
- (2) Concurrent operations involving other ships shall be conducted at applicable QD separations. (See figure 8–7).
- (3) Separation of inert materials and equipment in holding areas shall be consistent with paragraph 8–10 and table 8–4.
- (4) Personnel entering inert holding areas that are located within explosive arc shall be limited both in number and time of exposure.

- (5) Any labor intense activity shall take place at IBD or PTRD, as applicable. An exception is permitted when the exposed site is a container loading and unloading operation that routinely supports AE ship-loading and unloading operations.

e. The Prepositioning Program (PREPRO) (for example, Combat Prepositioning Force, Maritime Prepositioning Force, Logistics Prepositioning Ships, and so forth) operates both explosives-loaded and non-explosives carrying ships that are then deployed to key locations around the world. These ships are preloaded with military equipment and

supplies necessary to support military forces on a short notice basis and thus support a common mission. The criteria of table 8-38 apply to PREPO ships at anchorage.

f. Figure 8-7 illustrates required hazard factors. Table 8-40 and table 8-41 provide the corresponding separation distances.

g. Wartime or national emergency. During wartime or national emergencies when contingency ports are being used, the QD required above may be impossible to follow. When the QD above cannot be followed:

(1) Vehicles will be brought up to the dock as close to their loading time as possible. Vehicles will not be allowed to congregate at the dock.

(2) Firefighting equipment will be ready at the dock. Either or a fire boat, fire engine, or 50BC fire extinguishers with at least a 5A capability will be stationed every 100 feet along the dock and in the holding area.

(3) RORO ships are not subject to the requirements of QD.

**Table 8-35**  
**Measurement of separation distances for ships, piers, and anchorages**

PES	Method of Measurement
<b>A Moored Ship or Barge</b>	<p>Measurement of separation distances between ships or barges shall be from the nearest point of one ship's magazine (the potential explosion site) or barge: For IMD: To the nearest point of another ship's magazine or a barge. For IBD and PTRD: To the nearest point of another ship or a barge.</p> <p>Measurement of separation distances between ships or barges and shore exposed sites shall be from the nearest point of a ship's magazine or the barge to the nearest point of the exposed site.</p>
<b>Pier Operations</b>	<p>Measure from the nearest point that AE will be handled to the nearest point of an exposed site.</p> <p>(NOTE: Movement of railcars or trucks passing through the clear space between ships at a pier or between piers is considered as an operational risk. It is generally impracticable to separate berths at a single pier by enough distance to prevent mass detonation of HD 1.1. To the extent operationally feasible, the number of such exposures and total time required should be reduced to the maximum extent practicable through scheduling.)</p>
<b>Anchorage</b>	<p>Boundary of the area designated for the explosives anchorage (See fig 8-6).</p> <p>Separation distance to an exposed site will depend upon whether any ships are separated properly.</p>

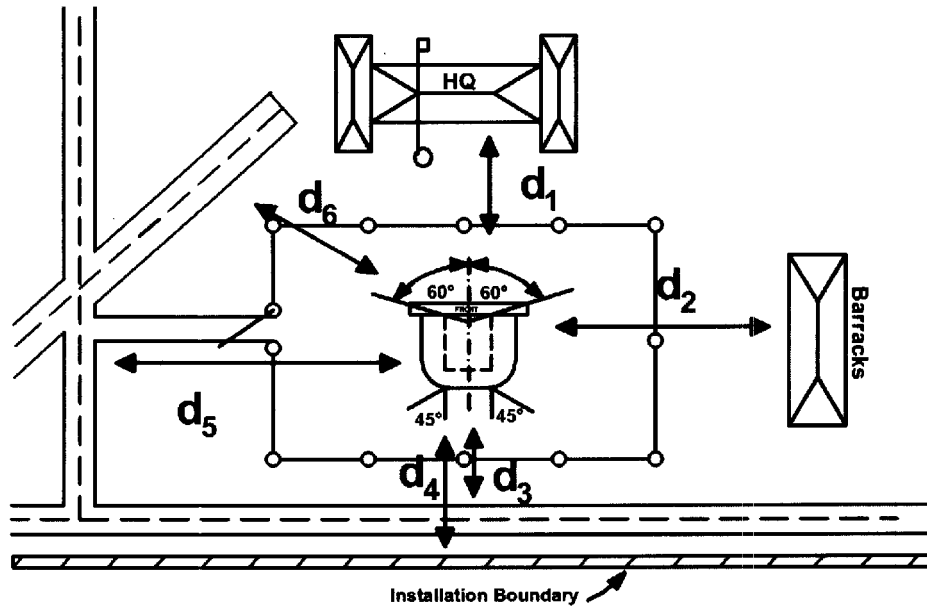

**Notes:**  
 $d_1$  = IBD front exposure distance to HQ  
 $d_2$  = IBD side distance to barracks  
 $d_3$  = PTRD rear distance to road  
 $d_4$  = IBD rear distance to garrison or installation boundary  
 $d_5$  = PTRD side distance to road  
 $d_6$  = PTRD front distance to road

Figure 8-8. Explosives anchorage circle

**Table 8-36**  
**Quantity-distance for maritime prepositioning ships**

Percentage of Load that is HD 1.1	Relationship	QD Factor
52 percent or less	IBD	Use K=40.85 with a 3,700-ft minimum fragment distance <sup>1</sup>
	PTRD	K=24.01
Between 52 and 65 percent		Use table 8-41
Above 65 percent		Use table 8-8
52 percent or less	QD between applicable MPS piers, anchorages, and non-explosives loading piers.	Use K=32 with a 3,500-ft minimum fragment distance
Between 52 and 65 percent	Use table 8-41	
Above 65 percent	Use table 8-8	



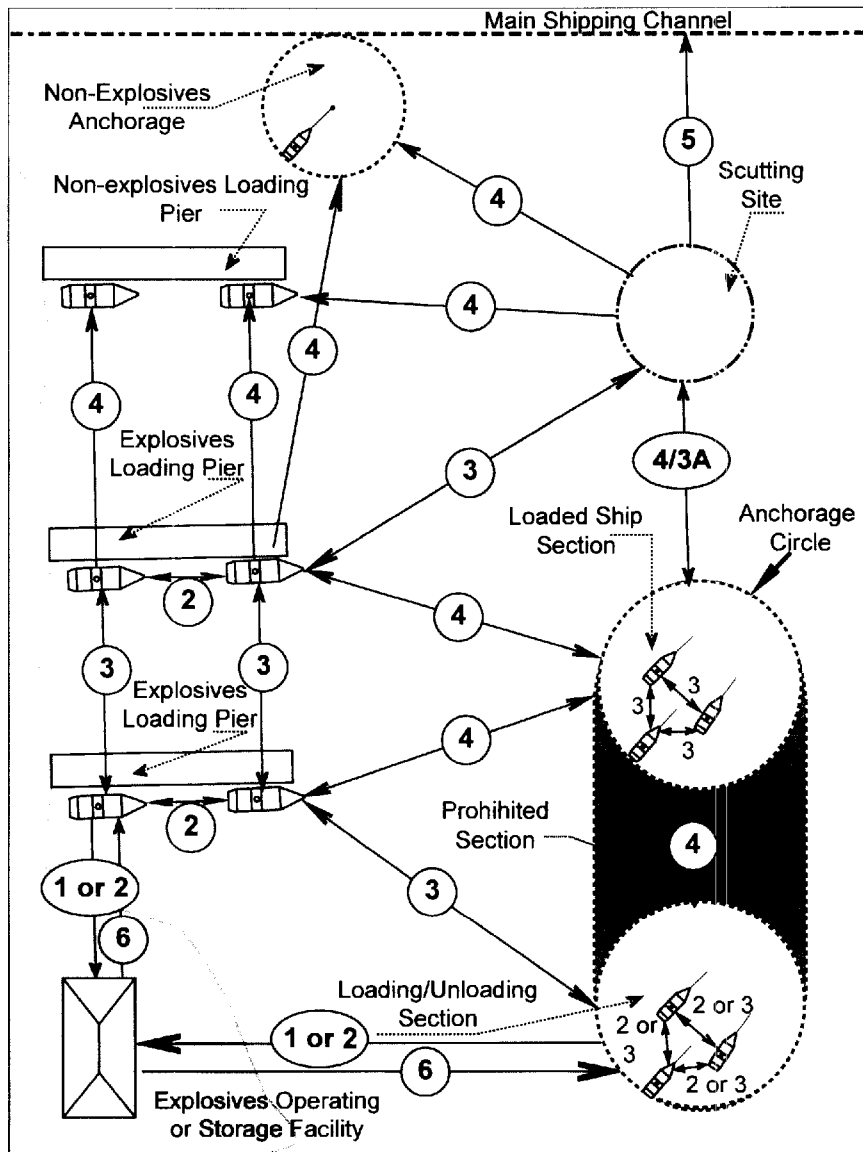

Legend for Figure 8-9;

1 -  $6W^{1/3}$

2 -  $11W^{1/3}$

3 -  $18W^{1/3}$

3A -  $18W^{1/3}$  (See table 8-38 for PREPO ships.)

4 -  $40W^{1/3}$  [ $15.87Q^{1/3}$ ]

5 - Table 8-8 IBD or PTRD ("Other PES" column), as applicable.

6 - Table 8-8 IBD, as applicable.

Figure 8-9. Hazard factors affecting explosives ship and barge QD

**Table 8–37**  
**Application of port facilities quantity-distance**

Site	Distance to use
Scuttling Site	<p>Appropriate QD of table 8–8</p> <p>1. A properly located scuttling site will, when feasible, be provided for positioning a ship for its flooding or sinking in the event it catches fire and must be moved to avert damage to other ships or piers. The location of a scuttling site shall depend on the greatest NEWQD that may be in a single ship at any one time</p> <p>2. The site should have sufficient maneuvering room and depth to permit sinking the largest vessel that may be handled at the garrison or installation so that the holds will be flooded completely at low tide</p> <p>3. The scuttling site should provide the best available protection to other ships, piers, and shore installations in the event of a mass explosion.</p>
Explosives Anchorage	<p>PTRD from “other PES” column of table 8–8 and the turning circles and stopping distances of other ships passing the anchorage but not less than 3,000 ft.</p> <p>Explosives anchorage shall be separated from the main ship channel and from normally traversed routes of ships entering or leaving the harbor by the distances indicated at left. (NOTE: Occasional watercraft passing through the arcs, while outside both the main ship channel and normally traversed routes of ships entering and leaving the harbor, are not subject to QD requirements.)</p>
Separation of ships at explosives anchorages	<p>AE loaded ships are separated one from another by <math>18W^{1/3}</math>.</p> <p>When loading and unloading AE, ships are separated one from the other by <math>11W^{1/3}</math> and, when possible, by <math>18W^{1/3}</math>.</p> <p>Loaded ships are separated from ships loading and unloading AE by <math>40W^{1/3}</math>.</p>
Separation of Explosives Anchorages from Explosives Piers	<p><math>40W^{1/3}</math>, except when the anchorage is used only for the loading or unloading of ships. In that case, <math>18W^{1/3}</math> may be used.</p>
Separation Distances of Ships at the Same Pier	<p>Separate by <math>11W^{1/3}</math></p> <p>Berthing of two ships in tandem helps decrease the fragment hazard to the AE cargo of the second ship because of the additional protection afforded by the bow or stern.</p> <p>When two ships cannot be meet the distance and are being loaded through all hatches at the same time, the spotting of railcars or trucks and the loading of hatches in both ships should be planned in a manner that puts the greatest possible distance both between the open hatches, and the trucks and railcars serving the two ships. When possible, the loading of the ships shall be staggered.</p>
Separation of Wharf Yard from the Pier	<p>A wharf yard will be separated from the pier it serves by <math>11W^{1/3}</math>.</p> <p>If this separation distance cannot be met, then the wharf yard shall be considered as part of the ship or barge and added to it for computation of the total amount of AE for QD purposes.</p>
Separation of Explosives Ships from Other Ships	<p>AE ships being loaded or unloaded shall be separated from non-explosives carrying ships and from loaded explosives ships that are not underway by <math>40W^{1/3}</math>.</p> <p>The PTRD from “Other PES” column of table 8–8 shall be used for protection of ships that are underway.</p>
Barge Piers	<p>Piers and wharfs used exclusively for loading or unloading AE on barges or utility craft may be sited from other shore facilities as loading docks.</p> <p>Shore facilities shall be sited under the same criteria as pier and wharf facilities, in relation to barge piers.</p>
AE loaded ships as exposed site	<p>Separated from AE operating and storage facilities (including holding yards) by the distances specified in the IBD “Other PES” column of table 8–8.</p>

**Table 8–38**  
**Quantity-distance separation of ships**

Relationship	Distance
Non-explosives carrying ships to explosives-loaded ships	By a minimum of $18W^{1/3}$
Nonexplosives ships to PREPO explosives-loaded ships	By $40W^{1/3}$
Nonexplosives carrying ships not associated with the PREPO shall be separated from all explosives carrying ships	By $40W^{1/3}$
All non-explosives carrying ships to explosives ships being loaded or unloaded.	By $40W^{1/3}$

**Table 8–39**  
**Variation of MPS quantity-distance factors with loadout**

Percent HD 1.1	IBD	PTRD	Ship-to-Ship
up to 52 percent	40.85	24.01	32.00
53	40.97	24.08	32.10
54	41.10	24.16	32.19
55	41.22	24.23	32.29
56	41.35	24.30	32.39
57	41.47	24.37	32.48
58	41.59	24.44	32.58
59	41.71	24.52	32.67
60	41.83	24.59	32.77
61	41.95	24.66	32.86
62	42.07	24.73	32.95
63	42.19	24.80	33.05
64	42.30	24.86	33.14
65	42.42	24.93	33.23

**Table 8–40**  
**Quantity-distance separations for pier and wharf facilities (NEW in million pound increments)**

NEW Col 1	DISTANCE (FEET)				
	PTRD Col 2	$11W^{1/3}$ Col 3	$18W^{1/3}$ Col 4	$40W^{1/3}$ Col 5	IBD Col 6
.001	750	110	180	400	1,250
.01	750	235	390	860	1,250
.10	1,115	510	835	1,855	1,855
.25	1,890	690	1,135	2,520	3,150
.50	2,380	875	1,430	3,175	3,970
.60	2,530	930	1,520	3,375	4,215
.70	2,665	975	1,600	3,550	4,440
.80	2,785	1,020	1,670	3,715	4,640
.90	2,895	1,065	1,740	3,860	4,825
1.00	3,000	1,100	1,800	4,000	5,000
1.25	3,230	1,185	1,940	4,310	5,385
1.50	3,435	1,260	2,060	4,580	5,725

**Table 8-40**  
**Quantity-distance separations for pier and wharf facilities (NEW in million pound increments)—Continued**

1.75	3,615	1,325	2,170	4,820	6,025
2.00	3,780	1,385	2,270	5,040	6,300
2.25	3,930	1,440	2,360	5,240	6,550
2.50	4,070	1,495	2,445	5,430	6,785
2.75	4,205	1,540	2,520	5,605	7,005
3.00	4,325	1,585	2,595	5,770	7,210
3.25	4,445	1,630	2,665	5,925	7,405
3.50	4,555	1,670	2,735	6,075	7,590
3.75	4,660	1,705	2,795	6,215	7,770
4.00	4,760	1,750	2,855	6,350	7,935
4.25	4,860	1,780	2,915	6,480	8,100
4.50	4,955	1,815	2,970	6,605	8,255
4.75	5,045	1,850	3,025	6,725	8,405
5.00	5,130	1,880	3,080	6,840	8,550
5.50	5,295	1,945	3,175	7,060	8,825
6.00	5,450	2,000	3,270	7,270	9,085
6.50	5,600	2,055	3,360	7,465	9,330
7.00	5,740	2,100	3,445	7,650	9,565
7.50	5,870	2,155	3,525	7,830	9,785
8.00	6,000	2,200	3,600	8,000	10,000
8.50	6,120	2,245	3,675	8,165	10,205
9.00	6,240	2,290	3,745	8,320	10,400
9.50	6,355	2,330	3,815	8,470	10,590
10.00	6,465	2,365	3,880	8,620	10,770
11.00	6,670	2,440	4,005	8,895	11,120
12.00	6,870	2,520	4,120	9,160	11,445
13.00	7,055	2,585	4,230	9,405	11,755
14.00	7,230	2,655	4,340	9,640	12,050
15.00	7,400	2,715	4,440	9,865	12,330

## **Chapter 9**

### **Explosives Safety in Military Contingency Operations**

#### **9-1. Applicability of provisions outside the United States**

*a.* Full compliance with other chapters may not be possible during military operations other than war (MOOTW) or during contingency deployments. This chapter sets the minimum levels of acceptable risk for contingency deployment ammunition operations in a less than wartime environment. These provisions apply only if permitted by host nation laws and/or Status of Forces Agreements and authorized in writing by the ACOM, ASCC, or DRU commander. Army units stationed at other service installations will follow this chapter to the extent the installation commander allows at the installation.

*b.* The provisions of paragraph 9-10 apply to contingency force operations when specifically approved by the ACOM, ASCC, or DRU commander.

*c.* The provisions of paragraphs 9-11 through 9-15 apply to Army training exercises.

*d.* The provisions of paragraph 9-16 apply to Army airfields in the Theater of Operations used only by military aircraft.

## 9-2. Site plan and licensing process

*a. Explosive locations.* All permanent explosives locations falling within the scope of this chapter shall be approved by the DDESB in accordance with DA Pam 385-64. Site plan packages will be submitted for the following:

- (1) Ammunition storage locations.
- (2) Holding areas and operating locations, such as ports, railheads, ammunition maintenance, repair and renovation areas and sling out areas.
- (3) Forward arming and refueling points (FARPs).
- (4) Combat aircraft parking areas and hot cargo parking areas.
- (5) Static missile batteries (including mobile missile systems employed in static situations).
- (6) Locations used for the treatment or disposal (open burn or detonation) of munitions. Exceptions are those locations used in emergency response and burning excess propellant resulting from munitions use.

*b. Documentation requirements.* The type of documentation required will be determined by the operational situation and the duration of explosives operations conducted at the site or facility. The following general categories of operations apply:

(1) *Contingency and combat training.* Facilities or areas for training activities must either have a DDESB approved site plan or a risk analysis, approved at the appropriate level in accordance with DA Pam 385-30, or both.

(2) *Permanent facilities.* A DDESB approved site plan (through command channels) must be obtained once it is determined that operations will require the facilities' use to exceed 12 months.

(3) *Recurrent facilities.* Those ammunition and explosives related facilities where operations are expected to occur on a periodic basis regardless of the duration of the operation. These locations must have a DDESB approved site plan before commencing operations. Locations may be sited using compensatory actions, such as facility evacuation or change-of-use, to minimize the risks associated with AE operations.

(4) *Temporary.* A plan for the specific scenario shall be approved by the appropriate level of command. The plan shall detail the following:

(a) A risk assessment for the proposed operation. This assessment will weigh need for the facility against the potential effect of a mishap in terms of mission impact, loss of resources, turnaround times, and so forth.

(b) Milestones for transitioning the function to a 'permanent' type of operation or for the cessation of the explosives operations.

*c. Site plan packages.* Site plans will be submitted in accordance with DA Pam 385-65. All explosives safety locations shall be licensed in accordance with chapter 5.

## 9-3. Asset preservation distances

If the risk associated with losing assets due to unplanned events in a tactical environment is unacceptable, use PTRD from the ammunition or explosives to the site to be protected. At this distance, assets are expected to be useable following an incident at a nearby potential explosion site. For 1.1 ammunition items use  $D=(9.5Q^{1/3})/(12Q^{1/3})=(K24/K30)$  and for ammunition classified as 1.2, 1.3 and 1.4 apply the PTRD required in the appropriate table in chapter 8. Note that Q is used to represent the explosives quantity in kilograms whereas W is used to indicate weight in pounds.

## 9-4. Basic load ammunition holding areas

*a. Mission requirement.* To fulfill their missions, certain units must keep their combat load ammunition in readiness within the immediate vicinity of their barracks (in armored vehicles, trucks, trailers, structures or on pads). These storage areas, known as basic load ammunition holding areas (BLAHAs), are comprised of one or more licensed storage sites and involve acceptance of risks to personnel, facilities, and equipment that are greater than permitted by other chapters of this pamphlet. The concept of BLAHA storage may also be used to provide QD separations during mobile operations.

*b. Minimum fragment distance.* The minimum fragment distance requirements of chapter 8 shall be applied to facilities deemed critical to the mission. Housing (both Army personnel and local national) health and morale facilities (except those morale facilities that do not involve construction of buildings such as baseball diamonds, soccer fields, and running tracks or trails) are examples of such locations. For example, an above ground water supply in a desert environment should meet the fragment distance criteria in addition to the QD criteria contained in this chapter. Where it is not possible to meet minimum fragment distance, engineering solutions such as sandbags and barricades may be used.

*c. Mixing of combat load ammunition.* Storage compatibility requirements of chapter 7 do not apply to any licensed explosive site storing 4,000 kg NEQ/8,820 pounds NEW or less of mixed compatibility combat load ammunition.

*d. Net explosive quantity/net explosive weight.* The NEQ in kilograms (NEW in pounds) for use with BLAHA QD criteria will be determined as follows:

- (1) The sum of the weights of all energetic compositions contained in munitions hazard classified as hazard division 1.1 or 1.5 will be used.

- (2) The sum of the explosives weight of all hazard division 1.2 munitions will be used. The propellant weight of a hazard division 1.2 item (if present) may be disregarded.
- (3) The weights of energetic compositions hazard classified as 1.3 may be omitted. If the site only contains 1.3 items the criteria contained in chapter 8 applies.
- (4) The weights of energetic compositions hazard classified as hazard division 1.4 need not be considered for QD computations for BLAHAs.
- (5) The explosives weight of hazard division 1.6 will be computed as follows:
- (a) When hazard division 1.6 is stored alone or with hazard division 1.4 ammunition items, the QD criteria of chapter 8 applies.
- (b) When hazard division 1.6 is stored with ammunition classified as hazard division 1.1, 1.2, or 1.5 add the explosives weight of the 1.6 items into the NEQ calculations.
- (c) When hazard division 1.6 is stored with ammunition classified as hazard division 1.3 add the explosives weights of the hazard division 1.3 and hazard division 1.6 (the QD criteria of chapter 8 applies).
- e. Explosives limits.*
- (1) The maximum NEQ/NEW at any licensed site in a BLAHA storing mixed compatibility combat load ammunition must not exceed 4,000 kg/8,820 lb. A single BLAHA may have multiple 4,000 kg (8,800 lb) sites, provided the BLAHA sites are separated by the appropriate D1, D2 or D3 distances given in table 9-1.
- (2) When the BLAHA or site within a multiple bay BLAHA exceeds 4,000 kg (8,800 lb), the QD computations for that BLAHA site will be per chapter 8 and explosives compatibility storage criteria of chapter 7 applies.
- f. Quantity-distance computations (table 9-1).*
- (1) The total NEQ/NEW of ammunition in each site shall be used for computation of QD provided the required distances necessary to prevent propagation separate these items. If the distances are not met the entire BLAHA shall be considered one site.
- (2) The IMD requirements of chapter 8 apply when using standard (3-bar or 7-bar) earth-covered magazines.
- (3) Table 9-1 contains the QD separation for BLAHAs as explained below:
- (a) Column D-1 is used for—
1. Side-to-side, side-to-rear, and rear-to-rear exposures between undefined earth-covered magazines (ECMs), provided the earth cover complies with paragraph 8-16, and the explosives are stored at least one meter (3 feet) from the end of the shelter.
  2. Non-armored sites to non-armored sites when an adequate barricade is located between the sites.
  3. Light armored vehicles to an unarmored exposed site's when adequate barricade near the non-armored exposed site.
  4. Light armor or non-armored PESS to light armored exposed sites when an adequate barricade is located between the sites.
- (b) Column D-2 is used for—
1. Front-to-front exposures involving undefined ECMs when there is an adequate barricade at the exposed site.
  2. Non-armored or light armored sites to the side or rear of an undefined ECM.
- (c) Column D-3 is used for:
1. Non-armored sites to non-armored sites without an adequate barricade.
  2. Light armored vehicles to non-armored sites without an adequate barricade at the non-armored site.
  3. Undefined ECM to undefined ECM when positioned front-to-front and no barricade is present.
  4. Non-armored sites, light armored sites or undefined ECMs to the front of undefined ECM when no barricade is present at the exposed site.
- (d) Column D-4 is used for PTRD separations from non-armored and light armored vehicles and sites.
- (e) Column D-5 is the IBD separation from non-armored and light armored vehicles or sites.
- (f) Column D-6 is used to determine the IBD and PTRD separation from heavy armored vehicles. When NEQ exceeds 150 kg (330 lb) the IBD and PTRD separation distances specified in chapter 8 apply.
- (4) Heavy armored vehicles are expected to largely contain the blast and fragments from an internal explosion and are well protected from an external explosion. For this reason there is no required separation from heavy armor to light or non-armored sites. Additionally, heavy armor requires no separation from other sites (heavy armor being the exposed site). The hatches of heavy armored vehicles must be kept closed to consider them as heavy armor.
- (5) The QD requirements for heavy, light and non-armored vehicles or sites are contained in table 9-2.
- (6) Use  $D=(9.5Q^{1/3})/(12Q^{1/3})=(K24/K30)$  instead of D-1, D-2, and D-3 for asset preservation.
- (7) The total NEQ/NEW of ammunition in all trucks or trailers within a truck or trailer park will be used for QD computations if the trucks or trailers within a park occupy one storage site and are not separated from each other by QD specified in paragraph (2), above.
- (8) IMD requirements of chapter 8 apply when combat load ammunition is stored in standard magazines. When earth-covered shelters of light construction; for example, a MILVAN covered with dirt, are used, the D1 distances in

table 9-1 apply to side-to-side configurations provided the earth cover complies with paragraph 8-16, and the explosives are stored at least 1 meter from the end of the shelter. If end-to-end sitings are involved, the D2 distances apply provided there is a barricade. The D-3 distances apply if there is no barricade.

(9) The Bradley Fighting Vehicle is expected to contain blast and fragments from its HD 1.2, 25 mm ammunition.) If a Bradley is only uploaded with 25 mm ammunition it can be consider as 'heavy' armor.

(10) Barracks, headquarters, and maintenance facilities within a military garrison or installation will be separated from mixed compatibility, combat load ammunition of less than 4,000 kg NEQ/8,820 pounds NEW by D5 distances in figure 9-1.

(11) Detonators and/or blasting caps, when stored with combat load ammunition, will be separated from other types of explosives by a heavy dividing wall. Sandbags, heavy inert material (bomb fins), or small arms ammunition may be used for this purpose. The wall must be stable and provide line-of-sight protection to the other explosives.

NEWQD (lbs) [kg]	D1 <sup>1</sup> (ft) [m]	D2 <sup>2</sup> (ft) [m]	D3 <sup>3</sup> (ft) [m]	D4 <sup>4</sup> (ft) [m]	D5 <sup>5</sup> (ft) [m]	D6 <sup>6</sup> (ft) [m]
10	4	13	26	591	886	66
4.5	1.3	3.9	7.9	180	270	20
15	5	15	30	591	886	66
6.8	1.5	4.5	9.0	180	270	20
20	5	16	33	591	886	66
9.1	1.7	5.0	9.9	180	270	20
30	6	19	37	591	886	66
13.6	1.9	5.7	11.4	180	270	20
50	7	22	44	591	886	66
22.7	2.2	6.7	13.5	180	270	20
70	8	25	49	591	886	66
31.8	2.5	7.5	15.1	180	270	20
100	9	28	56	591	886	66
45.4	2.8	8.5	17.0	180	270	20
150	11	32	64	591	886	81
68.0	3.2	9.7	19.4	180	270	24.6
200	12	35	70	591	886	99
90.7	3.6	10.7	21.4	180	270	30.0
300	13	40	80	591	886	130
136.1	4.1	12.2	24.5	180	270	39.6
500	16	48	95	591	886	
226.8	4.8	14.5	29.0	180	270	
700	18	53	107	591	886	
317.5	5.4	16.2	32.5	180	270	
1,000	20	60	120	591	886	
453.6	6.1	18.3	36.6	180	270	
1,500	23	69	137	591	886	
680.4	7.0	20.9	41.9	180	270	
2,000	25	76	151	591	886	
907.2	7.7	23.0	46.1	180	270	
3,000	29	87	173	591	886	
1,360.8	8.8	26.4	52.8	180	270	
5,000	34	130	205	591	886	
2,268.0	10.4	31.3	62.5	180	270	
7,000	38	115	230	591	886	
3,175.1	11.7	35.0	70.0	180	270	
8,818	41	124	248	591	886	
4,000	12.6	37.8	75.6	180	270	

Note:

- For D1 (NEWQD in lbs, D1 in ft):  
 $D1 = 2 * \text{NEWQD}^{1/3}$   
 $\text{NEWQD} = (D1/2)^3$  (8,818 lbs maximum)  
  
For D1 (NEWQD in kg, D1 in m)  
 $D1 = 0.79 * \text{NEWQD}^{1/3}$   
 $\text{NEWQD} = (D1/0.79)^3$  (4,000 kg maximum)
- For D2 (NEWQD in lbs, D2 in ft):  
 $D2 = 6 * \text{NEWQD}^{1/3}$   
 $\text{NEWQD} = (D2/6)^3$  (8,818 lbs maximum)  
  
For D2 (NEWQD in kg, D2 in m)  
 $D2 = 2.38 * \text{NEWQD}^{1/3}$

Figure 9-1. Quantity-distance table for basic load ammunition holding areas



- $NEWQD = (D2/2.38)^3$  (4,000 kg maximum)
3. For D3 (NEWQD in lbs, D3 in ft):  
 $D3 = 12 * NEWQD^{1/3}$   
 $NEWQD = (D3/12)^3$  (8,818 lbs maximum)  
 For D3 (NEWQD in kg, D3 in m)  
 $D3 = 4.76 * NEWQD^{1/3}$   
 $NEWQD = (D3/2.38)^3$  (4,000 kg maximum)
  4. For D4 (NEWQD in lbs, D4 in ft):  
 $NEWQD < 5,500$  lbs D4 = 591 ft.  
 $5,500$  lbs <  $NEWQD < 8818$  lbs D4 =  $8 * NEWQD^{1/2}$   
 $D4 < 591$  ft  $NEWQD = 0$  lbs  
 $591$  ft <  $D4 < 751$  ft  $NEWQD = (D4/8)^2$  (8,818 lbs maximum)  
 For D4 (NEWQD in kg, D4 in m)  
 $NEWQD < 2,495$  kg D5 = 180 m  
 $2,495$  kg <  $NEWQD < 4000$  KG D4 =  $3.62 * NEWQD^{1/2}$   
 $D4 < 180$  m  $NEWQD = 0$  kg  
 $180$  m <  $D4 < 229$  m  $NEWQD = (D4/3.62)^2$  (4,000 kg maximum)
  5. For D5 (NEWQD in lbs, D5 in ft):  
 $NEWQD < 5,500$  lbs D5 = 886 ft.  
 $5,500$  lbs <  $NEWQD < 8818$  lbs D5 =  $12.2 * NEWQD^{1/2}$   
 $D5 < 886$  ft  $NEWQD = 0$  lbs  
 $886$  ft <  $D5 < 1146$  ft  $NEWQD = (D5/12.2)^2$  (8,818 lbs maximum)  
 For D5 (NEWQD in kg, D5 in m)  
 $NEWQD < 2,495$  kg D5 = 270 m  
 $2,495$  kg <  $NEWQD < 4000$  KG D5 =  $5.43 * NEWQD^{1/2}$   
 $D5 < 270$  m  $NEWQD = 0$  kg  
 $270$  m <  $D5 < 343.4$  m  $NEWQD = (D5/5.43)^2$  (4,000 kg maximum)
  6. When NEWQD exceeds 331 lb (150 kg) the IBD and PTRD specified in chapter 8 apply.  
 For D6 (NEWQD in lbs, D6 in ft):  
 $NEWQD < 110$  lbs D6 = 66 ft  
 $110$  lbs <  $NEWQD < 331$  lbs  $D6 = -4.49 + 0.487 * (NEWQD^{1/3}) + 2.928 * (NEWQD^{1/3})^2$   
 $D6 < 66$  ft  $NEWQD = 0$  lbs  
 $66$  ft <  $D6 < 138$  ft  $NEWQD = (0.0833 + [1.5421 + 0.3416 * D6]^{1/2})^3$   
 For D6 (NEWQD in kg, D6 in m)  
 $NEWQD < 50$  kg D6 = 20 m  
 $50 < NEWQD < 150$  kg  $D6 = -1.37 + 0.193 * (NEWQD^{1/3}) + 1.512 * (NEWQD^{1/3})^2$   
 $D4 < 20$  m  $NEWQD = 0$  kg  
 $20$  m <  $NEWQD < 42.3$  m  $NEWQD = (0.0640 + [0.9108 + 0.6615 * D6]^{1/2})^3$

Figure 9–1. Quantity-distance table for basic load ammunition holding areas–Continued

Table 9–1  
Quantity-distance for armored vehicles

FROM potential explo- sion site	TO exposed site				
	HEAVY	LIGHT	NON-ARMORED	PTRD	IBD
HEAVY	N/R	N/R	N/R	D6	D6
LIGHT	N/R	D1	D3	D4	D5
NON-ARMORED	N/R	D1	D3	D4	D5

Notes:

<sup>1</sup> N/R=not required.

### 9–5. Combat load storage in other than BLAHAs

a. Individual magazines, sheds, pads, or other licensed storage sites within a wholesale or retail level activity may be designated as combat load storage sites.

b. Each designated combat load storage site containing mixed compatibility combat load ammunition will not contain prepositioned war reserves (PPWR) ammunition or other ammunition stock. Training ammunition may be stored in a facility with combat load ammunition but will be stacked separately.

- c.* Each designated combat load storage site must comply with all provisions of paragraph 9–4.
- d.* Compatible combat load ammunition may be stored with compatible PPWR in accordance with chapter 8.

### **9–6. Vehicle and equipment maintenance**

- a.* Maintenance of military vehicles and equipment, when the maintenance work is performed exclusively by and for the military personnel of the unit or units storing ammunition at the BLAHA, must be separated from the potential explosion site by D5 distance.
- b.* Crew-level maintenance may be performed on an uploaded vehicle without downloading ammunition. However, ammunition-laden vehicles undergoing authorized minor maintenance must be separated from fire and spark or flame producing devices by at least 50 feet.
- c.* Ammunition will be removed from vehicles scheduled for repair or maintenance requiring welding or torch cutting, disassembling fuel or electrical systems, or removing power packs.
- d.* Ammunition must be downloaded before vehicles are delivered to contact teams or shop areas.
- e.* Ammunition downloaded from vehicles undergoing maintenance or repair must be removed to a licensed ammunition storage area, stored in a licensed ammunition download rack, or loaded in an extra or standby vehicle. Ammunition may not be stored, even temporarily, in a BLAHA unless it meets all the provisions of paragraph 9–4.
- f.* Ammunition may be downloaded from vehicles in a BLAHA or vehicle park provided the ammunition is immediately removed in accordance with paragraph 9–6e, above.

### **9–7. Fire prevention**

- a.* Vehicles and trailers loaded with ammunition and explosives should not be parked with vehicles and trailers transporting flammable liquids/packaged gasoline, diesel fuel and similar flammable/combustible liquids. If no other viable option is available and composite risk management has reduced the risk to an acceptable level maintain the fuel at least 100 feet away and downhill from the ammunition and explosives laden trucks.
- b.* A fire plan will be posted for evacuation of combat loaded vehicles in a BLAHA. The fire plan for uploaded armored vehicles will include provisions for a quarterly fire drill for armored vehicle crews.
- c.* When tactical situations permit, refueling operations for vehicles carrying ammunition should be delayed until the engine has cooled for at least 10 minutes to lessen the danger of automatic ignition from spills or overflows.

### **9–8. Surveillance**

- a.* Ammunition surveillance inspections of combat load ammunition will be separated from each potential explosion site in accordance with paragraph 3–2j.
- b.* In the case of uploaded tank parks, where drastically reduced distances separate uploaded tanks from inhabited buildings, no more than three tanks at a time may be downloaded for surveillance inspections. Whenever possible, ammunition should be removed to a licensed storage facility for surveillance operations.

### **9–9. Storage**

Certain static storage provisions of this pamphlet do not apply to the mission-oriented storage of combat load ammunition in BLAHA facilities.

- a.* Manual MHE may be stored with combat load ammunition if the MHE is used exclusively for the transfer of the ammunition from the structure where it is stored.
- b.* Separation of ammunition lots is not required for combat load combat configured load (CCL). As one lot of ammunition may exist in several locations within one storage structure, lot will be identified with a placard attached to each load, listing, by DODIC, all lot numbers and quantities in the load.
- c.* Fire and chemical hazard symbols are required only on the main gate (and other gates used by fire fighting forces) of a BLAHA if both of the following provisions are met:
  - (1) All storage sites within the BLAHA are visible from the main gate.
  - (2) All storage sites within the BLAHA store 4000 kg NEQ/8820 pounds NEW or less mixed compatibility combat load ammunition.
- d.* Artillery projectiles and associated propelling charge may be stored in a loose configuration when the upload procedures do not include using powered or power-assisted material handling equipment. When stored loose, these items must be secured so that they will remain secure and stable. Projectiles should be stored with the original pallet top and base with the cut banding removed.
- e.* To decrease response times, ammunition to be immediately uploaded during an alert or contingency may be stored in containers that can be easily opened. When consistent with security requirements, banding may be removed and nailed covers loosened to the extent that further use of tools is not required.
- f.* Dunnage between non-cleated boxes of unpalletized combat load ammunition is not required.

### **9–10. Combat load storage ammunition holding areas in the United States**

- a.* In accordance with paragraph 7–3b, certain U.S. locations, designated by the Army, and site approved by the

DDESB, to store ammunition and explosives packages in configuration for rapid response, for example, Rapid Deployment Force, are authorized to mix compatibility groups as required to achieve the optimum load required by the using units. The maximum NEQ/NEW at any of these locations must not exceed 4000 kg/8820 pounds calculated in accordance with paragraph 9-4d.

b. All the provisions of paragraphs 9-4 through 9-9 apply to BLAHA storage in the U.S. except that the QD requirements of chapter 8 of this pamphlet apply. Use of the relaxed QD provisions of table 9-1 is not authorized.

### **9-11. General requirements for training operations**

Realistic training with ammunition and explosives in peacetime is an inherently hazardous operation involving constant risk assessment, a greater degree of risk acceptance, and a heightened awareness of explosives safety. (Explosives safety criteria for training operations on firing ranges are contained in DA Pam 385-63.)

### **9-12. Upload exercises**

The live ammunition upload exercise, testing reaction times, load times, and trafficability plans are the most common Army go-to-war exercise performed by forward-deployed troops. These exercises are authorized, without regard to QD criteria at upload sites, with the following restrictions:

a. There will be no relaxation in standards governing vehicle, fire prevention, ammunition-handling or transportation safety required by other portions of this pamphlet.

(1) Vehicles must be inspected before entering the ammunition storage area. Vehicles which do not pass the inspection will not participate further in the upload portion of the exercise unless deficiencies are corrected.

(2) Fire or spark producing devices, including matches and cigarette lighters, will not be permitted in the ammunition storage area. Smoking will not be permitted except in authorized areas. Two handheld fire extinguishers (see para 6-10) must be present and ready for immediate use at each pad, building, and so forth, when ammunition is handled.

(3) Ammunition must be handled carefully. Containers must not be tumbled, dropped, thrown, or rolled. Only containers designed for dragging may be dragged.

(4) Loaded weapons will not be allowed in storage structures containing ammunition.

(5) During the loading or unloading of vehicles, the parking brakes must be set, the engine turned off, and at least one wheel chocked. Vehicles uploaded with ammunition must have the weight properly distributed and the load secured to prevent movement. The unit commander must ensure the load is checked and complies with governing transportation requirements before the load is moved. Palletized loads of ammunition on vehicles with load bearing sideboards must not have over one-third the height of the pallet extending above the sides or tailgates, and unpalletized loads must not extend above the sides or tailgates. All vehicles must be uploaded in accordance with the loading and tiedown procedures contained in approved drawings.

b. Exposure of units to their ammunition will be limited to the minimum number of persons, for a minimum amount of time and the minimum amount of ammunition consistent with safe and efficient operations.

(1) Only personnel essential to the uploading or downloading of ammunition will be permitted at the loading site.

(2) Nonessential personnel or those waiting for access to magazines will be kept at the maximum practical distance from the loading site.

(3) Upon completion of the upload portion of the exercise, the unit will immediately download unless:

(a) The uploaded vehicle is blocking the access of another unit or vehicle to its ammunition.

(b) The exercise involves moving the ammunition to a local dispersal area.

(c) Safety considerations, such as darkness or weather conditions, intervene.

c. Local dispersal areas, or other collection points for uploaded vehicles, will meet the QD requirements of chapter 8.

d. Uploaded vehicles awaiting download will be directed to locations within the garrison or installation which do not compromise external QD restrictions and which present the least internal hazard.

e. Where space on the garrison or installation permits, uploaded vehicles will be parked a minimum of 10 meters from other uploaded vehicles to facilitate isolating a burning vehicle.

(1) Where space on a garrison or installation does not permit 10 meters separation between uploaded vehicles, collection points may be established. These collection points will be treated as aboveground magazines provided the NEQ/NEW does not exceed 4000 kg/8820 pounds as computed in paragraph 9-4 d. If these weights are exceeded, the collection point will be treated as a holding yard and sited in accordance with chapter 8.

(2) Under no circumstances should vehicles be forced off a storage site garrison or installation onto public roads for the sole purpose of meeting QD restrictions.

### **9-13. Combat configured loads**

a. The CCLs are authorized to use "Z" compatibility (see fig 7-4) and are an exception to lot separation requirements in accordance with paragraph 9-9b.

b. Sites for exercises designed to practice the construction of CCLs will be separated from each storage potential explosion site by at least IL(U) distance.

c. Exercises designed to practice the upload of ammunition before the assembly and construction of CCLs will be conducted in accordance with paragraph 9–12.

#### **9–14. Aviation operations at basic load ammunition holding areas**

a. Helicopter landing areas for loading and unloading ammunition within storage sites and quick reaction alert sites will be considered aboveground magazines and may be sited at appropriate quantity-distance based only upon explosives on board the helicopters. IMDs will apply to magazines and maintenance buildings subject to the following requirements:

- (1) Flight clearance criteria are met.
- (2) Landing and takeoff approaches will not be over magazines.
- (3) Helicopter operations will be limited to ammunition support of the magazines concerned. Carrying passengers is not permitted. Troops and ammunition may be transported by the same helicopter when—
  - (a) The soldiers are members of a weapon crew.
  - (b) The helicopter is servicing their weapons.
- (4) Safety precautions normal to other modes of transportation are to be observed.
  - (a) Explosives operations will not be conducted in magazines or maintenance buildings located within IBD from the helicopter landing area during takeoff, landing or loading/off-loading of the helicopters. These magazines and buildings will be closed.
  - (b) Ammunition upload exercises involving ground vehicles will not take place during helicopter upload exercises unless the two exercises are separated by at least IL(U) distance.

b. During sling-load exercises, dummy loads should be constructed to simulate the size, weight, and shape of the ammunition. If live ammunition is used, all of the provisions of paragraph 9–14a, above, must be followed.

#### **9–15. Forward area rearm and refuel points**

a. The FARPs shall be separated by IBD from all non-associated inhabited buildings. In the United States, its territories, and possessions this distance will be computed in accordance with chapter 8. In locations outside the United States where use of paragraphs 9–4 through 9–9 is authorized, D5 distances of table 9–1 apply.

b. Ammunition placement sites will be a prudent fire distance away from fuel storage sites, but in no case less than 100 feet. Fuel supplies shall be diked or placed downhill from the ammunition and explosives.

c. Armament pads will contain the minimum amount of munitions to conduct efficient operations. In no case will the amount of munitions exceed the amount required to arm the maximum number of helicopters that can be refueled at one time. The ready ammunition storage (that ammunition staged to support the next load) shall be separated by aboveground magazine distance from the armament pads, with only the armament pads considered as the potential explosion site. Ready ammunition storage structures shall be separated from other ready ammunition storage structures by aboveground magazine. Buildup locations shall be separated by aboveground magazine distance from all other explosives storage locations and operations with only the buildup location considered as the potential explosion site.

d. Ammunition brought to the helicopter for rearming will not be placed on a fuel spill. Ammunition should be kept at least 100 feet away from waste fuel pans.

e. Rearming will not begin until the aircrew has signaled that all weapons systems have been safed and the aircraft engine has been reduced to flight idle. Rearming will begin with the turret weapon system and the wing stores opposite the fueling port during the refueling operations.

f. When loading electrically initiated missiles or rockets, stray voltage must be eliminated before loading. The aircraft will be grounded during rearming.

g. Ammunition loading crew members splashed with fuel must immediately leave the load area.

h. Excess and empty packaging material must be kept clear of the refueling point.

#### **9–16. Airfield operations**

a. *General.*

(1) Special consideration must be given to phased plans where the peacetime operation and positioning of aircraft transitions to contingency operations with increased quantities and use of explosives. Exposures given adequate protection under the peacetime phase may be placed at greater levels of risk during the contingency phase. Commanders must consider these changes when approving these plans.

(2) The proper use of such features as barricades or earth-filled, steel-bin-type barricades (ARMCO Revetment or equivalent) can decrease the size of a potential explosive event and increase the explosives capacity of limited areas.

b. *Airfield quantity-distance criteria.*

(1) Potential explosion site criteria. Table 9–6 provides criteria for airfield PESs.

(2) Exposed site criteria.

(a) Runways, taxiways and combat cargo aircraft. For military use runways and taxiways use table 9–6. For Joint use runways and taxiways, use criteria in chapter 8.

(b) Combat aircraft support facilities. Unhardened combat aircraft support facilities shall be separated from munitions storage and operating facilities by  $D=12Q^{1/3}$  (K30). For asset preservation, apply incremental  $D=16Q^{1/3}$  to  $20Q^{1/3}$  (K40 to K50) based on the NEW. If these functions are located in a HAS, separation can be reduced to  $D=7.1Q$  (K18) to the sides or rear. Site other hardened facilities as approved by the DDESB. Combat aircraft support facilities may be sited at ILD under reduced criteria when the additional risk to personnel and resources is accepted.

c. *Hardened aircraft shelters.*

(1) As a minimum, HAS and associated storage facilities shall be separated one from another according to table 9–3. At these distances there will be a high degree of protection against propagation of explosion when HAS doors are properly secured. However the exposed shelter may be heavily damaged and aircraft and ammunition therein may be rendered unserviceable.

(2) HAS and associated storage facilities spaced according to table 9–4 will provide a higher degree of asset preservation than those provided in table 9–3. An explosion in one shelter or ready storage facility may destroy it and its contents, but aircraft within adjacent shelters will be undamaged provided the doors are closed. These aircraft may not be immediately removable due to debris.

(3) Areas of hazard to front, side, or rear of HAS or ECMs as potential explosion site, or Exposed sites lie in the arcs shown in figure 9–1. A particular face of an exposed site is threatened by a potential explosion site face when both of these faces lie within the arc of threat or hazard of the other. Hardened aircraft shelter as an exposed site figure 9–2. Hardened aircraft shelter as a potential explosion site.

(4) When the potential explosion site is a third-generation HAS containing up to 5,000 kg (11,000 lb) NEQ (NEW) minimum distances from the front, sides and rear given in table 9–5 shall be used to protect an unhardened exposed site against debris and blast. The QD criteria given in table 9–5 apply to all hazard division 1.1 ammunition and explosives regardless of any minimum fragment distance denoted by (xx)1.1. When operational necessity dictates, distances less than those contained in tables 9–2 and 9–3 may be approved for Exposed sites. However, it must be shown that protection equivalent to K18 is being provided.

d. *Aircraft with installed explosives and safety devices.* Aircraft that contain only installed explosives and safety devices such as, authorized signals in survival kits, egress systems components, engine-starter cartridges, fire extinguisher cartridges, and other such items necessary to flight operations are not regarded as PESs under the provisions of this chapter.

**Table 9–2**  
**Minimum hazard factor for hardened aircraft shelters for propagation prevention**

TO exposed site		1st Generation HAS			FROM potential explosion site			2d and 3d Generation HAS			Ready Service ECM			Ready Service AGM		
		S	R	F	S	R	F	S	R	FB	FU	B	U			
<b>1st Generation HAS</b>	<b>S</b>	2	2	2.75	2	2	2.27	1.25 <sup>1</sup>	1.25 <sup>1</sup>	2.75 <sup>2</sup>	2.75 <sup>2</sup>	2.75	2.75			
	<b>R</b>	2	2	2.75	2	2	2.75	1.25 <sup>1</sup>	1.25 <sup>1</sup>	2.75 <sup>2</sup>	2.75 <sup>2</sup>	2.75	2.75			
	<b>F</b>	6	4.5	8	6	4.5	9	1.25 <sup>1</sup>	2.75 <sup>2</sup>	6 <sup>2</sup>	9 <sup>2</sup>	6	9 <sup>2</sup>			
<b>2d &amp; 3d Generation HAS</b>	<b>S</b>	2	2	2.75	2	2	2.75	1.25 <sup>1</sup>	1.25 <sup>1</sup>	2.75 <sup>2</sup>	2.75 <sup>2</sup>	2.75	2.75			
	<b>R</b>	2	2	2.75	2	2	2.75	1.25 <sup>1</sup>	1.25 <sup>1</sup>	2.75 <sup>2</sup>	2.75 <sup>2</sup>	2.75	2.75			
	<b>F</b>	4.5	2.75	5	4.5	2.75	0	1.25 <sup>1</sup>	1.25 <sup>1</sup>	2.75 <sup>2</sup>	2.75 <sup>2</sup>	2.75	2.75			
<b>Ready Service ECM</b>	<b>S</b>	2	2	2.75	2	2	2.75									
	<b>R</b>	2	2	2.75	2	2	2.75									
	<b>FB</b>	2.75	2.75	5	2.75	2.75	6									
<b>Ready Service AGM</b>	<b>FU</b>	6	4.5	8	6	4.5	9									
	<b>B</b>	2.75	2.75	6	2.75	2.75	6									

**Table 9–2**  
**Minimum hazard factor for hardened aircraft shelters for propagation prevention—Continued**

TO exposed site		FROM potential explosion site											
		1st Generation HAS			2d and 3d Generation HAS			Ready Service ECM			Ready Service AGM		
	<b>U</b>	11	11	11	11	11	11						

Legend for Table 9-2:

S-side; R-rear; F-front, B-barricaded; U-unbarricaded

Notes:

<sup>1</sup> Use  $d=2W^{1/3}$  if the loading density of the ECM exceeds 1.25 lbs/ft<sup>3</sup> NEW. Do not exceed the maximum NEW limit of 22,000 lbs for 1st Generation HAS and 11,000 lbs for 2nd and 3rd Generation HAS.

<sup>2</sup> If required, use the separation shown regardless of loading density. Do not exceed the maximum NEW limit of 22,000 lbs for 1st Generation HAS and 11,000 lbs for 2nd and 3rd Generation HAS.

<sup>3</sup> Second and third-generation hardened aircraft shelters are limited to a minimum of 11,000 lbs per shelter.

**Table 9–3**  
**Minimum hazard factor for hardened aircraft shelters for asset prevention**

TO exposed site		FROM potential explosion site											
		1st Generation HAS			2d and 3d Generation HAS			Ready Service ECM			Ready Service AGM		
		<b>S</b>	<b>R</b>	<b>F</b>	<b>S</b>	<b>R</b>	<b>F</b>	<b>S</b>	<b>R</b>	<b>FB</b>	<b>FU</b>	<b>B</b>	<b>U</b>
<b>1st Generation HAS</b>	<b>S</b>	9	6	9	9	6	9	2.75	2.75	8	8	8	8
	<b>R</b>	8	5	8	8	5	8	2.75	2.75	8	8	8	8
<b>2d and 3d Generation HAS</b>	<b>F</b>	18	18	18	18	18	18	11	9	18	18	18	18
	<b>S</b>	9	6	9	9	6	9	2.75	2.75	8	8	8	8
<b>1st Generation HAS<sup>1</sup></b>	<b>R</b>	8	5	8	8	5	8	2.75	2.75	8	8	8	8
	<b>F</b>	11	9	18	11	9	18	2.75	2.75	8	8	8	8
	<b>S</b>	9	8	9	9	8	9	8	8	8	8	8	8
<b>2d and 3d Generation HAS</b>	<b>R</b>	8	8	8	8	8	8	8	8	8	8	8	8
	<b>F</b>	18	18	18	18	18	18	11	9	18	18	18	18
	<b>S</b>	9	8	9	9	8	9	8	8	8	8	8	8
	<b>F</b>	11	9	18	11	9	18	8	8	8	8	8	8

Legend for Table 9-3:

S-side; R-rear; F-front, B-barricaded; U-unbarricaded

Notes:

<sup>1</sup> Maintenance HAS will not be located closer than 300 feet from any HAS potential explosion site sited for more than 500 lbs NEW.

<sup>2</sup> 2nd and 3rd Generation HAS are limited to a maximum NEW of 11,000 lbs per shelter.

<sup>3</sup> Ready service ECM storage is used to support daily loading and is limited to 22,000 lbs (10,000 kgs) per magazine and loading density not more than 1.25 lbs NEW per cubic foot. (20 kg per cubic meter).

**Table 9-4**  
**Quantity-distance from a U.S. third-generation hardened aircraft shelter potential explosion site to an unhardened exposed site**  
 1,2

NEQ, kg (NEW, lb)					
From	To	Note	Front, m (ft)	Sides, m(ft)	Rear, m (ft)
0	2(4.4)	3	15(50)	15(50)	15(50)
2(4.4)	50(110)	3	70(230)	15(50)	15(50)
50(110)	225(500)	3	70(230)	15(50)	15(50)
225(500)	500(1,100)	3	70(230)	120(394)	50(50)
500(1,100)	5,000(11,100)	3	20Q <sup>1/3</sup> [K50]	25Q <sup>1/3</sup> [K63]	16Q <sup>1/3</sup> [K40]

Notes:

<sup>1</sup> Separations are based on shelter doors remaining closed, except for aircraft towing, fueling, servicing, run-up, or taxi and during integrated combat turnarounds or short periods when maintenance equipment or munitions are being moved into or out of the shelter. Where doors are left open for extended periods, normal combat aircraft parking area criteria apply.

<sup>2</sup> Munitions should be separated from the hardened aircraft shelter walls at a distance sufficient to eliminate local breaching. For less than 500kg, (1,100 lb) a one meter (three feet) separation from the wall is sufficient.

<sup>3</sup> The quantity-distance criteria in the table apply to IBD, PTRD, and ILD exposures for quantities less than equal to 500 kg.

<sup>4</sup> For quantities greater than 500 to 5,000 kg (100 to 11,000 lb), the quantity-distance criteria in the table only apply to IBD exposures. Use 50 percent of the IBD criteria for PTRD exposures with a 91 meter (300 foot) minimum distance (out the front or rear) or a 120 meter (400 foot) minimum distance (off the sides). Use 35 percent of the IBD criteria for ILD exposures with a 91 meter (300 foot) minimum distance (out the front and rear) or a 120 meter (400 foot) minimum distance (off the sides).

**Table 9-5**  
**Quantity-distance for asset preservation at airfields**

From Airfield PESs to	Minimum separation distance	Asset preservation distance
Manned functions not related to the combat mission	IBD	IBD
Base boundaries without an easement unless manifestly unsuitable	IBD	IBD
Crew support and billeting areas	IBD	IBD
Central airfield support facilities	ILD	Note
Functions directly related to the explosives mission (manned)	ILD	Note
Flight line fire and rescue services	ILD	Note
Manned munitions operating locations (assembly, maintenance, refurbishment, and so forth)	IMD	Note
Any other explosives loaded aircraft or CAPA	IMD	Note
Flight line Munitions Holding Area	IMD	Note
Military use runways and taxiways	D=1.8Q <sup>1/3</sup> /K4.5	Note

Legend for Table 9-5:

For HD 1.1 material apply  $D=(9.5Q^{1/3})/(12Q^{1/3})=(K24/K30)$  separation.

For HD 1.2, 1.3, or 1.4 use PTRD from the appropriate chapter 8 table.

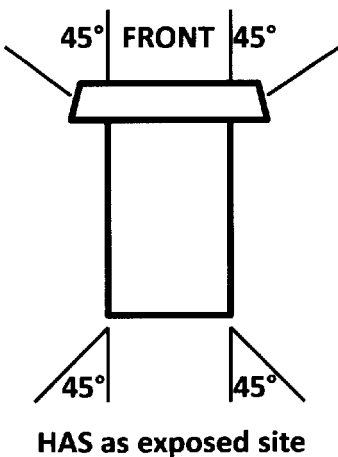

Figure 9-2. Hardened aircraft shelter as an exposed site

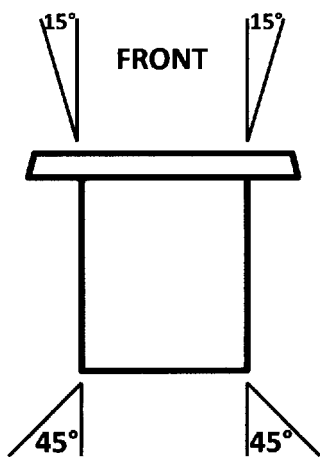

Figure 9-3. Hardened aircraft shelter as a potential explosion site

### 9-17. Static missile battery separation

To ensure optimal effectiveness offensive and defense missile batteries must often be deployed in the proximity of other explosives operations such as field storage or flight lines in a static (non-mobile role). The following criteria apply to deployed static missile batteries (for example, Patriots, Hawks and Rolands) and associated support functions.

*a.* IMD of  $D=4.4Q^{1/3}$  (K11) shall be maintained between missile launchers, reloads and other munitions storage locations to include parked explosives loaded aircraft.

*b.* Missile batteries deployed within the IBD clear zone of munitions storage areas may be sited at  $D=7.1Q^{1/3}$  (K18) to manned functions considered related to area explosives operations. Likewise, missile batteries deployed in the clear zone of flight line operations may be sited at  $D=7.1Q^{1/3}$  (K18) to manned flight line facilities.

*c.* Those functions solely providing support to static missile units, such as motor pools, may be sited at  $D=7.1Q^{1/3}$  (K18) to batteries and other explosives activities when the missile battery is located in those areas. For asset preservation, use PTRD.



d. No separation is required between missile batteries and the security forces structures exclusive supporting them.

### **9–18. Separation from fuel**

- a. Bulk fuel storage (More than 18,900 liters (5,000 gallons)). Apply distances as required in chapter 8.
- b. Operational storage (1,900 to 18,900 liters (501 to 5,000 gallons)). Ammunition and explosives shall be separated from operational fuel storage by at least 30 meters (100 ft). Fuel should be located downhill and diked to contain a possible fuel spill.
- c. Tactical Storage (1,890 liters (500 gallons) or less). Tactical fuel supplies shall be separated from ammunition and explosives by at least 15 meters (50 feet). Fuel should be located downhill and diked to contain a possible fuel spill.

## **Chapter 10 Wartime Operations**

### **10–1. General requirements**

a. This chapter provides guidance for the safe handling, transportation, and storage of ammunition during wartime and contingency operations. This guidance provides options, based on the acceptance of ever increasing degrees of risk, to the commander faced with various and fluctuating battlefield hazards. It may be used in developing battle doctrine and integrated into contingency and combat operations planning.

b. The provisions of this chapter apply when forces are engaged in combat operations.

c. Several fundamental concepts govern the relaxation of peacetime explosives safety standards during combat and contingency operations and the acceptance of added risks—

(1) Whenever and wherever possible, the peacetime explosives safety standards enumerated in this pamphlet should be followed. Only after assessing the risks of relaxation against the mission-imposed parameters should the less restrictive guidance of this chapter be implemented. This chapter provides operational flexibility not available in other parts of this pamphlet. The use of asset preservation criteria contained in this chapter is intended to maintain mission capability; however, these reduced levels of protection may impair or delay mission capability in the event of an explosives accident. This chapter's explosives safety QD standards include the following two levels of protection:

(a) *Asset preservation distance.* The distance that prevents propagation or reaction between PESs. (Assets at the exposed site (exposed site) are expected to be usable following an incident.) See table 10–3 for specific distances.

(b) *Minimum separation distance.* The distance that prevents prompt propagation; however, late time propagation of reactions between PESs is possible (mission capability will likely be impaired). See table 10–3 for specific distances.

(2) Where QD considerations must be relaxed, preventing propagation and preserving personnel, military equipment, and ammunition should be paramount. In some situations that do not meet the specific requirement, equivalent protection can be provided by the use of protective construction or by restructuring the operation. Situations where equivalent protection is provided must be supported by analysis and approved by the appropriate level of command. Equivalent protection that meets the regulatory requirements is not considered a deviation from this pamphlet.

(3) Tactical situations that are not covered by explosives safety regulations should be managed using the Army risk management process. Commanders should identify the hazards associated with the operation, assess these hazards, develop controls and make a decisions based on the analysis and lastly, supervise and evaluate the operation and controls.

(4) The third factor in QD explosives safety calculations is time. The degree to which standards are relaxed should be directly related to the duration of the exposure. Relaxation of standards for 24 hours involves less risk than relaxation for 48 hours.

(5) The acceptance of a high degree of explosives safety risk depends on the competing hazards of the battlefield. The risk of an explosives accident may be far outbalanced by more imminent battlefield hazards as ammunition approaches the forward line of own troops (FLOT).

(6) Ammunition logistical considerations and war fighting requirements should take precedence over compatibility in the mixing and grouping of ammunition items.

(7) Hazard Class/Division 1.2 ammunition should be treated as HD 1.1. When it becomes impractical to manage ammunition by hazard class, all ammunition, except identifiable HD 1.4, should be treated as HD 1.1. All captured ammunition, mixed ammunition, and unserviceable or unknown ammunition will be treated as HD 1.1.

d. When handling ammunition in the field, the following general principles apply:

(1) Soldiers controlling or supervising the handling of ammunition must observe safety precautions. Every effort will be made to ensure that skilled and knowledgeable personnel are in charge of ammunition operations.

(2) In field storage, ammunition should be distributed in such a way that an incident will not cause the total stock of any one type of ammunition to be lost.

(3) Ammunition will be dispersed to minimize loss in the event of fire, accidental explosion, or enemy action.

(4) Fire fighting precautions must be taken and firefighting equipment must be serviceable. All fires will be fought immediately without special order (see para 10–2*d*).

(5) Ammunition of unknown origin and captured ammunition will be examined, evaluated, and classified by qualified personnel and stored in a designated collection point (see para 10–2*c*).

(6) The existing infrastructure and terrain features (for example, buildings, barns, forests, barriers, and so forth) will be used to prevent propagation and to protect personnel and material from the effects of an explosion. Dry water courses will not be used during anticipated periods of heavy rain.

(7) Ammunition containing WP will be stored and transported in an upright position if ammunition surface temperatures are expected to exceed 111 degrees F.

(8) In any given field situation, all measures must be taken to minimize the risk to personnel, material, and ammunition.

(9) Provisions must be made to evaluate and, if necessary, segregate damaged ammunition.

(10) Provisions should be made, particularly for contingency operations of expected short duration, to save and segregate packing material to be reused to turn in safely and transport unused ammunition.

## **10–2. Theater and corps ammunition storage areas**

### *a. Quantity-distance.*

(1) Where the local situation allows, the peacetime QD specified in chapters 8 and 17 should be followed. This level of protection limits the risk to the civilian and unrelated military population from death or serious injury from blast overpressure and fragments due to an explosion, protects vital facilities from serious damage, and protects ammunition from propagation.

(2) Where the local situation does not allow for this level of external protection, the internal protection should be maintained. Any reduction in either internal or external distances increases the risk to adjacent facilities and other ammunition locations. Stacks of ammunition should be stored at the magazine distances specified in chapters 8 and 17. This level provides reasonable protection against propagation but risks the total destruction of exposed buildings and aircraft as well as death or serious injury to exposed personnel. (Every effort should be made to identify and protect facilities with dense population, such as hospitals, military facilities, headquarters, billeting and messing facilities, and POL storage, vital to the accomplishment of the mission.)

(3) Where existing ammunition storage sites are to be converted to wartime use, the ammunition storage license (see chap 5) lists the maximum NEW for which these sites will provide the level of protection described in (2), above.

(4) Where specific unimproved locations have been identified for use as wartime/contingency ammunition storage sites, Commands and DRUs may wish to develop ammunition storage licenses, providing the levels of protection described in paragraphs (1) and (2), above, and integrate these licenses into war plans.

(5) Permanent or contingency facilities with a designated wartime ammunition mission, such as ports, must integrate explosives safety QD guidance into war plans.

*b. Compatibility.* If at all practical, ammunition compatibility (see table 10–1) should be maintained during bulk storage.

(1) Compatibility does not apply to CCL's.

(2) Components of complete rounds may be stored together, for example, fuzes, projectiles, propelling charges, and primers.

(3) Blasting caps which are not in original packing configuration present a unique hazard and should be separated from other ammunition by sandbags or other suitable material to prevent line-of-site exposure.

(4) Logistical considerations and combat requirements take precedence over compatibility considerations.

### *c. Storage considerations.*

(1) Serviceable NATO standard ammunition, which has an assigned HD and storage compatibility group, will be stored in the same manner as U.S. ammunition.

(2) Unserviceable ammunition, regardless of the nation of origin, will be segregated from serviceable war reserve ammunition and appropriately tagged to prevent unintentional use.

(3) Captured ammunition, regardless of nation of origin, will be segregated in a designated collection point and separated from war reserve ammunition using HD 1.1 distances. Following examination, evaluation, and classification by qualified personnel, it may be assigned a temporary HD and CG, if necessary, by analogy to U.S. ammunition items.

*d. Firefighting.* All fires in the vicinity of ammunition should be fought until the stacks of explosives or ammunition become involved in the fire. Because evacuation to IBD will not always be practical, seek protection from an imminent explosion in trenches and behind natural earthen barricades.

## **10–3. Storage at the ammunition supply points and ammunition transfer points**

*a.* The same principles of explosives safety in ammunition storage and handling apply at ASPs and ammunition transfer points (ATPs) as at theater and corps ammunition storage areas.

b. The principal explosives safety objectives should be the prevention of propagation and the dispersion of ammunition to minimize loss in case of fire, accidental explosion, or enemy action.

c. Since more risk is assumed at an ASP or ATP, field storage (see para 10–5) should be considered a routine storage option. Ammunition may be stored, according to logistical considerations and combat requirements, using either paragraph 10–2 or paragraph 10–5.

d. Where real estate constraints do not permit the separation distances specified in table 10–2, modular storage (see para 10–7) should be constructed.

#### **10–4. Short-term ammunition transfer points storage**

a. At ATPs where ammunition is stored for periods of 3 days or less, ammunition will be positioned to fulfill logistical and administrative requirements.

b. Wherever possible, field storage (see para 10–5) or modular storage (see para 10–7) should be used.

c. All explosives safety requirements must be observed.

#### **10–5. Field storage and handling areas**

a. *General.* Field storage and handling areas shall be sited in accordance with table 10–2. Use separation distances from the various Chapter 8 distance tables for the type and quantity of explosives involved with the potential explosion site.

b. *Field storage and handling area layouts.* Field storage and handling areas may consist of all or only some of the following areas:

(1) *Storage sections.* A location where AE is stored. The principal objective of the field storage concept is the dispersion of ammunition to minimize loss in case of fire, accidental explosion, or enemy action. Each type of ammunition should be stored in multiple, widely separated storage sections to prevent the loss of any one section from seriously handicapping military operations by the loss of the entire supply of an item. Storage section separation distances are designed to prevent simultaneous detonation from adjacent storage sections.

(2) *Ammunition and explosives staging area.* The AE staging areas are normally used as a holding area for outgoing AE and for ready access to combat aircraft loading areas.

(3) *Captured enemy ammunition area.* A separate area shall be provided for the CEA. Captured enemy munitions that cannot be identified shall be treated as Hazard Division 1.1.

(4) *Ammunition and explosives operations area.* An area used for operations such as minor maintenance and repair of AE or their containers, surveillance, segregation, or weapons assembly.

(5) *Ammunition and explosives destruction area.* A demolition area used for the destruction of AE and may consist of a burning area or a demolition area.

(6) *Sling out area.* An area used for the movement of AE by rotary wing aircraft.

(7) *Administration and billeting areas.* Inhabited locations not directly related to the daily operations of the field storage area.

(8) *Boundaries.* The clear zone surrounding the field storage area, bound by the IBD arcs. No unrelated, occupied structures are permitted within these arcs.

(9) *Manned non-explosives support facilities.* Facilities that directly support AE operations, such as field offices and AE support equipment maintenance facilities.

(10) *Unmanned non-explosives support facilities.* Unmanned locations that support AE operations such as forklift charging stations, dunnage storage, and buildings that store inert materials. A minimum 15-meter (50-foot) separation distance shall be maintained from these locations to PESs.

c. *Storage in existing facilities.* Ammunition and explosives may be stored in caves and tunnels as prescribed in Chapter 8.

d. *Barricades and revetments.* The construction of and use of barricades and revetments shall be per chapter 8.

e. *Commercial Intermodal Containers (CIC).* Containers used for transporting ammunition may be used for ammunition and explosives storage and shall be sited as above-ground magazines. The containers may be sited individually or by groups.

f. *Segregation of ammunition and explosives.* Compatibility group will segregate ammunition and explosives unless grouped together as CCLs.

#### **10–6. Transportation within the theater of operations**

a. When selecting vehicles to transport ammunition, if vehicles meeting peacetime standards are not available, choose vehicles which do not present a fire hazard. That is, vehicles with leaks, sticking brakes, holes in the floor of the cargo area, or exhaust problems should be avoided.

b. Ammunition loads must be secured to prevent shifting and loss of the load during transport.

c. Vehicles should be equipped with two fire extinguishers to allow for fighting vehicle fires en route.

d. Considerations of compatibility will not apply to the transport of CCLs or other configurations being transported

in the direction of the FLOT. However, when mission permits, consideration should be given to transporting CGs “H,” “J,” “K,” and “L” on separate vehicles.

#### **10–7. Modular storage**

*a.* In a combat zone where insufficient real estate, limited security or operational requirements are determining factors, the modular system of storage may be employed. This system does not provide the degree of protection to personnel or ammunition stocks afforded by the QD requirements previously described in this chapter and should be implemented only as a last resort.

*b.* The decision to use the modular system must be made with full realization of its advantages and disadvantages over other field storage systems.

(1) The advantages include—

*(a)* Greatly reduced real estate requirements.

*(b)* Greatly improved security with comparable forces.

*(c)* Reduced transportation requirements within the ammunition area.

*(d)* Greatly reduced road net requirements.

*(e)* Reduced vulnerability to direct fire on ammunition stocks because of the smaller area and use of barricades.

(2) The disadvantages include—

*(a)* The possibility of explosion or fire in one cell starting fire in other cells because of heat generation or indirect fragment dispersion.

*(b)* Increased vulnerability to enemy indirect fire and air-dropped bombs because of concentration of stocks.

*(c)* Additional engineer support required for initial construction of modules as opposed to that required for unbaricaded open storage.

*c.* A module is a barricaded area composed of a series of connected cells separated from each other by barricades. In wartime operations the following exceptions apply:

(1) There is no restriction on the type of ammunition authorized for modular storage.

(2) Mixing ammunition stocks in modular storage is authorized.

#### **10–8. Policy for captured enemy ammunition and explosives**

*a.* The CEA pose a significant risk to personnel, military equipment and ammunition. While there are many unknowns associated with CEA, such as NEW, hazard compatibility, and fuzing mechanisms, the use of U.S. munitions and explosives safety procedures for CEA handling, transportation, storage, and disposal will significantly enhance the safety of these operations.

*b.* Units that discover or capture quantities of stored or cached enemy ammunition and explosives during the course of their operations will ensure that this CEA is properly, safely, and securely handled, transported, stored, or destroyed as necessary to protect personnel and assets.

*c.* Operations involving CEA will be assessed using the Army composite risk management process to provide the maximum possible safety to personnel and property from the damaging effects of an unintentional detonation and to ensure that only the minimum number of persons are exposed to the minimum quantity of CEA for the minimum time, consistent with safe and efficient operations.

*d.* Personnel conducting CEA-related operations shall be:

(1) trained in the characteristics, hazards, and hazard controls of CEA and in safety policy and standards for CEA and CEA operations;

(2) briefed on all pertinent procedures for the safe handling and/or destruction of CEA prior to performing their specific assigned duties.

*e.* Operations involving CEA will follow DOD and Army explosives safety standards and procedures, to the maximum extent practicable. If these standards and procedures cannot be met, document the reason they cannot be met, the actions to be taken to mitigate the risks associated with the operation being performed, and the name and rank of the official approving the deviation.

*f.* Wartime operations may necessitate the acceptance of higher risks than would normally be acceptable during other operations. The handling, transportation, storage, and disposal of CEA will be managed differently, as outlined in paragraph 10–9.

*g.* The chain of command is responsible for continually evaluating compliance with this policy and the attached standards and procedures for safe handling, transportation, storage, and disposal of CEA to ensure the safety of personnel and assets.

#### **10–9. Standards and procedures for safe handling, transportation, storage, and disposal of captured enemy ammunition**

*a. Wartime and periods of active hostilities.* Commanders at all levels must provide the maximum possible protection to personnel and property from the damaging effects of an unintentional detonation. For maneuvers

involving CEA this is accomplished by ensuring the minimum number of persons will be exposed to the minimum quantity of CEA for the minimum time, consistent with safe and efficient operations.

(1) *Discovery, assessment, and disposition.*

(a) When CEA is encountered during combat operations, the senior commander must determine, based on safety, security, and intelligence considerations, whether it will be destroyed, moved, or held in place.

(b) The capturing unit will immediately secure the site and request that qualified personnel (such as, EOD) inspect the CEA as soon as possible to determine its condition, type, serviceability, caliber, and storage compatibility group. Sandbag barricades can be built where practicable and when needed, near (but not touching) the CEA, to provide fragment protection in the event of an accidental detonation prior to the arrival of EOD personnel.

(c) Any special or unusual characteristics that may be of interest to technical intelligence personnel should be noted and reported through appropriate channels. Training Circular 20–32–5, Commander's Reference Guide, Land Mine and Explosive Hazards (Iraq), 13 February 2003, contains a nine-point format for reporting UXO that should be adapted and used for reporting CEA. When units are not sure as to the CEA's characteristics, the CEA should not be moved or destroyed because the unknown hazards (for example, the toxic and fire hazards associated with liquid propellant, radiological hazards, the hazards associated with chemical or biological warfare material, and so forth) may result in a catastrophic incident.

(d) The CEA that has been determined to be hazardous should be separated from serviceable CEA and disposed of as soon as possible. The CEA determined to be unsafe for handling and/or transport will normally be immediately destroyed in place or in the general vicinity of discovery by EOD personnel who will ensure that adequate protective measures (such as, separation distances, use of barricades) are taken.

(e) The senior commander is responsible for the security of the CEA until final disposition.

(2) *Training and qualification.*

(a) Only those personnel trained and authorized to conduct CEA operations may handle, assess, demilitarize or dispose of CEA. Furthermore, personnel conducting CEA operations shall be under the direct supervision of explosives safety qualified personnel (such as, EOD or QASAS) unless explosives safety qualified personnel have determined and documented that the risk associated with the CEA operation is acceptable. When EOD or QASAS personnel are not available, Special Operations Forces (SOF) Commanders (0–5 and above) may authorize SOF engineer sergeants (PMOS 18C) to survey and segregate CEA, until EOD or QASAS become available. The authorization may include the destruction of CEA.

(b) Theater EOD assets will be used to the fullest extent possible to assist in the survey, segregation, and destruction of CEA. Maximum use of EOD and familiarity training about foreign munitions (for example, ammunition and explosives) should be made to familiarize theater forces with specific types and aspects of foreign munitions in their areas of operation.

(3) *Transportation, holding, and storage of CEA.*

(a) When CEA is to be transported or placed in holding or storage, the Army risk management process will be used to identify and mitigate associated risks to provide the maximum possible protection to personnel and property from the damaging effects of an unintentional detonation of CEA.

(b) The CEA should be assessed to determine, if possible, the CG. Some CG present an increased hazard when stored together or incorrectly transported. Such CG must be segregated from conventional high explosive (HE) munitions and from each other. Munitions and CG requiring segregation from HE and each other are:

1. Munitions that contain WP (such as, Yugoslav 60mm Mortar, USSR 82mm Mortar, and USSR 122mm Projectile,) or other compounds that ignite spontaneously when exposed to air. Such munitions would be designated CG - H.

2. Munitions that contain flammable liquid or gel fill (such as, USSR, 80mm, FAE rocket and Egyptian FAE bomb). Such munitions would be designated CG - J.

3. Munitions that contain toxic chemical agent fill. Such munitions would be designated CG - K.

4. Unique, damaged or suspect munitions (such as, SA–2, ground to air missiles, ground to ground rockets or similar items that have liquid fuel rocket motors). Such munitions would be designated CG - L.

(c) When transporting CEA, other than small arms ammunition (.50 cal and below), the CEA should be placed in an unoccupied conveyance (generally a trailer). Consideration should be given to using an armored vehicle to tow the trailer to provide additional protection to personnel. If a trailer is unavailable, consult with higher command for guidance to minimize exposure.

(d) CEA must be secured, in some manner, to prevent both movement and its impact with other CEA during transport (for example, placing CEA on a bed of sand inside wooden boxes and then securing the boxes in the transport conveyance with strapping or dunnage). Consideration must be given to protecting exposed fuzes, primers, initiators and safety devices.

(e) Following transport of CEA, any change noted in the condition of CEA (such as, the discovery of a missing safety pin, explosives filler exudation, or other unusual conditions) will be reported to EOD personnel for a new assessment.

(f) The application of adequate explosives safety separation distances to CEA provides protection to personnel and materiel assets and helps commanders ensure that their combat capabilities are maintained. CEA will be separated from

exposed sites by distances prescribed in table 10–2 to protect personnel and assets from blast and fragments from an accidental detonation.

(g) U.S. Army units will only retain CEA for security, intelligence, Research, Development, Test, & Evaluation (RDTE), training, demilitarization or other purposes when authorized by the mission commander exercising overall operational control of the discovering unit's operations. Such CEA shall be clearly indicated as "Serviceable." Serviceable CEA will be stored in a separate area from U.S. ammunition per table 10–2. CEA will not be stored closer than PTRD.

(h) In the event of a lightning storm, personnel will evacuate to at least IBD from the CEA. In the event of a fire or explosion at a CEA storage area, personnel will evacuate to an area not closer than 4,000 feet but as far away as possible. Personnel will not re-enter the evacuation zone until EOD personnel have surveyed the area and declared it safe for re-entry.

b. Contingencies, Combat Operations, and Military Operations Other Than War. In addition to the Wartime and Periods of Active Hostilities CEA guidance in paragraph 10–9a, above, the following additional control measures apply:

(1) *Assessment.*

(a) The QASAS or other trained and certified explosives safety personnel (for example, UXO qualified personnel employed by or under contract with the U.S. Army) will inspect CEA as soon as possible at designated storage sites to determine its condition, type, and caliber. If EOD has not already assessed the safety of the item or if damage appears to have occurred in transit, an assessment of the safety of the CEA must be made prior to it being placed in storage.

(b) The NEW of CEA will be calculated using service publications on foreign munitions or by using the NEW of similar type and caliber munitions (DOD or foreign). For unknown munitions, the entire (gross) weight of the munitions will be used as the item NEW.

*Note.* (For foreign munitions, EOD personnel are normally the best source of NEW Information. A nonclassified source of NEW is the Iraq Ordnance Identification Guide prepared by the Naval EOD Technical Center, Indian head, MD).

(c) The NEW will be used to calculate separation distance for storage and disposal operations.

(2) *Holding and storage areas.*

(a) Qualified explosives safety personnel (such as, explosives safety specialists, QASAS, Ammunition Logistics Assistance Representatives (LARS), or EOD personnel) will provide safety guidance in establishing CEA storage and holding areas.

(b) Explosives licenses will be developed to establish allowable explosives limits prior to movement of CEA to a holding or storage area.

(c) If space is available, store CEA in multiple small stacks, properly segregated and separated. Such storage is preferable over a few large stacks.

(d) Fire prevention measures (separation from flammable and combustible material and use of firefighting equipment) will be employed and inspected on a regular basis.

(e) The process used to calculate safe separation distances is found in chapter 8.

(f) The CEA will be controlled and safeguarded in the same manner as that prescribed for DOD munitions of similar hazard classification and CG, security classification, and caliber or type (for example, CAT-I-like CEA will be handled as CAT I).

(g) When unserviceable CEA must be stored in the same storage facility as either serviceable CEA or DOD munitions, it will be clearly indicated as "Unserviceable" and physically separated (such as, in a sandbagged or other barricaded area).

(3) *Demilitarization and Disposal.*

(a) Only EOD or UXO qualified personnel employed by or under contract with the U.S. Army will be used to demilitarize or dispose of CEA.

(b) Destruction sites for CEA will be separated from other locations by intentional detonation distances specified in DODM 6055.09–M, chapter 9. Separation from the destruction point to the storage locations of CEA awaiting destruction will be a minimum of IL(U) distance, preferably by PTRD.

(4) *Site planning.* Locations used for storage or demolition of CEA where operations are expected to exceed 12 months require a DOD Explosives Safety Board (DDESB) approved site plan. Those facilities where operations are not expected to continue for more than 12 months require a risk assessment, which weighs the need for the facility against the potential effects of a mishap (such as, mission impact, loss of resources, turnaround times, and so forth), approved at the appropriate level in the chain of command (see DA Pam 385–30).

(5) *Deviation from standards and procedures.* When the tactical situation dictates deviation from these standards and procedures, the senior maneuver commander will apply the Army risk management process and protect personnel and assets to the maximum degree possible.

## **10–10. Ammunition turn-in at the cessation of hostilities**

a. At the cessation of hostilities the Army will commence transition to the peacetime provisions of this pamphlet.

Ammunition will be collected and stored at selected storage areas and turn-in points meeting the QD requirements of chapter 8. Where this is not practical, the guidance of this chapter may be used temporarily.

b. Segregation, inspection, field maintenance, destruction, and repackaging of turn-in ammunition will be accomplished in accordance with established logistics procedures. However, because of the increased risks associated with turn-in ammunition, these activities will take place in strict compliance with the separation distances specified in chapter 8.

c. Ammunition will not be offered for shipment to CONUS locations until a qualified military or civilian expert has certified in writing that the ammunition meets peacetime safety standards or equivalent for transport.

### 10-11. Emergency destruction of ammunition

When it becomes necessary to destroy stores of munitions to prevent them from falling to the enemy, care must be taken to ensure that assets otherwise not in danger of falling to the enemy are not destroyed by blast or fragments. Adjacent military units will be informed before the destruction takes place. See table 10-3 for quantity distance requirements using minimum separation and asset preservation criteria.

**Table 10-1**  
**Wartime compatibility chart**

Groups	A	B	C	D	E	F	G	H	J	K	L	N	S
A	X	X											X
B	X	X	X	X	X	X	X						X
C		X	X	X	X	X	X					X	X
D		X	X	X	X	X	X					X	X
E		X	X	X	X	X	X					X	X
F		X	X	X	X	X	X						X
G		X	X	X	X	X	X						X
H								X					X
J									X				X
K										X			
L													
N			X	X	X							X	X
S	X	X	X	X	X	X	X	X	X			X	X

**Table 10–2**  
**Quantity distance for field storage and handling areas**

From	Storage Sec-tions	AE Staging Area	Captured Enemy Ammunition Area	AE Operations Area	Sling Out Area	AE Destruction Area
<b>To</b>						
<b>Storage sections</b>	IMD	IMD	PTRD	IMD	IMD	Note 8
	Note 2	Note 2	PTRD	Note 2	Note 2	
<b>AE staging area</b>	IMD	IMD	PTRD	IMD	IMD	
	Note 2	Note 2	PTRD	Note 2	Note 2	
<b>Captured enemy ammunition area</b>	IMD	IMD	IMD	IMD	IMD	
	Note 2	Note 2	PTRD	Note 2	Note 2	
<b>AE operations area</b>	IMD	IMD	PTRD	IMD	IMD	
	Note 2	Note 2	PTRD	Note 2	Note 2	
<b>Sling out area</b>	NR	NR	PTRD	IMD	IMD	
	Note 2	Note 2	PTRD	Note 2	Note 2	
<b>Administrative and Billeting Area</b>	IBD	IBD	IBD	IBD	IBD	
	IBD	IBD	IBD	IBD	IBD	
<b>Boundaries</b>	IBD	IBD	IBD	IBD	IBD	
	IBD	IBD	IBD	IBD	IBD	
<b>Manned nonexplosive support facility</b>	ILD	ILD	IBD	ILD	ILD	
	Note 2	Note 2	IBD	Note 2	Note 2	
<b>Unmanned nonexplosive support facility</b>	NR	NR	PTRD	NR	NR	
	Note 2	Note 2	PTRD	Note 2	Note 2	
<b>AE destruction area</b>	Note 8					

Notes:

- <sup>1</sup> The distance criteria in the upper half of each row is the minimum separation distance in accordance with chapter 8.
- <sup>2</sup> The distance criteria in the lower half of each row are the asset preservation distance. For HD 1.1 material apply  $D=(9.5Q^{1/3})/(12Q^{1/3})=(K24/K30)$  separation. For HD 1.2, 1.3, or 1.4 apply PTRD from chapter 8 tables.
- <sup>3</sup> IMD=Intermagazine distance.
- <sup>4</sup> PTRD=Public traffic route distance (includes minimum fragment distance).
- <sup>5</sup> ILD=Intraline distance.
- <sup>6</sup> IBD=Inhabited building distance (includes minimum fragment distance).
- <sup>7</sup> NR=Not required.
- <sup>8</sup> In accordance with QD requirements of chapter 8.

**Table 10–3**  
**HD 1.1 quantity distance requirements using minimum separation and asset preservation criteria**

NEW in lbs.	Minimum separation distance	Asset preservation distance		NEW in lbs.	Minimum separation distance	Asset preservation distance
50	41	88		55,000	418	913
100	51	111		60,000	431	940
150	58	128		65,000	442	965
200	64	140		70,000	453	989
250	69	151		75,000	464	1,012
300	74	161		80,000	474	1,034



**Table 10-3**  
**HD 1.1 quantity distance requirements using minimum separation and asset preservation criteria—Continued**

350	78	169		85,000	484	1,055
400	81	177		90,000	493	1,076
500	87	190		95,000	502	1,095
600	93	202		100,000	511	1,114
700	98	213		105,000	519	1,132
800	102	223		110,000	527	1,150
900	106	232		115,000	535	1,167
1,000	110	240		120,000	543	1,184
1,250	118	259		125,000	550	1,200
1,500	126	275		130,000	557	1,216
2,000	139	302		135,000	564	1,231
2,500	149	326		140,000	571	1,246
3,000	159	346		145,000	578	1,261
3,500	167	364		150,000	584	1,275
4,000	175	381		155,000	591	1,289
4,500	182	396		160,000	597	1,303
5,000	188	410		165,000	603	1,316
6,000	200	436		170,000	609	1,330
7,000	210	459		175,000	615	1,342
8,000	220	480		180,000	621	1,355
9,000	229	499		185,000	627	1,368
10,000	237	517		190,000	632	1,380
12,500	255	557		195,000	638	1,392
15,000	271	592		200,000	643	1,404
17,500	286	623		205,000	649	1,415
20,000	299	651		210,000	654	1,427
22,500	311	678		220,000	664	1,449
25,000	322	702		225,000	669	1,460
30,000	342	746		230,000	674	1,470
35,000	360	785		235,000	679	1,481
40,000	376	821		240,000	684	1,491
45,000	391	854		245,000	688	1,502
50,000	405	884		250,000	693	1,512

## Chapter 11 Underground Storage

### 11-1. Underground storage

#### *a. Scope.*

(1) Underground storage facilities include natural caverns and below grade, excavated chambers, but criteria of this section also apply to any storage facility providing the overpressure confinement effects typically encountered in underground storage. Use criteria of this section only when the minimum distance from the perimeter of a storage area to an exterior surface exceeds  $0.25W^{1/3}$ . Otherwise use above ground siting criteria. This minimum distance most often, but not always, equals the thickness of the earth cover. This section addresses explosives safety criteria both with and without rupture of the earth cover.

(2) Expected ground shock, debris, and airblast hazards from an accidental explosion in an underground storage

facility depend on several variables, including the local geology and site specific parameters. These parameters vary significantly from facility to facility, so criteria listed here will likely be safety conservative for most geologies and configurations. Siting distances other than those listed may be used when validated by approved experimental or analytical results showing equivalent protection to that required.

(3) The QD siting requirements of this section may be determined from the applicable equations or by interpolating between the table and figure entries. No specific limitation on NEW applies to underground facilities or to individual chambers within facilities.

*b. Provisions.* The provisions of this section do not apply to storage in earth-covered magazines described elsewhere in this pamphlet.

### 11-2. Design of underground storage facilities

*a.* An underground storage facility may consist of a single chamber or a series of connected chambers. There may also be protective construction features in the facility. The chamber(s) may be either excavated or natural geological cavities. Figure 11-1 illustrates general concepts for several possible configurations of underground facilities.

*b.* Design of new underground storage facilities must take into account site conditions, storage requirements and operational needs. Once these are established, a design may be developed based on Corps of Engineers definitive drawing number DEF 421-80-04.

*c.* An underground storage site normally requires protection against lightning only for exposed or almost exposed parts. Metal and structural parts of the site that have less than 2 feet of earth cover should be protected as for an aboveground site. Lightning protection requirements must be considered on a site-specific basis.

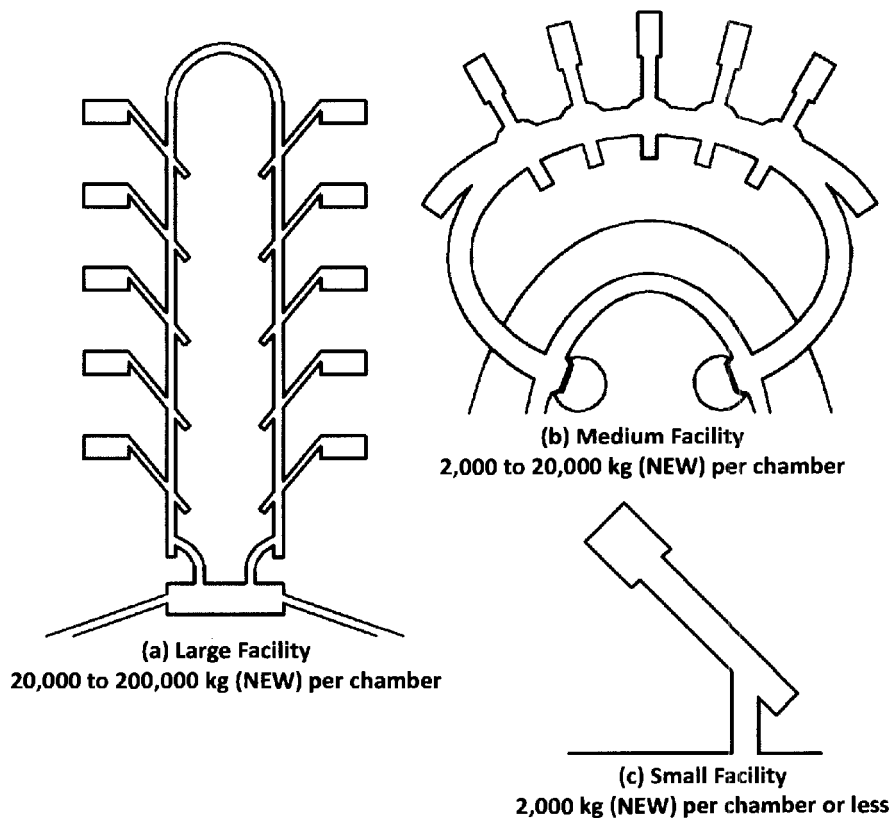

Figure 11-1. Typical underground facilities

### 11-3. Explosion effects in underground storage sites

a. Confinement caused by the very limited space in underground storage will cause very high pressures of prolonged duration from an accidental explosion. Blast waves and dynamic flow fields will travel at high velocity throughout the facility. Ground shocks will be produced, and breakup of the earth cover with attendant debris throw may occur.

b. Under conditions of heavy confinement and high loading density, HD 1.3 materials may, while either detonating or burning, produce intense gas pressures sufficient to rupture the earth cover and create a significant surface debris hazard.

c. An accidental explosion involving only HD 1.2 material will likely start a fire that may be sustained by burning packages and other ammunition. This may cause further explosions that become more frequent as the fires build and multiply, until everything in the site is destroyed. Results of these repeated explosions will depend on the type and quantity of munitions, the type of explosion produced, and the layout of the facility. Hazards created outside the underground facility will likely not be as severe as those produced by HD 1.1 or 1.3 materials.

### 11-4. Protection provided

The QD criteria listed here provide separation distances from stored ammunition and explosives to mitigate the hazards caused by ground shock, debris, or airblast. The required distance for a given quantity and storage condition is that corresponding to the dominant (farthest-reaching) hazard that is applicable to the exposure under consideration. It is therefore the largest of the distances determined to be necessary for protection against the individual effects considered in turn.

### 11-5. Chamber separation requirements

a. The chamber separation distance is the shortest distance (rock thickness) between two chambers. Minimum storage chamber separation distances are required to prevent or control the communication of explosions or fires between donor and acceptor chambers. There are three modes by which an explosion or fire can be communicated: by rock spall, by propagation through cracks or fissures, and by airblast or thermal effects traveling through connecting passages.

b. Prevention of damage by rock spall (HD 1.1 and 1.3). When an explosion occurs in an underground storage chamber, a shock wave is transmitted through the surrounding rock. The intensity of the shock decreases with distance.

(1) For small chamber separation distances, the shock may be strong enough to produce spalling of the rock walls in neighboring chambers. Spalled rock of sufficient energy may damage or initiate a detonation in impacted munitions.

(2) When no specific protective construction is used, the minimum chamber separation distance, ( $D_{cd}$ ), required to prevent hazardous spall effects is  $D_{cd}=2.5 W^{1/3}$  where  $D_{cd}$  is in feet and  $W$  is in pounds. Under no circumstances may this distance be less than 15 feet. The separation distances defined above apply to chamber loading densities up to 3.0 pounds per cubic foot and moderate to strong rock types.

(3) This loading density is the basis for values of  $D_{cd}$  listed in table 11-2.

(4) For greater loading densities in moderate to strong rock, the required separation distance is  $D_{cd}=5.0 W^{1/3}$ . For weak rock, at all loading densities, the separation distance is  $D_{cd}=3.5 W^{1/3}$ .

c. Prevention of propagation by rock spall (HD 1.1 and 1.3). If damage to stored munitions in adjacent chambers is considered acceptable by the ACOM, ASCC, or DRU, the chamber separation distance can be reduced to the distance required to prevent immediate explosion propagation by the impact of rock spall against the munitions. Propagation by rock spall is considered an immediate mode of propagation because time separations between donor and acceptor explosions may not be sufficient to prevent coalescence of blast waves.

(1) Unless analyses or experiments indicate otherwise, explosives weights subject to this mode must be added to other donor explosives weights to determine NEW.

(2) When no special protective construction is used, the separation distance,  $D_{cp}$ , to prevent propagation by spalled rock is  $D_{cp}=1.5 W^{1/3}$ , where  $D_{cp}$  is in feet and  $W$  is in pounds.

(3) When the acceptor chamber has protective construction to prevent spall and collapse (into the acceptor chamber) the separation distance to prevent propagation by impact of spalled rock is  $D_{cp}=0.75 W^{1/3}$  and where  $D_{cp}$  is in feet and  $W$  is in pounds. Separation distances,  $D_{cp}$  and  $D_{cd}$ , are listed in table 11-2. These distances are based on an explosive loading density of about 17 lb/ft<sup>3</sup>. The distances will likely be safety conservative for lower loading densities but the effects have not been quantified.

d. Prevention of propagation through cracks and fissures (HDs 1.1 and 1.3). Propagation between a donor and acceptor chamber has been observed to occur when natural, near horizontal jointing planes, cracks or fissures in the rock between the chambers are opened by the lifting force of the detonation pressure in the donor chamber.

(1) Prior to construction of a multi-chamber magazine, a careful site investigation must be made to ensure that such joints or fissures do not extend from one chamber location to an adjacent one.

(2) Should such defects be encountered during facility excavation, a reevaluation of the intended siting will be required.

*e.* Prevention of propagation through passageways (HDs 1.1 and 1.3). Flame and hot gas may cause delayed propagation. Time separations between the original donor event and the potential explosions of this mode will likely be sufficient to prevent coalescence of blast waves.

(1) Consequently, for purposes of QD siting, only the maximum credible explosives weight need be used to determine NEW.

(2) In order to protect assets, blast and fire resistant doors must be installed within multichambered facilities.

(3) Evaluations for required chamber separations due to this communication mode should be made on a site specific basis using procedures outlined in Corps of Engineers definitive drawing DEF 421-80-04.

*f.* For HDs 1.1 and 1.3 materials, chamber entrances at the ground surface, or entrances to branch tunnels off the same side of a main passageway, shall be separated by at least 15 feet. Entrances to branch tunnels off opposite sides of a main passageway shall be separated by at least twice the width of the main passageway.

*g.* Chambers containing only HDs 1.2 and 1.4 materials and separated by the minimum distances listed above may be used to the limits of their physical capacities unless the munitions are subject to special stacking or NEW restrictions.

*h.* When HD 1.2 or 1.4 materials are combined in underground storage with HD 1.1 or 1.3 materials, the propellant and explosive content of all items present shall be added to obtain NEW.

### **11-6. Chamber cover thickness**

The chamber cover thickness is the shortest distance between the natural rock surface at the chamber ceiling (or in some cases, a chamber wall) and the ground surface. The minimum cover thickness (critical cover thickness) required to prevent breaching of the chamber cover by a detonation is  $2.5.W^{1/3}$  for all types of rock.

### **11-7. External quantity-distance determinations**

*a. Hazard division material dependence.*

(1) *HDs 1.1 and 1.3 materials.* Distances shall be determined based on the total quantity of explosives, propellants, pyrotechnics, and incendiary materials in the individual chambers, unless the total quantity is subdivided to prevent rapid communication of an incident from one subdivision to another (see para 8-2 and table 8-1).

(a) All HD 1.1 and 1.3 material subject to involvement in a single incident will be assumed to contribute to the explosion yield as would an equal weight of TNT unless significant and validated differences exist in energy release per unit mass of the compositions involved.

(b) A connected chamber or cavern storage site containing HD 1.1 or 1.3 material shall be treated as a single chamber site, unless explosion communication is prevented by adequate subdivision or chamber separation.

(2) *HD 1.2 materials.* Except for primary fragments from openings to underground storage, external explosives safety hazards are not normally significant for HD 1.2 materials.

(a) The safe distance for both IBD and PTRD is the IBD in table 8-16 for locations within 10 degrees of the centerline of a tunnel opening. These default criteria apply only to those detonations which occur where a line-of-sight path exists from the detonation point to any portion of the tunnel opening.

(b) For detonations which do not have a line-of-sight path to the tunnel opening, or where the line of sight path is intercepted by a barricade beyond the opening, the IBD and PTRD hazard distances are zero.

(3) *HD 1.4 materials.* External explosives safety hazards are not normally significant for HD 1.4 materials. Accordingly, no external QD criteria apply.

*b. QD reference points.*

(1) Distances determined by blast or debris issuing from tunnel openings shall be the minimum distance measured from the openings to the nearest point of the location to be protected. Use extended centerlines of the openings as reference lines for directional effects.

(2) Distances determined for airblast and debris produced by breaching of the chamber cover shall be the minimum distance from an exterior point defined by chamber cover thickness, on the ground surface above the storage chamber to the nearest point of the location to be protected. For configurations where the storage chambers are not distinct from the access tunnel, the distance is the shortest distance from the tunnel roof directly above the charge to the surface.

(3) Distances determined for ground shock shall be the minimum distance measured from a point on the perimeter of the storage chamber to the location to be protected.

*c. Inhabited building distance (HD 1.1 and 1.3 materials).* The inhabited building distance provided shall be the largest of those distances required for protection against ground shock, debris, and airblast as defined below.

(1) *Ground shock.*

(a) For protection of residential buildings against significant structural damage by ground shock, the maximum particle velocity induced in the ground at the building site may not exceed the following values, which form the basis for the equations in paragraph 2, below: 2.4 ips in soil, 4.5 ips in weak rock, and 9.0 ips in strong rock.

(b) For sitings in moderately-strong to strong rock, with chamber loading densities of 3.0 lbs/ft<sup>3</sup> or less, the IBD for ground shock,  $D_{ig}$  is  $D_{ig}=5.8W^{1/3}$ , where  $D_{ig}$  is in feet and  $W$  is the explosive quantity in pounds.

(c) For higher loading densities in chambers sited in moderately strong to strong rock, and for all loading densities in other materials, the IBD for ground shock is  $D_{pg}=12.5f_g W^{4/9}$  (moderately strong to strong rock),  $D_{ig}=11.1f_g W^{4/9}$  (weak rock), and  $D_{ig}=2.1f_g W^{4/9}$  (soil). Values of  $D_{ig}/f_g$  are shown in table 11-4.

(d) The dimensionless, decoupling factor,  $f_g$  depends on chamber loading density,  $w$ , and is  $f_g=(4/15) W^{0.3}$ . Values of  $f_g$  are shown in table 11-7.

(e) Chamber loading density is the NEW (in pounds) divided by the volume of the storage chamber,  $V_c$  (in cubic feet).

(f) Alternate values for  $D_{ig}$  may be used when justified by site specific ground shock data.

(2) *Debris.*

(a) A minimum IBD of 1800 feet for debris throw from an opening shall apply within 10 degrees to either side of the centerline axis of that opening unless positive means are used to prevent or control the debris throw.

(b) Distances required for protection of inhabited areas against the effects of debris thrown from breaching of the cover material over a detonation,  $D_{id}$  depend on the thickness of the cover,  $C$ , over the storage chamber.

1. The possibility of damage from a surface breach need not be considered for chamber cover thicknesses greater than the critical value,  $C_c$ , of  $2.5W^{1/3}$ .

2. If the cover thickness is less than  $C_c$ , the distance,  $D_{id}$ , will be calculated from  $D_{id}=f_d f_c W^{0.41}$ , where  $f_d=0.6W^{0.18}$ , and  $f_c$  is a constant related to the type of rock around the storage chamber.

(c) Values of  $D_{id}/f_d$ , for moderately strong to strong rock, and for weak rock, are listed in tables 11-4 and 11-5. Values of  $f_c$  are shown graphically in figure 11-3. Values for the decoupling factors  $f_g$  and  $f_c$  are listed in table 11-6.

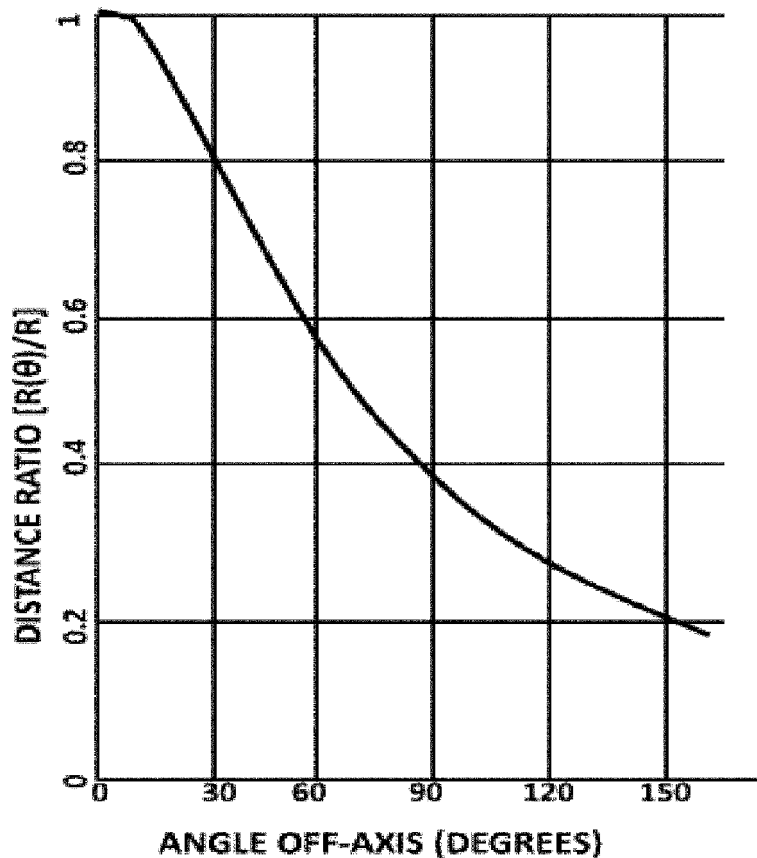

Figure 11-2. Constant pressure contour

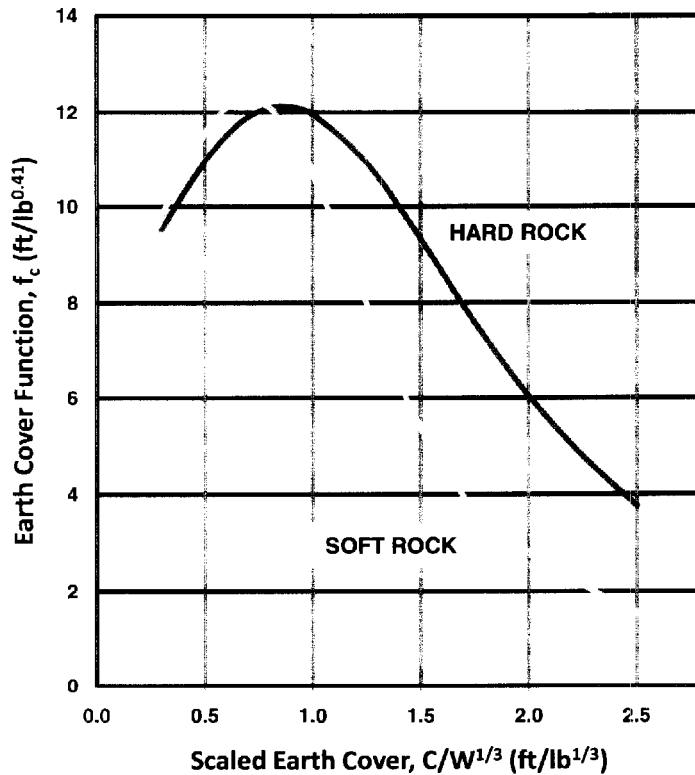

Figure 11-3. Debris dispersal functions

(d) Special features may be incorporated in the design of underground facilities to reduce the IBD for debris ejected through tunnel openings.

1. Debris traps are pockets excavated in the rock at or beyond the end of sections of tunnel, designed to catch debris from a storage chamber detonation. Debris traps should be at least 20 percent wider and 10 percent taller than the tunnel leading to the trap, with a depth measured along the shortest wall of at least one tunnel diameter.

2. Expansion chambers are large rooms located between the storage chamber(s) and the tunnel entrance(s), having a cross-section area at least three times as great as that of the largest tunnel intersecting the expansion chamber, and a length that is at least as great as the expansion chamber width. Expansion chambers are very effective in entrapping debris, as long as the tunnels entering and exiting the chambers are either offset in axial alignment by at least two tunnel widths, or enter and exit the chambers in directions that differ by at least 45 degrees.

3. Portal barricades provide a means of reducing or eliminating debris hazards by obstructing the path of the debris as it exits the tunnel. Construction and location requirements for barricades are contained in paragraph 16-25.

4. High-pressure closures are large blocks constructed of concrete or other materials that can obstruct or greatly reduce the flow of blast effects and debris from an explosion, from or into a storage chamber. For chamber loading densities of 0.6 lb/ft<sup>3</sup> (10 kg/m<sup>3</sup>) or above, closure blocks will contain 40 percent or more of the explosion debris within the detonation chamber, provided that the block is designed to remain intact. If a closure block fails under the blast load, it will produce a volume of debris in addition to that from the chamber itself. However, since the block's mass and inertia are sufficient to greatly reduce the velocity of the primary debris, the effectiveness of other debris-mitigating features, such as debris traps, expansion chambers, and barricades is increased.

(e) Debris traps, and expansion chambers intended to entrap debris, must be designed to contain the full potential volume of debris, based on the maximum capacity of the largest storage chamber. Design specifications for debris traps, expansion chambers, closure blocks and portal barricades are given in Corps of Engineers definitive drawing number DEF 421-80-04. Use of a portal barricade in conjunction with any other of the other protective features listed above will lower the debris hazard to a level where QD considerations for debris will not be required.

(3) *Airblast.*

(a) An explosion in an underground storage chamber may produce external airblast from two sources; the exit of blast from existing openings (tunnel entrances, ventilation shafts, and so forth) and the rupture or breach of the chamber cover by the detonation. Required inhabited building distances are to be independently determined for each of these airblast sources, with the maximum IBD used for siting.

1. If the chamber cover thickness is less than the critical thickness,  $C$ , some amount of external airblast will be produced, depending on the cover thickness.

2. Use the following procedure to find IBD for airblast produced by breaching of the chamber cover: if  $C < 0.25W^{1/3}$ , use distance in table 8-4 (Note 3); if  $0.25W^{1/3} < C < 0.50W^{1/3}$ , use 1/2 of applicable K40-K50 distance if  $0.50W^{1/3} < C$ .

(b) Overpressure and debris hazards must be determined for each facility opening whose cross-sectional area is five percent or more of that of the largest opening. Calculated overpressures should be reduced by 12 percent when two or more openings of similar cross-sectional area exist.

(c) Distance versus overpressure along the centerline axis of a single opening is  $R=149.3D[(W/V_E)^{0.5}/P_{SO}]^{1/1.4}$ , where  $R$ =distance from opening (feet).

1. Use the minimum, robust cross-sectional area within five tunnel diameters of the opening to compute the effective hydraulic diameter  $D$ : effective hydraulic diameter that controls dynamic flow issuing from the opening (feet);

2. Compute  $D$ , using the minimum, robust cross-sectional area that is located within five tunnel diameters of the opening, as  $D=4A/P$ , where  $A$  is the cross-section and  $P$  is the perimeter: (1)  $P_{SO}$ =overpressure at distance  $R$ , in psi, (2)  $W$ =NEW of the MCE, in pounds, and (3)  $V_E$ =total volume engulfed by the blast wave front within the tunnel system at the time the wave front arrives at the point of interest, in  $ft^3$ .

(d) Distance versus overpressure off the centerline axis of the opening is  $R(\theta)=R(\theta=0)/(1 + (\theta/56)^2)^{1/1.4}$ , where  $R(\theta=0)$ =the distance along the centerline axis and  $\theta$ =the horizontal angle from the centerline (degrees).

(e) The above equations show that the distance providing protection from an overpressure exceeding  $P$  so depends on the hydraulic diameter, and the angle from centerline axis for the location of interest. Figure 11-2 shows the ratio of off-axis to on-axis distances.

(f) Find required IBD for airblast using the appropriate equations discussed above.

1. With the criteria that the total incident overpressure at IBD shall not exceed:

- a.  $P_{SO}=1.2$  psi for  $W < 100,000$  lbs,
- b.  $P_{SO}=44.57W^{0.314}$  psi for  $100,000 < W < 250,000$  lbs.
- c.  $P_{SO}=0.9$  psi for  $W < 250,000$  lbs.

2. For these overpressures, on-axis IBDs are—

- a.  $R=131.1D(W/V_E)^{1/2.8}$  for  $W < 100,000$  lbs.
- b.  $R=9.91 DW^{0.581}/V_E^{0.357}$  for  $100,000 < W < 250,000$  lbs.
- c.  $R=161.0D(W/V_E)^{1/2.8}$  for  $W < 250,000$  lbs.

3. Distances for IBD airblast protection may be determined from the equations listed above or from entries in tables 11-9 and 11-10.

(4) Airblast mitigation methods for reducing IBD. Special features that may be incorporated in underground storage facilities to reduce the airblast IBD include—

(a) *Facility layouts.* A single-chamber facility with a straight access tunnel leading from the chamber to the portal is commonly called a 'shotgun' magazine because the blast and debris are channeled to the external area as if fired from a long-barreled gun.

1. More complex facility layouts will provide some reductions in the exit pressures due to reflections of the explosive shock against the tunnel walls. The desired cumulative effect is to reduce the overpressure at the shock front to the point that the peak overpressure is produced by the detonation gas flow following the front. The detonation gas pressure decreases as the volume it occupies increases. Therefore, the peak overpressure produced at the tunnel opening will also decrease with an increase in the total volume of the tunnels and chambers that can be filled by the blast as it travels from the detonation source (such as, a storage chamber) to the opening, as given in the previous section.

2. Larger facilities will, therefore, produce greater reductions in the effective overpressure at the opening, which will, in turn, reduce the IBD. The IBD should be reduced by 10 percent when two or more openings of similar cross-sectional area exist.

(b) *Expansion chambers.* Expansion chambers are so-named because of the volume they provide for the expansion of the detonation gasses behind the shock front as it enters the chamber from a connecting tunnel. Some additional degradation of the peak pressure at the shock front occurs as the front expands into the chamber and reflects from the walls.

1. The principal benefit provided by an expansion chamber; however, is simply the added volume that decreases pressures.

2. Expansion chambers also have practical purposes. They may be used as loading/unloading chambers, providing

weather protection for the transfer of munitions from trucks to materials handling equipment prior to placement in storage chambers, or as turnaround areas for transport vehicles servicing facilities through a single entry passage.

(c) *Constrictions.* Constrictions are short lengths of tunnel whose cross sectional areas are reduced to one-half or less of the normal tunnel cross section.

1. The use of constrictions should be limited to locations within 5 tunnel diameters of the tunnel exit or to the entrances of storage chambers.

2. A constriction near the tunnel exit, where the overpressure has dropped near a minimum value in the tunnel, defines the hydraulic diameter to be used in calculating airblast IBD. The purpose of a constriction at a chamber entrance is to reduce the intrusion of airblast and thermal effects into the chamber from a detonation in an adjacent chamber. A constricted chamber entrance also reduces the area, and hence the total loading on a blast door installed to protect the chamber contents.

(d) *Portal barricades.* For most underground storage facilities, the airblast from a storage chamber detonation that exits a portal will be in the form of a shock wave. A barricade in front of the portal will reflect that portion of the shock wave moving directly outward from the portal, reducing pressures along the extended tunnel axis and increasing the pressures in the opposite direction, behind the portal. The result is a more circular IBD area centered at the portal. Since much of the blast is also reflected upward, the total IBD area is less than would occur without a barricade.

1. For cases where the blast must travel a large distance from the storage chamber to the portal, with several changes in direction along its path, the airblast exiting the portal may primarily consist of a strong, highly-directional gas flow. A barricade can deflect such a flow up to 90 degrees from the tunnel axis.

2. Whether the blast exiting the portal is shock or gas flow-dominated, the barricade must be located within certain minimum and maximum standoff distances to be effective.

3. Location and construction requirements for portal barricades are described in Corps of Engineers definitive drawing number DEF 421-80-04.

4. Portal barricades reduce IBD along the extended tunnel axis by 50 percent. The total IBD area is only slightly reduced, but will change to a circular area, half of which is behind the portal.

(e) *High-pressure closures.* High-pressure closures are large blocks constructed of concrete or other material that can obstruct or greatly reduce the flow of blast effects and debris from an explosion, from or into a storage chamber.

1. If used to provide complete protection to the contents of a chamber from an explosion in another chamber, the block must be designed to move from a normally-closed position to an open position to allow entry into the chamber. Blast doors are not required for this type of closure block.

2. If used to reduce QD by restricting the blast outflow from a chamber, the block must be designed to be rapidly driven from an open to a closed position by the detonation pressures in the chamber. While this type of block will provide some protection of chamber contents from an explosion in another chamber, blast doors must also be used to provide complete protection.

3. Tests have shown that a closure block with sufficient mass can obstruct the initial outflow of airblast from an explosion in a chamber to reduce pressures in the connecting tunnels by a factor of two or more, even when the block is destroyed. Blocks with sufficient strength to remain structurally intact can provide greater reductions. Since many variables influence the performance of a closing device, their design details must be developed on a site-specific basis.

4. A 50 percent reduction in IBD should be applied to a high-pressure closure block provided that the block is designed to remain intact in the event of an explosion. This reduction is applicable for loading densities of 0.625 lb/ft<sup>3</sup> or higher.

5. For loading densities lower than 0.625 lb/ft<sup>3</sup>, reductions may be calculated by the formula  $y(\text{percent}) = 50 \log_{10}(16.02w)$ , where  $y$  = the percent reduction in IBD and  $w$  = loading density in lb/ft<sup>3</sup>.

6. Closure block design criteria are found in Corps of Engineers definitive design drawing number DEF 421-80-04.

**Table 11-1**  
**External quantity-distance determinations for HD 1.1 and 1.3 materials**

	Ground Shock	Debris	Airblast
1. PTRD	QD is 60 percent of IBD for ground shock.	QD is 60 percent of IBD for debris.	QD is 60 percent of IBD for airblast.



**Table 11-1**  
**External quantity-distance determinations for HD 1.1 and 1.3 materials—Continued**

<p><b>2. ILD</b></p>	<p>QD criteria for ground shock do not apply.</p>	<p>For locations within 10 degrees of the centerline of a tunnel opening, site intraline facilities at IBD for debris issuing from the opening, calculated as directed in paragraph 11-7g(3)(b), above. QD criteria for debris are not applicable for locations greater than 10 degrees from the centerline axis of an opening.</p>	<p>Overpressure at barricaded and unbarricaded ILD shall not exceed 12 and 3.5 psi, respectively.</p>
<p><b>3. Distance to above-ground magazines</b></p>	<p>QD criteria for ground shock do not apply.</p>	<p>QD criteria for surface debris do not apply. For locations within 10 degrees of the centerline of an opening, site aboveground magazines at IBD for debris issuing from the opening calculated as directed in paragraph 11-7g(3)(b), above.</p>	<p>Overpressure at barricaded and unbarricaded aboveground magazine distance shall not exceed 27 and 8 psi, respectively.</p>
<p><b>4. Distance to earth-covered aboveground magazines</b></p>	<p>QD criteria for ground shock do not apply.</p>	<p>QD criteria for surface debris do not apply. QD criteria for debris issuing from an opening do not apply if the magazine is oriented for side-on or rear-on exposures to the debris. Site earth-covered magazines that are located within 10 degrees of the centerline of an opening and oriented for a frontal debris exposure at IBD for that debris hazard calculated as directed in paragraph 11-7g(3)(b), above.</p>	<p>These site plans are based on the strength of the ECM under consideration and utilize side-on overpressures calculated using the formulas below:  1. <math>R=49.3 \times D_{HYD} \times ((W/V_E)^{0.5}/P_{SO})^{1/1.4}</math>  2. <math>R(q)=R(q=0)/(1 + (q/56)^2)^{1/1.4}</math> where: <math>R(q=0)</math> is the distance along the centerline axis, and <math>q</math> is the horizontal angle from the centerline (degrees).  a. Head-on exposure. 7-Bar ECM: Site where the side-on overpressure, <math>P_{SO}</math>, is 29 psi.  b. 3-Bar ECM: Site where the side-on overpressure, <math>P_{SO}</math>, is 16 psi. Undefined ECM: Site where the side-on overpressure, <math>P_{SO}</math>, is 3.5 psi  c. Other than Head-on Exposure. Site all ECMs where side-on overpressure, <math>P_{SO}</math>, is 45 psi.</p>

**Table 11-2**  
**Chamber separation**

Weight (lbs)	$D_{cp}(ft)$		$D_{cd}(ft)$	
	$1.5W^{1/3}$	$2.5W^{1/3}$	$3.5W^{1/3}$	$5.0W^{1/3}$
1,000	15	25	35	50
1,200	16	27	37	53
1,400	17	28	39	56
1,600	17.5	30	41	58
1,800	18	31	43	61
2,000	19	32	44	63
2,500	20.4	34	48	68
3,000	22	36	50	72
3,500	23	38	53	76
4,000	24	40	56	79
4,500	25	42	58	83
5,000	26	43	60	85
6,000	27	46	64	91
7,000	29	48	67	96
8,000	30	50	70	100
9,000	31	52	73	104
10,000	33	54	76	108
12,000	34	58	80	114
14,000	36	61	84	121

**Table 11-2  
Chamber separation—Continued**

16,000	38	63	88	126
18,000	39	66	92	131
20,000	41	68	95	136
25,000	44	74	102	146
30,000	47	78	109	155
35,000	49	82	114	164
40,000	51	86	120	171
45,000	53	89	124	178
50,000	55	93	129	184
60,000	59	98	137	196
70,000	62	103	144	206
80,000	65	108	151	215
90,000	67	112	157	224
100,000	70	116	162	232
120,000	74	124	173	247
140,000	78	130	182	260
160,000	81	136	190	271
180,000	85	142	198	282
200,000	88	147	205	292
250,000	94	158	220	315
300,000	100	168	234	335
350,000	106	177	247	352
400,000	111	185	258	368
450,000	115	192	268	383
500,000	119	199	278	397
600,000	127	211	295	422
700,000	133	222	311	444
800,000	139	232	325	464
900,000	145	242	338	483
1,000,000	150	250	350	500

**Table 11-3  
Distance to protect against ground shock**

Weight (lbs)	$D_{ig}/f_g$			
	$2.1W^{4/9}$	$11.1W^{4/9}$	$12.5W^{4/9}$	$5.8W^{1/3}$
1,000	45	239	269	58
1,200	49	259	292	62
1,400	53	278	313	65
1,600	56	295	332	68
1,800	59	311	350	71
2,000	62	325	366	73
2,500	68	359	405	79
3,000	74	390	439	84

**Table 11-3**  
**Distance to protect against ground shock—Continued**

3,500	79	417	470	88
4,000	84	443	499	92
4,500	88	467	525	96
5,000	93	489	551	99
6,000	100	530	597	105
7,000	107	568	640	111
8,000	114	603	679	116
9,000	120	635	715	121
10,000	126	665	749	125
12,000	137	722	813	133
14,000	146	773	870	140
16,000	155	820	923	146
18,000	163	864	973	152
20,000	171	906	1,202	157
25,000	189	1,000	1,126	170
30,000	205	1,084	1,221	180
35,000	220	1,161	1,308	190
40,000	233	1,232	1,388	198
45,000	246	1,298	1,462	206
50,000	257	1,361	1,532	214
60,000	279	1,476	1,662	227
70,000	299	1,580	1,779	239
80,000	317	1,677	1,888	250
90,000	334	1,767	1,999	260
100,000	350	1,852	2,085	269
120,000	380	2,008	2,261	286
140,000	407	2,150	2,421	301
160,000	432	2,282	2,570	315
180,000	455	2,404	2,708	327
200,000	477	2,520	2,837	339
250,000	526	2,782	3,133	365
300,000	571	3,017	3,398	388
350,000	611	3,231	3,639	409
400,000	649	3,429	3,861	427
450,000	684	3,613	4,069	444
500,000	716	3,786	4,264	460
600,000	777	4,106	4,624	489
700,000	832	4,397	4,951	515
800,000	883	4,666	5,254	538
900,000	930	4,916	5,537	560

**Table 11-4**  
**Distance to protect against hard rock debris**

Weight (lbs)	$C/W^{1/3}$ (FT/LB <sup>1/3</sup> )							
	.3	.5	.7	.9	1.1	1.6	2.1	3
	$D_{id}/f_d$ (ft)							
1,000	163	180	200	205	195	145	92	62
1,200	170	195	215	220	210	155	98	67
1,400	185	210	230	235	225	165	105	72
1,600	195	220	240	250	240	175	110	76
1,800	205	230	250	260	250	180	115	79
2,000	210	240	260	270	260	190	120	83
2,500	230	260	290	300	290	210	135	91
3,000	250	290	310	320	310	225	145	98
3,500	270	300	330	340	330	240	155	105
4,000	280	320	350	360	350	250	160	110
4,500	300	340	370	380	360	260	170	115
5,000	310	350	380	400	380	280	175	120
6,000	330	380	410	430	410	300	190	130
7,000	350	400	440	460	440	320	205	140
8,000	370	430	470	480	460	330	215	145
9,000	390	450	490	500	480	350	225	155
10,000	410	470	520	520	500	370	235	160
12,000	440	500	560	560	540	400	250	175
14,000	470	540	580	600	580	420	270	185
16,000	500	560	620	640	620	440	290	195
18,000	520	600	640	680	640	470	300	205
20,000	540	620	680	700	680	490	310	215
25,000	600	680	740	760	740	540	340	235
30,000	640	740	800	820	800	580	370	250
35,000	680	780	860	880	840	620	390	270
40,000	720	820	900	940	900	640	420	285
45,000	760	860	940	980	940	680	440	295
50,000	800	900	980	1,000	980	700	460	310
60,000	860	980	1,050	1,100	1,050	760	490	335
70,000	920	1,050	1,150	1,150	1,100	820	520	355
80,000	960	1,100	1,200	1,250	1,200	860	560	375
90,000	1,000	1,150	1,250	1,300	1,250	900	580	395
100,000	1,050	1,200	1,300	1,350	1,300	940	600	410
120,000	1,150	1,300	1,400	1,450	1,400	1,000	660	445
140,000	1,200	1,400	1,500	1,550	1,500	1,100	700	475
160,000	1,300	1,450	1,600	1,650	1,600	1,150	740	500
180,000	1,350	1,550	1,650	1,750	1,650	1,200	780	525
200,000	1,400	1,600	1,750	1,800	1,750	1,250	800	550
250,000	1,550	1,750	1,900	2,000	1,900	1,350	880	600

**Table 11-4**  
**Distance to protect against hard rock debris—Continued**

<b>300,000</b>	1,650	1,900	2,050	2,150	2,100	1,500	960	645
<b>350,000</b>	1,750	2,000	2,200	2,250	2,200	1,600	1,000	690
<b>400,000</b>	1,850	2,100	2,300	2,400	2,300	1,650	1,050	725
<b>450,000</b>	1,950	2,200	2,450	2,500	2,400	1,750	1,100	765
<b>500,000</b>	2,050	2,300	2,500	2,600	2,500	1,800	1,150	800
<b>600,000</b>	2,200	2,500	2,700	2,800	2,700	1,950	1,250	860
<b>700,000</b>	2,350	2,700	2,900	3,000	2,900	2,100	1,350	915
<b>800,000</b>	2,450	2,800	3,100	3,200	3,100	2,200	1,400	965
<b>900,000</b>	2,600	3,000	3,200	3,300	3,200	2,300	1,500	1,015

**Table 11-5**  
**Distance to protect against soft rock debris**

Weight (lbs)	C/W <sup>1/3</sup> (FT/LB <sup>1/3</sup> )							
	.2	.6	.75	.9	1	1.5	1.75	2.5
	D <sub>id</sub> /f <sub>d</sub> (ft)							
<b>1,000</b>	165	200	207	198	184	91	62	30
<b>1,200</b>	177	216	223	213	199	98	67	32
<b>1,400</b>	189	230	238	227	212	105	72	34
<b>1,600</b>	200	243	251	240	224	110	76	36
<b>1,800</b>	210	255	264	252	235	116	79	38
<b>2,000</b>	219	266	275	263	245	121	83	40
<b>2,500</b>	240	292	302	288	268	133	91	43
<b>3,000</b>	258	314	325	311	289	143	98	47
<b>3,500</b>	275	335	346	331	308	152	104	50
<b>4,000</b>	291	354	366	350	336	161	110	53
<b>4,500</b>	305	371	384	367	342	169	116	55
<b>5,000</b>	319	388	401	383	357	176	121	58
<b>6,000</b>	343	418	432	413	384	190	130	62
<b>7,000</b>	366	445	460	440	409	202	139	66
<b>8,000</b>	386	470	486	464	433	214	147	70
<b>9,000</b>	405	493	510	487	454	224	154	74
<b>10,000</b>	423	515	532	509	474	234	161	77
<b>12,000</b>	456	555	574	548	511	252	173	83
<b>14,000</b>	486	591	611	584	544	269	184	88
<b>16,000</b>	513	624	645	617	575	184	195	93
<b>18,000</b>	539	655	677	648	603	298	204	98
<b>20,000</b>	562	684	707	676	630	311	213	102
<b>25,000</b>	616	750	775	714	690	341	234	112
<b>30,000</b>	664	808	835	798	744	367	252	120
<b>35,000</b>	707	861	890	851	792	391	268	128
<b>40,000</b>	747	909	940	898	837	413	283	136
<b>45,000</b>	784	954	986	943	878	434	297	142

**Table 11-5**  
**Distance to protect against soft rock debris—Continued**

<b>50,000</b>	819	996	1,030	985	917	453	311	148
<b>60,000</b>	882	1,074	1,110	1,061	988	488	335	160
<b>70,000</b>	940	1,144	1,182	1,130	1,053	520	357	170
<b>80,000</b>	993	1,208	1,249	1,194	1,112	549	377	180
<b>90,000</b>	1,042	1,268	1,311	1,253	1,167	576	395	189
<b>100,000</b>	1,088	1,324	1,368	1,308	1,218	602	413	197
<b>120,000</b>	1,172	1,426	1,475	1,410	1,313	648	445	213
<b>140,000</b>	1,249	1,520	1,571	1,502	1,399	691	474	226
<b>160,000</b>	1,319	1,605	1,659	1,586	1,477	730	500	239
<b>180,000</b>	1,384	1,684	1,741	1,665	1,550	766	525	251
<b>200,000</b>	1,445	1,759	1,818	1,738	1,619	800	548	262
<b>250,000</b>	1,584	2,927	1,992	1,905	1,774	876	601	287
<b>300,000</b>	1,707	2,077	2,147	2,052	1,911	944	648	310
<b>350,000</b>	1,818	2,212	2,287	2,186	2,036	1,006	690	330
<b>400,000</b>	1,921	2,337	2,416	2,309	2,151	1,062	729	348
<b>450,000</b>	2,016	2,453	2,535	2,424	2,257	1,115	765	366
<b>500,000</b>	2,105	2,561	2,647	2,531	2,357	1,164	798	382
<b>600,000</b>	2,268	2,760	2,853	2,727	2,540	1,254	860	411
<b>700,000</b>	2,416	2,940	3,039	2,905	2,705	1,336	917	438
<b>800,000</b>	2,552	3,105	3,210	3,068	2,858	1,412	968	463
<b>900,000</b>	2,678	3,259	3,369	3,220	2,999	1,481	1,016	468

**Table 11-6**  
**Functions of loading density**

Loading density $w$	Ground shock $f_g$	Debris $f_d$
1.0	0.27	0.60
1.2	0.28	0.62
1.4	0.29	0.64
1.6	0.31	0.65
1.8	0.32	0.67
2.0	0.33	0.68
2.5	0.35	0.71
3.0	0.37	0.73
3.5	0.39	0.75
4.0	0.40	0.77
4.5	0.42	0.79
5.0	0.43	0.80
6.0	0.46	0.83
7.0	0.48	0.85
8.0	0.50	0.87
9.0	0.52	0.89
10.0	0.53	0.91

**Table 11-6**  
**Functions of loading density—Continued**

12.0	0.56	0.94
14.0	0.59	0.96
16.0	0.61	0.99
18.0	0.63	1.01
20.0	0.66	1.03
25.0	0.70	1.07
30.0	0.74	1.11
35.0	0.77	1.14
40.0	0.81	1.17
45.0	0.84	1.19
50.0	0.86	1.21
60.0	0.91	1.25
70.0	0.95	1.29
80.0	0.99	1.32
90.0	1.03	1.35
100.0	1.06	1.37

**Table 11-7**  
**Values for Ratio  $D_{HYD}/V_E^{1/2.8}$**

VE (ft <sup>3</sup> )	$D_{HYD}/V_E^{1/2.8}$					
	Effective Hydraulic Diameter, $D_{HYD}$ (ft)					
	10	15	20	25	30	35
1,000	0.8483	1.2725	1.6967	2.1209	2.5450	2.9692
2,000	0.6623	0.9935	1.3246	1.6558	1.9869	2.3181
3,000	0.5730	0.8595	1.1460	1.4326	1.7191	2.0056
4,000	0.5171	0.7756	1.0341	1.2927	1.5512	1.8097
5,000	0.4775	0.7162	0.9549	1.1937	1.4324	1.6711
6,000	0.4474	0.6710	0.8947	1.1184	1.3421	1.5658
7,000	0.4234	0.6351	0.8468	1.0585	1.2702	1.4819
8,000	0.4037	0.6055	0.8074	1.0092	1.2110	1.4129
9,000	0.3871	0.5806	0.7741	0.9676	1.1612	1.3547
10,000	0.3728	0.5591	0.7455	0.9319	1.1183	1.3047
20,000	0.2910	0.4365	0.5820	0.7275	0.8731	1.0186
30,000	0.2518	0.3777	0.5036	0.6295	0.7554	0.8812
40,000	0.2272	0.3408	0.4544	0.5680	0.6816	0.7652
50,000	0.2098	0.3147	0.4196	0.5245	0.6294	0.7343
60,000	0.1966	0.2949	0.3931	0.4914	0.5897	0.6880
70,000	0.1860	0.2791	0.3721	0.4651	0.5581	0.6511
80,000	0.1774	0.2661	0.3548	0.4434	0.5321	0.6208
90,000	0.1701	0.2551	0.3401	0.4252	0.5102	0.5952
100,000	0.1638	0.2457	0.3276	0.4095	0.4914	0.5733
200,000	0.1279	0.1918	0.2557	0.3197	0.3836	0.4476

**Table 11-7**  
**Values for Ratio  $D_{HYD}/V_E^{1/2.8}$ —Continued**

300,000	0.1106	0.1660	0.2213	0.2766	0.3319	0.3872
400,000	0.0998	0.1497	0.1997	0.2496	0.2995	0.3494
500,000	0.0922	0.1383	0.1844	0.2305	0.2766	0.3226
600,000	0.0864	0.1296	0.1727	0.2159	0.2591	0.3023
700,000	0.0817	0.1226	0.1635	0.2044	0.2452	0.2861
800,000	0.0779	0.1169	0.1559	0.1948	0.2338	0.2728
900,000	0.0747	0.1121	0.1495	0.1868	0.2242	0.2615
1,000,000	0.0720	0.1080	0.1439	0.1799	0.2159	0.2519
2,000,000	0.0562	0.0843	0.1124	0.1405	0.1686	0.1967
3,000,000	0.0486	0.0729	0.0972	0.1215	0.1458	0.1701
4,000,000	0.0439	0.0658	0.0877	0.1097	0.1316	0.1535
5,000,000	0.0405	0.0608	0.0810	0.1013	0.1215	0.1418

**Table 11-8**  
**Scaled inhabited building distance for airblast without mitigating**

NEW (lbs)	$R(\theta)/(D_{HYD}/V_E^{1/2.8})$					
	Horizontal Angle from Centerline Axis					
	0°	30°	60°	90°	120°	180°
1,000	1,545	1,290	895	621	452	273
2,000	1,979	1,653	1,146	718	522	349
3,000	2,287	1,910	1,325	919	669	404
4,000	2,535	2,117	1,468	1,019	741	448
5,000	2,745	2,292	1,590	1,103	803	485
7,000	3,096	2,585	1,793	1,244	905	547
10,000	3,516	2,936	2,037	1,413	1,028	621
20,000	4,504	3,761	2,609	1,810	1,317	759
30,000	5,206	4,347	3,015	2,092	1,522	919
40,000	5,769	4,818	3,341	2,319	1,687	1,019
50,000	6,247	5,217	3,619	2,511	1,827	1,103
70,000	7,045	5,883	4,081	2,831	2,060	1,244
100,000	8,002	6,683	4,635	3,216	2,340	1,413
200,000	11,977	10,002	6,937	4,813	3,502	2,115
250,000	13,633	11,384	7,896	5,479	3,987	2,407
500,000	17,462	14,582	10,114	7,018	5,106	3,083
700,000	19,691	16,444	11,406	7,914	5,759	3,477
1,000,000	22,367	18,678	12,955	8,989	6,541	3,949
2,000,000	28,649	23,925	16,594	11,514	8,378	5,059
3,000,000	33,113	27,652	19,180	13,308	9,684	5,847
5,000,000	39,740	33,187	23,018	15,972	11,622	7,017
7,000,000	44,815	37,424	25,957	18,011	13,106	7,913



**Table 11–8**  
**Scaled inhabited building distance for airblast without mitigating—Continued**

10,000,000	50,903	42,509	29,484	20,458	14,866	8,988
------------	--------	--------	--------	--------	--------	-------

Notes:

<sup>1</sup> IBD for airblast without airblast mitigating devices:

<sup>2</sup>  $R(\theta)/(D_{HYD}/V_E^{1/1.4})=149.3(W^{0.5}/P_{SO}(1+(1/56)^2))^{1/1.4}$  (English Units)

<sup>3</sup> Where:  $P_{SO}=1.2$ psi  $W < 100,000$  lbs

<sup>4</sup>  $P_{SO}=44.57W-0.314$ psi  $100,000 < W < 250,000$  lbs

<sup>5</sup>  $P_{SO} = 0.9$ psi  $W > 250,000$  lbs

<sup>6</sup> Reduce IBD by 50 percent when portal barricade configured in accordance with COE Definitive Drawing 421–80–04 is used.

<sup>7</sup> Reduce IBD as follows when a closure plug designed in accordance with COE Definitive Drawing 421–80–04 is used:

<sup>8</sup> Reduction (percent)=0 percent  $W < 0.0625$  lb/ft<sup>3</sup>

<sup>9</sup> Reduction (percent)=50 log 10(16.02 w)  $0.0625 < W < 0.625$  lb/ft<sup>3</sup>

<sup>10</sup> Reduction (percent)=50 percent  $W > 0.625$  lb/ft<sup>3</sup>

**Table 11–9**  
**Distance versus overpressure along the centerline**

$R=D((P_{SO}/P_W) (1 +\theta/56)^2 )^{(1/135)}$	
<b>Where:</b>	<i>R is the distance from the opening in feet</i>
	D is the effective hydraulic diameter, in feet, that controls flow issuing from the opening. An estimate of D may be obtained from the effective cross section, A, and perimeter, P, of the tunnel or opening (whichever controls the flow) through $D=4A/P$
	$P_W$ is the effective overpressure at the opening (psi) (table 11–11)
	$P_{SO}$ is the overpressure at distance R (psi)
	$\theta$ is the horizontal angle from the centerline (degrees)

$P_W = 895 (W/V_T)^{(1.35/3)}$	
<b>Where:</b>	$W$ is the maximum credible event in pounds
	$V_T$ is the total volume available for gas expansion in cubic feet.

Figure 11–4. Effective overpressure at the opening

$P_{SO} = 1.2$ psi	for	$W < 100,000$ lbs
$P_{SO} = 44.57W^{-0.314}$ psi	for	$100,000 \text{ lbs} \leq W < 250,000$ lbs
$P_{SO} = 0.9$ psi	for	$W > 250,000$ lbs
<b>For these overpressures, the on-axis IBD distances are determined by the following formulas:</b>		
$R = 134[D/V_T^{1/3}] W^{1/3}$	for	$W < 100,000$ lbs
$R = 9.23 [D/VT^{1/3}]W.566$	for	$100,000 \leq W < 250,000$ lbs
$R = 166[D/V_T^{1/3}]W^{1/3}$	for	$W > 250,000$ lbs

Figure 11–5. Allowable overpressure at inhabited building distance

**Table 11-10**  
**Inhabited building distance distances to protect against airblast**

W	R/[D/V <sub>T</sub> <sup>1/3</sup> ] (ft) at selected off-axis angles (deg)					
	0 deg	30 deg	60 deg	90 deg	120 deg	180 deg
1,000	1,340	1,110	760	520	370	220
1,200	1,420	1,180	810	550	400	240
1,400	1,500	1,240	850	580	420	250
1,600	1,570	1,300	890	610	440	260
1,800	1,630	1,350	930	630	460	270
2,000	1,690	1,400	960	660	470	280
2,500	1,820	1,510	1,030	710	510	300
3,000	1,930	1,600	1,100	750	540	320
3,500	2,030	1,690	1,160	790	570	340
4,000	2,130	1,760	1,210	830	600	350
4,500	2,210	1,840	1,260	860	620	370
5,000	2,290	1,900	1,300	890	640	380
6,000	2,430	2,020	1,380	950	680	400
7,000	2,560	2,130	1,460	1,000	720	430
8,000	2,680	2,220	1,520	1,040	750	440
9,000	2,790	2,310	1,580	1,080	780	460
10,000	2,890	2,400	1,640	1,120	810	480
12,000	3,070	2,550	1,740	1,190	860	510
14,000	3,230	2,680	1,830	1,260	900	540
16,000	3,380	2,800	1,920	1,310	940	560
18,000	3,510	2,910	1,990	1,370	980	580
20,000	3,640	3,020	2,070	1,410	1,020	600
25,000	3,920	3,250	2,230	1,520	1,100	650
30,000	4,160	3,450	2,360	1,620	1,160	690
35,000	4,380	3,640	2,490	1,700	1,230	730
40,000	4,580	3,800	2,600	1,780	1,280	760
45,000	4,770	3,950	2,710	1,850	1,330	790
50,000	4,940	4,100	2,800	1,920	1,380	820
60,000	5,250	4,350	2,980	2,040	1,470	870
70,000	5,520	4,580	3,140	2,150	1,550	920
80,000	5,770	4,790	3,280	2,250	1,620	960
90,000	6,010	4,980	3,410	2,340	1,680	1,000
100,000	6,220	5,160	3,530	2,420	1,740	1,030
120,000	6,910	5,730	3,920	2,690	1,930	1,150
140,000	7,540	6,250	4,280	2,930	2,110	1,250
160,000	8,130	6,740	4,620	3,160	2,270	1,350
180,000	8,690	7,210	4,930	3,380	2,430	1,440
200,000	9,220	7,650	5,240	3,590	2,580	1,530
250,000	10,460	8,680	5,940	4,070	2,930	1,730
300,000	11,110	9,220	6,310	4,320	3,110	1,840

**Table 11–10  
Inhabited building distance distances to protect against airblast—Continued**

W	R/[D/V <sub>T</sub> <sup>1/3</sup> ] (ft) at selected off-axis angles (deg)					
350,000	11,700	9,710	6,640	4,550	3,270	1,940
400,000	12,230	10,150	6,950	4,760	3,420	2,030
450,000	12,720	10,550	7,220	4,950	3,560	2,110
500,000	13,180	10,930	7,480	5,120	3,690	2,190
600,000	14,000	11,620	7,950	5,450	3,920	2,320
700,000	14,740	12,230	8,370	5,730	4,120	2,450
800,000	15,410	12,790	8,750	5,990	4,310	2,560
900,000	16,030	13,300	9,100	6,230	4,480	2,660

## Chapter 12 Energetic Liquids

### 12–1. Energetic liquids

*a. Scope and application.* This section applies to the storage of energetic liquids (listed in table 12–2) in all types of containers, including rocket and missile tankage. Laboratory Quantities shall be stored and handled as prescribed by the ACOM, ASCC, or DRU. These QD requirements do not consider the toxicity or potential downwind hazard. Therefore, QD may not be the only factor that needs to be considered when selecting a location for storage and operations of energetic liquids.

*Note.* The required QD is only based on the energetic liquids' energetic reaction (blast overpressure and container fragmentation).

*Note. Exclusion.* This section does not govern the storage or handling of energetic liquids for uses other than in space launch vehicles, rockets, missiles, associated static test apparatus, and ammunition items.

*b. Concept.* These QD standards were developed on the premise that the controlling ACOM, ASCC, or DRU will ensure that the materials of construction are compatible with the energetic liquids, facilities are of appropriate design, fire protection and drainage control techniques are employed, and other specialized controls (such as nitrogen padding, blanketing, and tank cooling) are used when required.

(1) When additional risks associated with ammunition or explosives are involved, the safety distances prescribed in other sections of this chapter shall be applied, as appropriate.

(2) These standards are based upon the estimated credible damage resulting from an incident, without considering probabilities or frequency of occurrence.

### 12–2. Determination of energetic liquids quantity

The total quantity of energetic liquids in a tank, drum, cylinder, or other container shall be the net weight of the energetic liquids contained therein.

*a.* Quantity of energetic liquids in the associated piping must be included to the points that positive means are provided for interrupting the flow through the pipe, or interrupting a reaction in the pipe in the event of an incident.

*b.* When the quantities of energetic liquids are given in gallons, the conversion factors given in table 12–3 may be used to determine the quantity in pounds.

### 12–3. Measurement of separation distances

*a.* Separation distances shall be measured from the closest hazard source (containers, buildings, segment, or positive cutoff point in piping, whichever is controlling).

*b.* When buildings containing a small number of cylinders or drums are present or when quantities of energetic liquids are subdivided effectively, distances may be measured from the nearest container or controlling subdivision.

### 12–4. Hazard classification of energetic liquids

Replacement of the old Hazard Group (I - IV)/Compatibility Group (A - F) classification scheme (referenced in previous editions of DODM 6055.09–M and this DA Pam) for liquid propellants with United Nations (UN) hazard classification nomenclature as defined in Recommendations on the Transport of Dangerous Goods (Reference (d)) has been approved.

*a.* The main hazard classification designator for energetic liquids is either—

- (1) Class 1 (explosives).
- (2) Class 2 (compressed or liquefied gases).

- (3) Class 3 (flammable liquids).
- (4) Class 4 (flammable solids, self-reactive materials).
- (5) Class 5 (oxidizers).
- (6) Class 6 (toxic/infectious substances).
- (7) Class 8 (corrosive).
- (8) Class 9 (miscellaneous).

b. The design and logistics of modern weapons sometimes require that consideration be given to permitting storage or operations involving energetic liquids in a storage structure containing solid explosives. For example, it may be necessary to store hydrocarbon-fueled cruise missiles having high explosive warheads with fueled configurations not containing explosive warheads. Another example is the storage of liquid gun propellant with explosive ammunition components. Since two energetic liquids might each be compatible with certain explosive ammunition stores, but incompatible with each other, a 2-part compatibility group designation is assigned to an energetic liquid.

(1) The first element is the standard storage and transportation CG designation. The alpha designations are the same as the CG designations for UN Hazard Class 1, with the same definitions. However, for storage and handling on DOD facilities, a CG may also be assigned to an energetic liquid in a hazard class other than class 1. The absence of a CG indicates incompatibility with solid explosives.

(2) The second element is a new Energetic Liquid Compatibility Group (ELCG) designation. The ELCG applies to mixed storage of energetic liquids or ammunition components containing energetic liquids. The ELCG is specified in parentheses as the last element of the hazard classification. The ELCG designations and definitions are located in table 12-1, below.

**Table 12-1**  
**Energetic liquid compatibility group**

Designation	Definition	Examples
<b>LA</b>	Energetic liquids that are strong oxidizers, mainly of acidic character. These materials may cause or contribute to the combustion of other material, possibly resulting in serious flare fires or explosions.	Includes, but is not limited to, nitrogen tetroxide and mixed oxides of nitrogen (MON), inhibited red fuming nitric acid (IRFNA), liquid oxygen (LO <sub>2</sub> ), hydrogen peroxide (H <sub>2</sub> O <sub>2</sub> ), and gels, slurries, or emulsions of the above.
<b>LB</b>	Energetic liquids that are readily combustible when exposed to, or ignited in the presence of an oxidizing agent, but that are not strong reducing agents. Some may be hypergolic with group LA materials.	Includes, but is not limited to, hydrocarbons such as kerosene's and strained ring ramjet fuels; liquid hydrogen (LH <sub>2</sub> ); and gels, slurries, or emulsions of the above.
<b>LC</b>	Energetic liquids that are readily combustible when exposed to, or ignited in the presence of an oxidizing agent, and are also strong reducing agents. These will likely be hypergolic with group LA substances.	Includes, but is not limited to, hydrazine's and other amines; and gels, slurries, or emulsions of the above.
<b>LD</b>	Energetic liquids that act mainly as combustible fuels, similar to groups LB and LC, when exposed to, or ignited in the presence of oxidizing agents but that may act as oxidizers in some combinations. They may be a monopropellant with the right catalyst, or may be pyrophoric and ignite upon release to the atmosphere.	Examples are ethylene and propylene oxides, and boranes.
<b>LE</b>	Energetic liquids having characteristics that do not permit storage with any other energetic liquid. They may react adversely with either fuels (reducing agents) or oxidizers.	Examples are nitromethane, nitrate ester based formulations such as Otto Fuel II, liquid monopropellants containing hydroxyl ammonium nitrate (HAN), halogen fluorides (ClF <sub>3</sub> and ClF <sub>5</sub> ) and fluorine, and gels, slurries, or emulsions of the above.

### 12-5. Specific hazardous locations

Aside from the fact that the energetic liquids differ from each other, as explained for the above groups, the predominant hazard of the individual energetic liquids can vary depending upon the location of the energetic liquid storage and the operations involved. In order of decreasing hazard, these conditions are—

a. *Launch pads.* These involve research, development, testing, space exploration, and operational launchings, as well as defense- or combat-type operations that may well be one-time events. Operations at these facilities are very hazardous because of the proximity of fuel and oxidizer to each other, the frequency of launchings, lack of restraint of the vehicle after liftoff, and the possibility of fallback with resultant dynamic mixing on impact. Launch vehicle tankage is involved and explosive equivalents must be used (see table 12-4) with the combined energetic liquids weight subject to mixing except as provided in paragraph 12-5c, below.

*b. Static test stands.* Although these can involve experimental operations, the units remain static and are subject to better control than launch vehicles. Except when run tankage for fuel and oxidizer are mounted one above the other, it may be possible to separate the tankage to reduce the hazard over that for the rocket or missile on the launch pad.

*c. Test stand criteria.* Explosive equivalents shall be used (see table 12-4) with the combined energetic liquids weight subject to mixing as determined by hazard analysis. The amount of energetic liquids held in run tanks can be excluded from consideration if the test stand meets the following criteria:

(1) All tanks are American Society of Mechanical Engineers (ASME) certified and designed and maintained in accordance with section VIII division 1 or division 2 of the ASME code.

(2) For cryogenic propellants, all tanks are constructed with double wall jacketing.

(3) The configuration of the test stand is such that the thrust measuring structure load cell (heavily built structure) is between the engine and the run tanks so as to prevent fragments from puncturing the tanks in case of engine malfunction.

(4) The fuel line contains two remotely operated valves to shut off energetic liquids flow in the event of a malfunction.

*d. Ready storage.* This storage is relatively close to the launch and static test stands; normally it is not involved directly in feeding the engine as in the case with run tankage, which is an integral part of all launch and test stand operations. The explosive equivalents shall be used (see table 12-4) with the combined energetic liquids weight subject to mixing if the facility design does not guarantee against fuel and oxidizer mixing and against detonation propagation to, or initiation at, the ready storage facility when a mishap occurs at the test stand, on the ground at the launch pad, or at the ready storage areas. Otherwise, fire and fragment hazards shall govern (see tables 12-2, 12-3, 12-6, 12-7, and 12-8).

*e. Cold-flow test operations.* Fire and fragment hazards govern tables 12-2, 12-5, 12-6, 12-7, and 12-8, if the design is such that the system is closed except for approved venting, is completely airtight, fuel and oxidizer never are employed concurrently, and each has a completely separate isolated system and fitting types to preclude intermixing, and the energetic liquids are of required purity. Otherwise, explosive equivalents (see table 12-4) shall be used with the combined energetic liquids weight.

*f. Bulk storage.* This is the most remote storage with respect to launch and test operations. It consists of the area, tanks, and other containers therein, used to hold energetic liquids for supplying ready storage and, indirectly, run tankage where no ready storage is available. Fire and fragment hazards govern (see tables 12-2, 12-5, 12-6, 12-7, and 12-8) except in special cases as indicated in tables 12-2 and 12-4.

*g. Rest storage.* This is temporary-type storage and most closely resembles bulk storage. It is a temporary parking location for barges, trailers, tank cars, and portable hold tanks used for topping operations when these units actually are not engaged in the operation; and for such vehicles when they are unable to empty their cargo promptly into the intended storage container. Fire and fragment hazards govern (see tables 12-2, 12-5, 12-6, 12-7, and 12-8) except in special cases as indicated in tables 12-2 and 12-4. The transporter becomes a part of that storage to which it is connected during energetic liquids transfer.

*h. Run tankage (operating tankage).* This consists of the tank and other containers and associated piping used to hold the energetic liquids for direct feeding into the engine or device during operation. The contents of properly separated "run tanks" (operating tankage) and piping are normally considered on the basis of the pertinent hazards for the materials involved, except for quantities of incompatible materials that are or can be in a position to become mixed. HE equivalents shall be used (see table 12-4) for quantities of such materials subject to mixing unless provisions of paragraphs 12-5a through paragraph 12-5d are satisfied.

*i. Pipelines.* A 25-foot clear zone to inhabited buildings shall be maintained, as a minimum, on each side of pipelines used for energetic liquids (excluding flammable or combustible liquids that exhibit normal fire hazards such as RP-1, JP-10, and Otto Fuel II). (see tables 12-2, 12-6, 12-7, and 12-8).apply, as appropriate.

*j. Quantity-distance standards.* Since many energetic liquids are not classified as UN Class 1 explosives, conventional QD storage criteria do not generally apply to these materials. At the same time, the (non-Class 1) UN transportation hazard classifications for many energetic liquids appear to be inappropriate and/or inadequate for application to storage safety (based on available accident and test data). For example, hydrazine has a UN hazard classification of 8 (corrosive), while it also is subject to dangerous fire and explosive behavior. Thus, the implementation of QD criteria for energetic liquids is based on an independent determination of the predominant hazard presented by the material in the storage environment. The following standards are applicable to energetic liquids used for propulsion or operation of missiles, rockets, and other related devices.

*k. Energetic liquid requirements.* Tables 12-2, 12-5, 12-6, 12-7, and 12-8 provide minimum distance requirements for storage of bulk quantities, and in some cases, pressure vessels and other commercial packaging of energetic liquids.

(1) In general, storage of different energetic liquids shall be separated by the minimum distance required by the material requiring the greatest distance.

(2) In addition, positive measures shall be taken to control the flow of energetic liquids in the event of a leak or spill, in order to prevent possible fire propagation or accumulation of flammable liquids near other storage, and/or to

prevent mixing of incompatible energetic liquids (except for specific hazardous locations as identified in paragraphs 12-5b, 12-5c, 12-5d and 12-5h (above).

(3) Explosives equivalence applies for some materials as indicated in tables 12-2 and 12-4. Fragment hazards govern for some materials in certain packaging configurations.

(4) For the more conventional fuels and oxidizers, and also where minimum blast and/or fragment criteria are not required due to low confinement packaging, QD standards are adopted from OSHA and/or National Fire Protection Association (NFPA) guidelines to account for normal fire protection principles.

*l. Explosives equivalency.* For specific hazardous locations as defined in paragraph 12-5 above, explosives equivalency may apply. If so, consult tables 12-2 and 12-4 with the combined energetic liquids weight subject to mixing and use distances found in tables 8-10 or 8-12. Enter weight of explosives equivalent in tables 8-10 or 8-11 QD standards for other conditions and explosive equivalents for any combination not contained in tables 12-2 or 12-4 shall be determined by the controlling ACOM, ASCC, or DRU.

## 12-6. Contaminated energetic liquids

*a.* Caution shall be exercised in the storage and handling of contaminated energetic liquids. Such contamination may increase the degree of hazard associated with the energetic liquids.

*b.* Energetic liquids known to be contaminated or in a suspect condition shall be isolated and provided separate storage from all other energetic liquids pending laboratory analysis for verification of contamination and disposition requirements, if any.

**Table 12-2**  
**Hazard classification and minimum quantity distance for energetic liquids**

Energetic liquid	OSHA/NFPA Fuel <sup>1</sup> or Oxidizer <sup>2</sup> Class	DOD storage hazard class	Minimum QD <sup>3</sup>
Hydrogen Peroxide, > 60 percent	3 or 4 <sup>4</sup>	5.1 (LA)	800 <sup>5</sup> ft or table 12-6
IRFNA	3	8 (LA)	Table 12-4
Nitrogen Tetroxide/MON	2	2.3 (LA)	Table 12-4
Liquid Oxygen	N/A	2.2 (LA)	Table 12-5
RP-1	II	3 (LB)	Table 12-5
JP-10	II	3J (LB)	Table 12-5
Liquid Hydrogen		2.1 (LB)	Table 12-8
Hydrazine, > 64 percent	II	8 (LC)	800 <sup>5</sup> or 300 <sup>6</sup> ft or Note 7
Aerozine 50 (50 percent N <sub>2</sub> H <sub>4</sub> /50 percent UDMH)	I B	6.1 (LC)	800 <sup>5</sup> or 300 <sup>6</sup> ft or Note 7
Methylhydrazine	I B	6.1 (LC)	800 <sup>5</sup> or 300 <sup>6</sup> ft or Note 7
UDMH	I B	6.1 (LC)	Table 12-5
Ethylene Oxide	I A	2.3 (LD)	H/D 1.1 QD <sup>8</sup> with TNT Equiv=100 percent, or 800 <sup>5</sup> or 300 <sup>6</sup> ft
Propylene Oxide	I A	3 (LD)	H/D 1.1 QD <sup>8</sup> with TNT Equiv=100 percent, or 800 <sup>5</sup> or 300 <sup>6</sup> ft
Nitromethane	I C	3 (LE)	Use H/D 1.1 QD with TNT Equiv=100 percent <sup>9</sup> or table 12-5
Hydroxylammonium Nitrate (HAN)	2	8 (LE)	800 <sup>5</sup> ft or table 12-6
XM-46 (HAN Monopropellant)	N/A	1.3C (LE)	800 <sup>5</sup> ft or use H/D 1.3 QD
Otto Fuel II	III B	9 (LE)	Use H/D 1.1 QD <sup>10</sup> with TNT Equiv=100 percent, or 150 <sup>11</sup> ft, or table 12-5
Halogen Fluorides (ClF <sub>3</sub> /ClF <sub>5</sub> )	4	2.3 (LE)	Table 12-6
Liquid Fluorine	4	2.3 (LE)	Table 12-6
Nitrogen Trifluoride	4	2.2 (LE)	Table 12-6

**Table 12-2  
Hazard classification and minimum quantity distance for energetic liquids—Continued**

Nitrate esters (NG, TMETN, DEGDN, TEGDN, BTTN)	N/A	1.1 D (LE)	Use H/D 1.1 QD with TNT Equiv=100 percent
--	-----	------------	---

Notes:

<sup>1</sup> The Flammable or combustible liquid classification index based on flash point and boiling point versus criteria as specified in 29 CFR 1910.106 (OSHA) and NFPA 30 Flammable and Combustible Liquids Code). Primary descriptor is a Roman numeral, possibly with an additional letter.

<sup>2</sup> NFPA oxidizer classification index as described in NFPA 430 Code for the Storage of Liquid and Solid Oxidizers. Descriptor is an ordinary number.

<sup>3</sup> Positive measures for spill containment/control shall be taken for isolated storage of energetic liquids in accordance with applicable OSHA and NFPA guidance (referenced in tables 12-5 through 12-7). For flammable energetic liquids and liquid oxidizers where only minimum blast or fragment distances are specified, applicable OSHA and/or NFPA guidance referenced in table 12-5 and 12-7, respectively, should also be used.

<sup>4</sup> Hydrogen peroxide solutions of concentration greater than 91 percent are NFPA Class 4 oxidizers.

<sup>5</sup> Should be used as a default value, unless otherwise hazard classified, when the material is packaged in small (non-bulk) shipping containers, portable ground support equipment, small aerospace flight vehicle propellant tanks, or similar pressure vessels that provide heavy confinement (burst pressure greater than 100 psi).

<sup>6</sup> Should be used as a default value, unless otherwise hazard classified, when the material is packaged in small (non-bulk) shipping containers (DOT 5C or equivalent), portable ground support equipment, small aerospace flight vehicle propellant tanks, or similar pressure vessels providing a lower level of confinement (burst pressure less than or equal to 100 psi) and if adequate protection from fragments is not provided from terrain, effective barricades, nets, or other physical means (lightweight building construction is not adequate). If protection from fragments is provided, use the IBD/PTRD Protected Distance column of table 12-8.

<sup>7</sup> For large ready, bulk, or rest storage tanks (as defined in paragraphs 12-5d, 12-5e, and 12-5f, use table 12-8.

<sup>8</sup> Where there is a reasonable risk of vapor cloud explosion of large quantities (for example, in bulk tank storage).

<sup>9</sup> Technical grade nitromethane in unit quantities of 55 gallons or less in DOT approved containers listed in 49 CFR 173.202 may be stored as flammable liquids (table 12-5) provided packages are stored only one tier high, packages are protected from direct rays of sun, maximum storage life of two years, unless storage life tests indicate product continues to meet purchase specifications. Such tests are to be replaced at one-year intervals thereafter.

<sup>10</sup> For underwater static test stands, when operated at hydrostatic pressure above 50 psig, or for propellant tanks or other vessels having burst pressures of greater than 100 psig without acceptable pressure relief devices (unless otherwise hazard classified). For underwater test stands, the TNT equivalence (MCE) should include the total propellant weight in all pumps and plumbing, as well as the weight of propellant held in tankage (under the test cell hydrostatic pressure) unless acceptable mitigation measures such as fuel line detonation arrestors and/or fuel tank isolation/barricading are used (as determined by hazard analysis).

<sup>11</sup> Should be used as a default value, unless otherwise hazard classified, when the material is packaged in small vehicle propellant tanks, small (non-bulk) shipping containers, portable ground support equipment, or similar pressure vessels that provide relatively heavy confinement (burst pressure between 50 - 100 psig) without acceptable pressure relief devices.

**Table 12-3  
Factors to use when converting gallons of energetic liquids into pounds<sup>1</sup>**

Item	Pounds per gallon	At Temperature °F
Chlorine Pentafluoride	14.8	77
Chlorine trifluoride	15.1	77
Ethyl alcohol	6.6	68
Ethylene oxide	7.4	51
Fluorine (liquid)	12.6	-306
HAN Monopropellants	11.9	77
HAN solution (25 to 95 wt percent)	10.0 to 13.4	68
Hydrazine	8.4	68
Hydrogen peroxide (90 percent)	11.6	77
JP-10	7.8	60
Liquid hydrogen	0.59	-423
Liquid oxygen	9.5	-297
Monomethyl hydrazine	7.3	68
Nitrogen tetroxide	12.1	68
Nitrogen trifluoride	12.8	-200
Nitromethane	9.5	68
Otto Fuel II	10.3	77
Propylene oxide	7.2	32

**Table 12-3**  
**Factors to use when converting gallons of energetic liquids into pounds<sup>1</sup>—Continued**

Red fuming nitric acid (IRFNA)	12.9	77
RP-1	6.8	68
UDMH	6.6	68
UDMH/hydrazine	7.5	77

Notes:

<sup>1</sup> Conversion of quantities of energetic liquids from gallons to pounds: Pounds of energetic liquids=gallons X density of energetic liquids in pounds per gallon.

**Table 12-4**  
**Energetic liquid explosive equivalents<sup>1,2,3,4,5</sup>**

Energetic liquids	TNT equivalence	Range launch
	Static test stands	
LO <sub>2</sub> /LH <sub>2</sub>	See Note 6	See Note 6
LO <sub>2</sub> /LH <sub>2</sub> + LO <sub>2</sub> /RP-1	Sum of (see note 6 for LO <sub>2</sub> /LH <sub>2</sub> ) + (10 percent for LO <sub>2</sub> /RP-1)	Sum of (see Note 6 for LO <sub>2</sub> /LH <sub>2</sub> ) + (20 percent for LO <sub>2</sub> /RP-1)
LO <sub>2</sub> /RP-1	10 percent	20 percent up to 500,000 pounds plus 10 percent over 500,000 pounds
IRFNA/UDMH <sup>7</sup>	10 percent	10 percent
N <sub>2</sub> O <sub>4</sub> /UDMH + N <sub>2</sub> H <sub>4</sub> <sup>7</sup>	5 percent	10 percent
N <sub>2</sub> O <sub>4</sub> liquid oxidizer + PBAN solid fuel (Hybrid propellants)	15 percent <sup>8</sup>	15 percent <sup>8</sup>
Nitromethane (alone or in combination)	100 percent	100 percent
Otto Fuel II	100 percent <sup>9</sup>	
Ethylene Oxide	100 percent <sup>10</sup>	100 percent <sup>10</sup>

Notes:

<sup>1</sup> The percentage factors given in the table are to be used to determine equivalencies of energetic liquids mixtures at static test stands and range launch pads when such energetic liquids are located aboveground and are unconfined except for their tankage. Other configurations shall be considered on an individual basis to determine equivalencies.

<sup>2</sup> The explosives equivalent weight calculated by the use of this table shall be added to any nonnuclear explosive weight aboard before distances can be determined from tables 8-10 and 8-12.

<sup>3</sup> These equivalencies apply also for alcohol's or other hydrocarbons for RP-1, H<sub>2</sub>O<sub>2</sub> for LO<sub>2</sub> (only when LO<sub>2</sub> is in combination with RP-1 or equivalent hydrocarbon fuel), and MMH for N<sub>2</sub>H<sub>4</sub>, UDMH, or combinations of the two.

<sup>4</sup> For quantities of energetic liquids up to but not over the equivalent of 100 pounds of explosives, the distance shall be determined on an individual basis by the ACOM, ASCC, or DRU. All personnel and facilities, whether involved in the operation or not, shall be protected by operating procedures, equipment design, shielding, barricading, or other suitable means.

<sup>5</sup> Distances less than ILD are not specified. Where a number of prepackaged energetic liquid units are stored together, separation distance to other storage facilities shall be determined on an individual basis by the ACOM, ASCC, or DRU, taking into consideration normal hazard classification procedures.

<sup>6</sup> For siting launch vehicles and static test stands, explosive equivalent weight is the larger of the weight equal to  $8W^{2/3}$  where W is the weight of LO<sub>2</sub>/LH<sub>2</sub>, or 14 percent of the LO<sub>2</sub>/LH<sub>2</sub> weight. For these calculations, use the total weight of LO<sub>2</sub>/LH<sub>2</sub> present in the launch vehicle, or the total weight in test stand run tankage and piping for which there is no positive means to prevent mixing incredible mishaps. When it can be reliably demonstrated that the maximum credible event involves a lesser quantity of energetic liquids subject to involvement in a single reaction, the lesser quantity may be used in determining the explosive equivalent yield. When siting is based on a quantity less than the total energetic liquids present, the maximum credible event and associated explosive yield analysis must be documented in an approved site plan (DA Pam 385-65).

<sup>7</sup> These are hypergolic combinations.

<sup>8</sup> Explosive equivalency of the hybrid rocket system N<sub>2</sub>O<sub>4</sub> liquid oxidizer combined with PBAN solid fuel was evaluated in 200-pound tests (reference (ae)). These tests indicate a maximum TNT equivalency of 15 percent for an explosive donor accident scenario, 5 percent for a high velocity impact scenario, and less than 0.01 percent (negligible) for static mixing (tower drop) failures.

<sup>9</sup> See note 10 of table 12-2.

<sup>10</sup> See note 8 of table 12-2



**Table 12–5**  
**Quantity-distance criteria for Occupational Safety and Health Administration/National Fire and Protection Association Class I - III flammable and combustible energetic liquids storage in detached buildings or tanks<sup>1,2</sup>**

Quantity	IBD/PTRD (ft)	ILD/Aboveground IMD (ft)
Unlimited <sup>3</sup>	50 <sup>4,5</sup>	Note <sup>6</sup>

Notes:

<sup>1</sup> Other guidelines for diking, tank or container construction, tank venting, and facility construction apply (except for Class III B combustible liquids, such as, Otto Fuel II). Refer to 29 CFR 1910.106) and NFPA 30 Flammable and Combustible Liquids Code for further guidance on liquid storage and fire protection.

<sup>2</sup> Refer to 29 CFR 1910.106 and NFPA 30 Flammable and Combustible Liquids Code) for definition and explanation of OSHA/NFPA classification of flammable and combustible liquids.

<sup>3</sup> Guidelines on interior storage configuration (for container storage inside buildings) also apply with the following exceptions: (a) If the storage building is located at least 100 ft from any exposed building (under the direct jurisdiction of a fire protection organization) or property line; or (b) If the storage building is located at least 200 ft from any exposed building (not under the direct jurisdiction of a fire protection organization) or property line; or (c) for combustible liquids that will not exhibit sustained burning in bulk form, such as, Otto Fuel II, as determined through ASTM D 92 Standard Test Method for Flash and Fire Points by Cleveland Open Cup or comparable testing. Refer to 29 CFR 1910.106) and NFPA 30 Flammable and Combustible Liquids Code) for further guidance on liquid storage and fire protection.

<sup>4</sup> For container storage inside of a building, IBD/ PTRD may be less than 50 ft (to a minimum of 10 ft) if the storage building is constructed of fire resistive exterior walls having an NFPA Fire Resistance rating of two hours or more according to NFPA 251.

<sup>5</sup> For large tank storage, QD may be 25 feet for tank capacities up to 100,000 gallons, and 37.5 feet for capacities between 100,001 and 500,000 gallons.

<sup>6</sup> For flammable liquids container storage inside of a building, ILD/Aboveground IMD is 50 feet (accept as in Note 4), or for adjacent incompatible oxidizer storage, distances specified for energetic liquid oxidizers (table 12–6) or oxygen (table 12–7). For flammable liquids storage in fixed or large portable tanks, ILD/Aboveground IMD is either (1) for compatible energetic liquids, equal to one sixth of the sum of the diameters of the two adjacent tanks, or distances specified in Note 5 for adjacent container storage inside of a building; or (2) for adjacent incompatible oxidizer storage, distances specified for energetic liquid oxidizers (table 12–6) or oxygen (table 12–7) . Earth-covered magazines may be used to their physical capacity for storing flammable energetic liquids provided they comply with the construction and siting requirements of this Pamphlet for Hazard Division 1.1. The earth-covered magazines must be sited for a minimum of 100 lbs of Hazard Division 1.1 items using tables 8–14 and 8–15.

**Table 12–6**  
**Quantity-distance criteria for energetic liquid oxidizer (excluding liquid oxygen) storage in detached buildings or tanks<sup>1, 2</sup>**

NFPA Oxidizer Class <sup>3</sup>	Quantity (lbs)	IBD/PTRD/ILD/ Aboveground IMD (ft)
2	up to 600,000	50
3	up to 400,000	75
4 <sup>4,5</sup>	< 50	75
	70	76
	100	79
	150	84
	200	89
	300	98
	500	114
	700	128
	1,000	147
	1,500	175
	2,000 <sup>6</sup>	200
	3,000	246
	5,000	328
	7,000	404
	10,000	510
15,000	592	
20,000	651	
30,000	746	
50,000	884	

**Table 12-6**  
**Quantity-distance criteria for energetic liquid oxidizer (excluding liquid oxygen) storage in detached buildings or tanks<sup>1</sup>.**  
<sup>2</sup>—Continued

	70,000	989
	100,000	1,114
	150,000	1,275
	200,000	1,404
	300,000	1,607
	500,000	1,905

Notes:

<sup>1</sup> QD requirements do not apply to storage of NFPA Class 2 and 3 oxidizers in approved fixed tanks.

<sup>2</sup> Other requirements for interior storage configuration, building construction, diking, container materials, facility venting, and so forth, also apply. Refer to NFPA 430 Code for the Storage of Liquid and Solid Oxidizers for further guidance on oxidizer storage and fire protection.

<sup>3</sup> Refer to NFPA 430 Code for the Storage of Liquid and Solid Oxidizers for definition and explanation of NFPA classification of oxidizers.

<sup>4</sup> Multiple tanks containing NFPA Class 4 oxidizers may be located at distances less than those specified in the table; however, if the tanks are not separated from each other by 10 percent of the distance specified for the largest tank, then the total contents of all tanks shall be used to calculate distances to other exposures.

<sup>5</sup> Notes for NFPA Oxidizer Class 4: (a)  $W < 10,000$  lbs, Distance= $149.3 \times W^{(-0.41+0.059 \times \ln(W))}$ ; (b)  $W < 10,000$  lbs, Distance= $24 \times W^{1/3}$ ; (c) Use of equations given in (a) and (b) to determine distances for other quantities (W) is allowed.

<sup>6</sup> NFPA 430 requires sprinkler protection to be provided for storage of greater than 2,000 pounds of NFPA Class 4 oxidizers inside of a building.

**Table 12-7**  
**Quantity-distance criteria for liquid oxygen <sup>1,2</sup>**

	IBD/PTRD (ft)	ILD/Aboveground IMD (ft)
Unlimited <sup>3</sup>	100	100 <sup>4</sup>

Notes:

<sup>1</sup> Distances do not apply where a protective structure having an NFPA fire resistance rating of at least two hours according to NFPA 251 interrupts the line of sight between the oxygen system and the exposure. Refer to 29 CFR 1910.104 and NFPA 50 Standard for Bulk Oxygen Systems at Consumer Sites for further guidance.

<sup>2</sup> Additional guidelines relating to equipment assembly and installation, facility design (diking), and other fire protection issues also apply. Refer to 29 CFR 1910.104 and NFPA 50 Standard for Bulk Oxygen Systems at consumer sites for further guidance.

<sup>3</sup> QD is independent of oxygen quantity.

<sup>4</sup> Minimum ILD/IMD distance between adjacent compatible energetic liquids storage is 50 feet.

Propellant Weight (pounds)	IBD/PTRD		ILD/Aboveground IMD (ft) <sup>6,7</sup>
	Unprotected (ft) <sup>2,3</sup>	Protected (ft) <sup>4,5</sup>	
0 -100	600	80	30
200	600	100	37
300	600	113	42
400	600	122	46
500	600	130	49
600	600	136	51
700	600	141	53
800	600	145	54
900	600	149	56
1,000	600	153	57
2,000	600	176	66
3,000	600	191	72
4,000	600	202	76
5,000	600	211	79
6,000	600	218	82
7,000	600	224	84
8,000	600	230	86
9,000	600	235	88
10,000	603	239	90
15,000	691	258	97
20,000	760	272	102
25,000	819	283	106
30,000	870	292	110
35,000	916	301	113
40,000	958	308	116
45,000	996	315	118
50,000	1,032	321	120
60,000	1,096	332	124
70,000	1,154	341	128
80,000	1,206	349	131
90,000	1,255	357	134
100,000	1,300	364	136
125,000	1,400	379	142
150,000	1,488	391	147
175,000	1,566	403	151

Figure 12-1. Quantity-distance criteria for liquid hydrogen and bulk quantities of hydrazines <sup>1</sup>

Propellant Weight (pounds)	IBD/PTRD		ILD/Aboveground IMD (ft) <sup>6,7</sup>
	Unprotected (ft) <sup>2,3</sup>	Protected (ft) <sup>4,5</sup>	
200,000	1,637	412	155
250,000	1,764	429	161
300,000	1,800	444	166
350,000	1,800	457	171
400,000	1,800	468	175
450,000	1,800	478	179
500,000	1,800	487	183
600,000	1,800	503	189
700,000	1,800	518	194
800,000	1,800	530	199
900,000	1,800	542	203
1,000,000 <sup>8</sup>	1,800	552	207
2,000,000	1,800	626	235
3,000,000	1,800	673	252
4,000,000	1,800	708	266
5,000,000	1,800	737	276
6,000,000	1,800	761	285
7,000,000	1,800	782	293
8,000,000	1,800	800	300
9,000,000	1,800	817	306
10,000,000	1,800	832	312

*Note:*

1. Positive measures shall be taken to prevent mixing of hydrogen or hydrazine's and adjacent oxidizers in the event of a leak or spill.
2. Distances are necessary to provide reasonable protection from fragments of tanks or equipment that are expected to be thrown in event of a vapor phase explosion.
3.  $10,000 < W \leq 265,000$  lbs, Unprotected Distance =  $28xW^{1/3}$ . Also  $W = (\text{Unprotected Distance}/28)^3$ .
4. The term "protected" means that protection from fragments is provided by terrain, effective barricades, nets, or other physical means.
5. Distances are based on the recommended inhabited building distances given in the Bureau of Mines, Department of the Interior Report No. 5707, dated 1961, and extrapolation thereof (2 cal/cm<sup>2</sup> on 1 percent water vapor curve). Curve fit of the data yields Protected Distance =  $-154.1 + 72.89x[\ln(W)] - 6.675x[\ln(W)]^2 + 0.369x[\ln(W)]^3$ .
6. Also  $W = \exp[311.367 - 215.761x[\ln(\text{protected distance})] + 55.1828x[\ln(\text{protected distance})]^2 - 6.1099x[\ln(\text{protected distance})]^3 + 0.25343x[\ln(\text{protected distance})]^4]$ .
7. ILD/Aboveground IMD distances in this column apply for adjacent compatible (ELCG LB or LC) storage; for adjacent incompatible (other ELCG) storage, use IBD distances shown in previous columns. Earth-covered magazines may be used to their physical capacity for storing hydrogen provided they comply with the construction and siting requirements of this Pamphlet for Hazard Division 1.1. The earth-covered magazines must be sited for a minimum of 100 lbs of Hazard Division 1.1 items using tables 8-14 and 8-15.
8. Distances are an average of 37.5 percent of "protected" column.

**Figure 12-1. Quantity-distance criteria for liquid hydrogen and bulk quantities of hydrazines<sup>1</sup>-continued**

- 
9. Extrapolations above 1,000,000 pounds extend well outside data included in the Bureau of Mines, Department of the Interior, Report 5707, dated 1961, from which the original QD tables were derived; however, they are supported by independent calculations and knowledge of like phenomena.

Figure 12–1. Quantity-distance criteria for liquid hydrogen and bulk quantities of hydrazines <sup>1</sup>-continued

---

## Chapter 13 Military Working Dog Explosives Search Training

### 13–1. General

*a. Background.* Realistic and effective training of MWDs to detect explosives requires simulated searches using real explosives samples in areas that are normally inhabited. Training will be conducted so that all persons unrelated to the training of the dogs are not exposed to the risks associated with an accidental explosion of a training sample. MWD explosive use, guidance, physical security, training, transportation, and explosive use will be in accordance with AR 190–12, with the safety training/requirements, procurement, types, characteristics, and quantities of explosives authorized for use in training specified in chapter 5, DA Pam 190–12. Detailed instructions are provided in DA Pam 190–12, chapter 4 for the control, storage, security, and accountability of explosive training aids.

*b. Operations on explosives used for training.* Only qualified personnel will operate on training explosives samples. Such activities as unpacking, handling, cutting, dividing, and repacking will be conducted in facilities that meet the QD and other requirements of this pamphlet.

*c. Storage of explosives used for training.* Explosives must be stored in facilities that meet the QD and other requirements of this pamphlet.

*d. Training safety procedures.* All personnel associated with MWD training will be trained by EOD or safety personnel in the safe storage, transportation, and handling of each type of explosive used as training aids before conducting or participating in this proficiency training. Persons unrelated to the training of the dogs must not be exposed to the risks associated with an accidental explosion of a training sample. Therefore, at the training site—

(1) Commanders will ensure safety training for using explosives training aids is available before seeking authorizations for MWDs and handlers.

(2) The number of samples and the quantity of explosives will be the minimum to conduct the exercise. When deployed, adjacent samples should be separated to preclude propagation from one to another. The distance for non-propagation is  $D=11W^{1/3}$ .

(3) For quantities of explosives of 15 lbs NEW or less, all unrelated personnel must be evacuated from the training area to at least 100 feet from the explosives. For quantities over 15 pounds, the evacuation distance is  $D=40W^{1/3}$ .

(4) Explosives should be packaged by type required, and in the sizes needed.

(5) Blasting caps, squibs, explosive detonators, or any initiating explosives must not be used for any type of explosives detection training.

(6) Explosives training aids will be transported only in Government vehicles which have been certified as safe for explosives transportation by explosives safety personnel. All explosive items carried by means of a tractor or flat-bed trailer in a dromedary freight box must be compatible and in compliance with 49 CFR 177 (ref (c)) or host nation regulations. (DOD 5100.76–M)

(7) Keep training explosive samples under surveillance at all times. Collect all aids and conduct an inventory immediately after each training event.

(8) Samples must not be placed near any heat or spark producing items such as bare electrical wiring, radiators, electric heaters, heating vents, or any other source of potential initiation.

(9) Do not conduct training when lightning is reported within 3 miles of the training area. Contact garrison or installation range controls for weather conditions before training.

*e.* ACOM, ASCC, or DRU commanders, with HQDA (DAMO–ODL–S) concurrence, may authorize additional explosives training aids when the use of other explosives substances is identified and such use merits development of a detection capability.

### 13–2. Safety precautions

Personnel must follow mandated safety requirements when training with explosive devices. Training is not to be

conducted unless detailed operating procedures including safety instructions are developed. See AR 190–12 and DA Pam 190–12.

## **Chapter 14**

### **Maintenance of Ammunition and explosives**

#### **14–1. General information**

*a.* Maintenance is maintaining ammunition and explosives in a serviceable condition or restoring them to that condition. It includes such operations as renovation, modification, preservation, and packaging.

*b.* Maintenance includes all operations from the time of delivery of the ammunition to the maintenance building to the time it is ready for shipment to storage or issue. Maintenance operations involve the following: line layout, establishing barricades as appropriate, setting up equipment, partial or complete disassembly of ammunition items, cleaning parts or subassemblies, repair or replacement of mechanical parts, replacement of explosive components, reassembly, repainting and remarking, and the repacking and remarking for shipment and delivery to an ammunition issuing point.

*c.* Renovation or modification of conventional ammunition, missiles, ammunition or missile components and explosives will be accomplished only with specific authority from Joint Munitions Command (JMC), Aviation and Missile Command (AMCOM), or other authority as appropriate.

*d.* The necessary preservation and packing (P&P) may be performed on unserviceable ammunition and components when a requirement exists.

#### **14–2. Safety requirements**

*a. Renovation.*

(1) Renovation will be performed in an isolated area or building specifically designed for that purpose. These operations will be carried out in conformity with the QD requirements of chapter 8. The number of persons permitted at or near the operation will be kept to a minimum. The area or buildings will be kept free of loose explosives, waste paper, and other combustible material. All work will be performed under the direct supervision of experienced personnel.

(2) Renovation operations can be hazardous. They require a thorough knowledge of the activities involved, the hazards to be guarded against, and the precautionary methods necessary for greatest protection to personnel and property. Before starting any operation involving ammunition or explosives, an adequate SOP will be developed and approved—

(*a*) By the commander of the establishment, or,

(*b*) By a qualified member of their staff who has been delegated authority to review and approve the SOP, or,

(*c*) By personnel as required by contract.

(3) Controlled tests may be necessary to establish SOPs for certain operations. The SOPs will include, as a minimum, such items as safety requirements, personnel and explosives limits, equipment designation, and location and sequence of operations. A dry run will be done using inert components to ensure that the SOP includes all necessary operations, equipment and, procedures. No deviation from this procedure will be permitted unless the commander or his or her designated representative approves.

*b. Allowable limits.* The quantity of ammunition or explosives at an operating location will be the minimum necessary to carry out the operation. This quantity will be subdivided to the maximum extent possible into smaller amounts, adequately separated to prevent propagation. Personnel exposure will be the minimum consistent with safe, efficient, and continuous operation.

*c. Internal movement of explosives.*

(1) Items or groups of items of ammunition and explosives that are transported from bay to bay within an operating building, will be separated to preclude creating a path for the propagation of an explosion or fire between bays. For this purpose, the minimum spacing between items or groups of items in transport will be ILD.

(2) The use of less than ILD (with or without barricades or other substitutes for distance) will require testing or engineering analysis to prove that shorter distances are safe for the intended operation.

(*a*) An acceptable test protocol giving a 95 percent probability with a 95 percent confidence level that a worst-case credible reaction of one item will not propagate to the other is the conduct of fifty consecutive confirmatory tests with no propagation observed.

(*b*) Other test methodologies can be used provided the test plan adequately demonstrates that the successful completion of the test will assure the same probability and level of confidence as stated before.

(*c*) Separations approved under this methodology are only applicable to the configuration and orientation of the item as tested. Test plans and subsequent test results must be submitted to the US Army Joint Munitions Command (JMC)/

AMSJM-SF, 1 Rock Island Arsenal, Rock Island, IL 61299-6000 for approval and eventual incorporation into appendix F of this pamphlet.

(3) Another methodology to justify the use of reduced separations is by analogy with similar previously tested items. A good analogy could be against items from the same family/caliber, fill type and amount, shielding/body wall material and thickness. Analogy proposals must be submitted for approval to the JMC as indicated in paragraph 14-2c(2), above.

(4) The use of shields or barriers is another method to interrupt the propagation path between items on a conveyor, in a corridor, or other potential propagation path. These could be incorporated into the testing explained above to aid in reducing the spacing even more. Appendix F shows the approved safe separation distances of conveyor spacing for specified items based on configuration of the item, position on the conveyor, distance between items and, if needed, the shield or barricade.

*d. Concurrent operations.*

(1) Unless a building is specifically designed and approved for concurrent operation, permissible concurrent operations will be accomplished in separate buildings located at the appropriate ILD from other operating buildings in the area.

(2) When necessary to conduct concurrent operations in the same building, they must be arranged in a manner to segregate the items so that dissimilar risks are separated by a reinforced concrete dividing wall. Unrelated personnel involved in concurrent operations in a single building must be afforded protection equivalent to ILD (K18).

(3) The quantities of explosives and number of personnel exposed at each concurrent operation will be held to the minimum consistent with safe and efficient operating procedures.

*e. Operations within a magazine area.*

(1) Ammunition and explosives will not be renovated, modified, or demilitarized within a magazine. These operations will not be carried on within the magazine area unless the site, empty magazine, buildings, or rail cars in which the work is done are assigned exclusively to such work. Temporary operations outside of the magazine may be carried out as permitted in (2), below. Permanent structures involving labor intensive operations must be properly sited with an approved site plan.

(2) The performance of P&P operations in the magazine area may be approved by the garrison or installation commander as field operations and separated from the potential explosion site by ILD based on the larger quantity of NEW at either the potential explosion site or exposed site. Such operations will be limited to removing rust and painting of bombs and separate loading projectiles, opening and repacking boxes and metal containers of ammunition (including chemical ammunition), repacking of ammunition into serviceable boxes and fiber containers, spot painting projectiles, maintenance of fuze cavities and base covers of separate loading projectiles, and other relatively safe operations of the same general type.

*f. Division of explosive quantities.* The division of large quantities of explosives material into a number of smaller quantities, using dividing walls, is intended to prevent the simultaneous explosion of the total quantity involved. If the explosives on both sides of a dividing wall are prevented from exploding simultaneously, the wall achieves its purpose. If this requirement is met, then, for the purpose of QD computations, the quantities separated by dividing walls need not be added together. Design of intervening barriers in accordance with the principles contained in TM 5-1300 will satisfy this requirement. Information on barricaded open storage modules meeting this criterion are given in paragraph 8-4d.

### **14-3. Operational shields**

*a. Shields required.* Operational shields are required when the operation to be performed provides an unacceptable risk of exposure as defined by paragraph 8-28.

(1) Operational shields prevent operator exposure to blast overpressure in excess of 2.3 psi, fragments to energies of less than 59 ft-lb, and thermal fluxes to 0.3 calories per square centimeter per second. For operations involving intentional initiation or detonation, operational shields shall be capable of limiting overpressure levels (decibels) in personnel-occupied areas to satisfy the requirements of MIL-STD-1474C. (MIL-STD-1474C overpressures are expressed as decibels. The conversion factor is:  $\text{dB}=20(\log (144/4.2 \times 10^7))$ ).

(2) Shields complying with MIL-STD 398 are acceptable protection. Shields which have not been tested in accordance with the requirements of MIL-STD-398 shall be evaluated by competent personnel before being used in ammunition operations.

(3) Determination of the maximum credible event for the materials and operational scenario involved is an essential part of the evaluation of the operator protection requirements.

*b. Unacceptable risk.* In addition to those operations where a risk assessment in accordance with DA Pam 385-30 shows a unacceptable level of risk, operational shields will be provided to separate the operator from the item being processed for the following operations:

(1) Disassembly of loaded boosters, fuzes, primers, and blank ammunition.

(2) Removal of base plugs from loaded projectiles where the design of the projectile is such that explosive contamination of the base plug is not positively precluded.

(3) Removal of fuzes from pentolite loaded projectiles.

(4) Disassembly of loaded bombs and warheads, except for removal of shipping bands, nose and tail closing plugs, fin locknuts, and washout of high explosives bursting charge, unless covered by an approved letter of instruction (LOI)/ Depot Maintenance Work Requirement.

(5) Removal of fuzes from hand grenades loaded with high explosives except as noted in c (6) below.

(6) Pull-apart of fixed ammunition, 20 mm and larger. In the pull-apart of rounds containing self-destroying tracer, the shield design will use initiation of the propellant and the projectile as the maximum credible event. Pull-apart of ammunition with inert projectiles will use initiation of the propellant as the maximum credible event. Pull-apart of ammunition with explosives loaded projectile, but without self-destroying tracer, will use initiation of the propellant as the maximum credible event.

(7) Disassembly of foreign ammunition or other ammunition of uncertain design and condition.

(8) Electrical testing of igniter circuitry of rockets, missiles, or any other electrically initiated explosives item. Electrical testing of igniter circuitry in missile and rocket motors and other propulsion systems shall use initiation of the propellant as the maximum credible event. Electrical testing of initiating components of warheads, projectiles, and similar items shall use initiation of the warhead or projectile and propellant as the maximum credible event unless hazards analysis shows negligible probability that test-energized circuitry could cause explosives functioning.

*c. Shields not required.* The operations paragraphs (1) through (6), below and similar operations do not require operational shields to protect operators if the assembly has been normal, and if regular equipment, tools, and methods used in the assembly are sufficient to accomplish the disassembly without the application of undue force. Undue force is considered to be any force greater than the maximum allowable disassembly torque specified on the current drawings for the item under consideration. Tools used for disassembly will not have greater lever advantage than those required for the assembly. In these cases, care will be taken to ascertain that the assembly has been normal and the surfaces to be separated are not corroded and have not been sealed with metallic caulking, laminac, or epoxy resin whose strength exceeds the adhesive properties of Pettman Cement or NRC compound.

(1) Removal of loaded fuzes and fuze well cups from loaded projectiles.

(2) Removal of primers from mortar ammunition.

(3) Removal of ignition cartridges from mortar ammunition.

(4) Removal of boosters or bursters from loaded projectiles.

(5) Removal of setscrew from loaded projectiles. When drilling equipment is used to remove stake-punch marks and back out setscrews, positive stops on the drill must be provided to prevent the contact of the drill with the component parts of the fuze or booster which contain explosives or with the explosives in the projectile. Drills will be changed and positive stop set only by competent mechanics. Only fully trained personnel will be used for such operations. Before the operation is begun, the projectile must be examined for the presence of explosive exudate or other abnormal conditions.

(6) Removal of detonating fuzes from hand grenades designed with metal fuze well liners provided:

(a) The operation is performed immediately in front of a suitable protective tank having effective baffles for delay type fuzes into which the grenade can be deposited should it ignite prematurely. Baffle type tanks will not be used for grenades having impact fuzes.

(b) Shielded trays are employed to receive fuzes removed from the grenades. The maximum number of fuzes allowed at each disassembly station may not exceed fifty.

(c) Fuzes which will not readily disassemble from the grenade with the equipment adjusted to the appropriate torque are immediately removed from the holding fixture and transferred to adequately shielded locations where they may be removed in accordance with the requirements contained in b above. Fuzes in this category will be inspected for any defects which would render the item unsafe for handling or further processing.

(d) Disassembly operations.

(7) Each disassembly operation will be separated from adjacent similar or dissimilar operations by operational shields designed to protect the operator at any operation from the blast and fragments arising from a possible explosion at any adjacent operation. Components will be protected from a possible explosion occurring at the disassembly operation.

(8) When disassembly of ammunition or components not generally included in paragraph 18-3 is contemplated, specific approval of the proposed methods and locations for the operations must be obtained in accordance with the procedures outlined in paragraph 2-8.

(9) When disassembly is required to be performed with the operator protected by any operational shield [disassembly means complete separation (threads or other connections) of component parts], the operator must not loosen the components while shielded and then complete the disassembly without protection.

*d. Containers for waste explosives.* Explosives destined for the burning ground will be in the original closed packages or in containers of fire-retardant materials which will not contribute to the existing hazard by readily producing sparks when contacting rocks, steel, or other containers. Bags or containers made from easily ignited material will not be used. Containers will have closures that will prevent spilling or leakage of contents when handled or if overturned. Closures will be of a type that will not pinch or rub explosives during closing and opening. The



closures and surfaces of container openings will be thoroughly cleaned of explosive contamination to minimize the hazard during closing or opening.

#### **14-4. Equipment for shielded operations**

As used in this paragraph, the word “suitable” refers to a certified or tested item. Normally, the equipment required for shielded operations consists of a suitable shield, holding devices, operating device, means of observing the operation, and means of safely transmitting power required for the operation.

*a.* A suitable holding device, located behind the operational shield may consist of some form of a vise or jig on either a fixed or an adjustable base, placed in such a manner as to hold the item in a position to apply the operating device.

*b.* A suitable operating device may be a wrench, screwdriver, or other tool designed to accomplish the work to be performed.

*c.* A suitable means for observation may be an indirect viewing system of mirrors or a television camera located so that personnel may operate at a safe distance. (A safe distance provides 2.3 pounds per square inch (PSI) protection to the operator.)

*d.* A suitable means of transmitting power to the operating device normally consists of a shaft extending through the shield. The shaft will have a positive stop in front of the shield to prevent the shaft from being blown through the shield toward the operator in the event of an explosion. Personnel will not be in a direct line with a shaft.

#### **14-5. Tools, equipment, and supplies**

*a. Tools.* The basic tools and equipment for Ammunition Renovation and Field Maintenance are listed in SC 4925-95-CL-A03. Specific tools for ammunition operations are listed in the applicable TM.

*b. Equipment.*

(1) Equipment that is designed specifically for ammunition is listed in TM 43-0001-47 and described in the operational and parts manual for each piece of equipment. Additional lists may be found in TM 9-1300-250.

(2) Other tools and equipment that have to be specially designed will meet strength requirements and guard against the introduction of chemical, mechanical, or electrical hazards over and above the normal hazard of the ammunition and explosives involved. Special tools and equipment, designed and fabricated locally, will require prior approval by the appropriate commodity command before use.

#### **14-6. Protection of primers**

Preventative measures must be taken in the design of equipment, transportation, and operations to protect not only loose primers but also primers in rounds or in components from accidental impact or pressure. Where feasible, a protecting cap will be placed over the primer. Bodies of hand trucks and other conveyances used for transporting the primed items must be free from stones, protruding nails, and other projections and debris that might cause the primer to function. When primed items are transported on their bases, the containers or truck bed will be recessed at the point primers would otherwise make contact.

#### **14-7. Cleaning ammunition**

Power tools with nonferrous brushes may be used on ammunition or ammunition components only when there are no exposed explosives or thin walled casings where brushing would create heat or friction sufficient to initiate the item involved.

#### **14-8. Spray painting**

*a.* All spray painting operations involving flammable liquids will comply with 29 CFR 1910.107, NFPA 33, and/or NFPA 77, whichever is more restrictive.

*b.* Water wash or dry filter-type spray booths will be used exclusively for loaded ammunition and inert items. Filters for dry type booths must not support combustion when clean and must be capable of effectively arresting paint overspray. They must be replaced whenever the type of paint being sprayed is changed, and as directed to maintain required airflow measures. Paint encrusted filters will be disposed of promptly when found.

*c.* Electrical equipment, devices, apparatus and wiring will comply with the requirements of Article 516, Spray Applications, Dipping, and Coating Processes, NFPA 70, and the National Electrical Code (NEC). Equipment will also be listed for the appropriate hazardous location as determined by use of Article 500, Hazardous (Classified) Locations, of the NEC.

*d.* Automatic sprinkler protection will be provided as follows:

(1) Above each paint booth and 20 feet horizontally beyond the perimeter of the paint booth.

(2) Installed in exhaust ducts, 6 feet or more in length. If the ducts pass through combustible walls, ceilings, or roof structures, the sprinkler heads inside the ducts, will be no more than 12 feet apart.

(3) For dry-type paint booths, automatic sprinklers will be installed behind the filters.

*e.* Controls for paint spray booth ventilating fan motors will be interlocked with the controls for the paint sprayer. With this arrangement, failure of the ventilating system will shut off power to the paint sprayer.

*f.* For additional paint booth and flammable storage requirements, see NFPA 33.

*g.* Where it is necessary to set up field operations and the requirements of a above, cannot be met, spray painting of sizable quantities of loaded ammunition or inert items is permissible if:—

(1) Paint booths are constructed of noncombustible material.

(2) An exhaust system with fan is installed to remove paint fumes from the booth (the fan may be powered by an air motor).

(3) At least two 10BC (or larger) CO<sub>2</sub> or foam-type extinguishers are installed within the booth with rate-of-rise actuated nozzle attachments. Two manual type CO<sub>2</sub> or foam-type portable fire extinguishers must also be provided at the paint spray booth or operation.

(4) Special precautions are taken to keep the booth clean and prevent the accumulation of paint on the surface of the booth or fire extinguisher nozzles.

(5) The number of items in the booth at any one time is restricted to the minimum number required for efficient and continuous operation.

(6) The area within 50 feet of the paint booth is kept free of combustible material, such as dry vegetation, wooden pallets, combustible crating, or packing materials.

(7) Paint and chemical mixing operations, supplies, and air compressors are located at least 50 feet from the booth.

(8) Personnel limits are maintained at the minimum consistent with efficient safe operation.

*h.* If the quantity of loaded ammunition or inert items to be spray painted in an outside location does not warrant providing a paint booth, the operation may be performed in the open provided:

(1) The area within 50 feet of the spray paint operation is kept clean and free from extraneous combustible material, air compressors, and paint mixing operations.

(2) At least two class 10BC (or larger) portable fire extinguishers are provided at the spray painting operation.

(3) Personnel are protected from toxic materials by respirators, approved for the amount and type of exposure involved.

(4) Personnel limits are maintained at the minimum required for efficient safe operation.

#### **14-9. Electrostatic paint spraying and detearing of inert items in nonhazardous locations**

*a.* Electrostatic paint spraying and detearing operations will meet the requirements of 29 CFR 1910.107, NFPA 33, and/or NFPA 77, whichever is more restrictive.

*b.* Loaded ammunition items will not be electrostatically spray painted or deteared.

#### **14-10. Infrared ray drying**

*a.* Infrared drying processes will not be used in the same room in which exposed explosives are present. Special precautions will be taken to ensure that all items from which explosives have been removed by processes such as “steam out” are free of explosives contamination before subjecting them to this process.

*b.* If sealed items containing explosives are to be subjected to infrared drying processes, prior tests to determine maximum internal temperatures to which explosives will be raised by such rays will be conducted on duplicate sealed containers with inert filler having a thermal conductivity and specific heat similar to that of the explosives. Conveyor speed, time of exposure, and intensity of exposure to infrared rays will be adjusted so that the maximum internal temperatures to which explosives are subjected to do not exceed 170 degrees F. (76.7 degrees C.) during entire period of exposure.

*c.* Before freshly dipped or painted items (inert or explosive loaded) are processed in infrared drying equipment, they will pass through a pre-dryer.

(1) This pre-dryer will be provided with positive mechanical ventilation, constructed of noncombustible materials, and will be provided with automatic sprinkler protection.

(2) The air exhausted from the pre-dryer will be discharged to the outside at a point where possibility of reentry into the building is at a minimum. The pre-dryer need not be heated. The time the article must remain therein will be determined by actual test when using the normal paint mixture.

(3) Freshly dipped or painted articles will be pre-dried until at least 85 percent of the volatile flammable vapors are removed. (In most instances, less than 2 minutes are required when air velocity past the article in the pre-dryer is 300 feet per minute (fpm) and the circulated air temperature is 70 degrees F.)

*d.* Within 20 feet of the pre-dryer, paint spray booth or dip tank, the electrical equipment will be installed in accordance with NFPA Standard 33.

*e.* Interlock the drying equipment with the exhaust fan so that the drying equipment cannot function unless the fan and conveyor are operating.

*f.* Infrared drying equipment will be installed in a large room at least six times as large in unobstructed area as the area of the infrared drying equipment.

g. Adequate ventilation, preferably exhaust ventilation of the pre-dryer will be provided for the room to keep vapor air mixtures at least 25 percent below the lower explosives limit, and also below the health hazard threshold limit values. Periodic tests in the vicinity of the infrared drying equipment will be made with a flammable vapor indicator to ensure low vapor concentrations.

h. The construction of infrared drying equipment will be such that paint dripping from articles will not strike the lamps, reflectors or wiring.

i. The construction and position of the infrared drying equipment and conveyor equipment will be such that contact between articles and bulbs is not possible.

j. Provisions will be made so that items being processed cannot drop off the hooks and lodge in the dryer unnoticed. If the drying equipment is constructed so that falling articles will not pass completely through it, arrangements will be made to automatically stop the conveyor and extinguish the lights concurrently using suitable protective devices.

k. The infrared drying equipment will be screened, or the source of infrared radiation shielded so as to protect workers from prolonged or close exposure to radiation. If screening or shielding is not adequate to protect employees' eyes while working in the vicinity of the drying equipment, safety goggles with Nos. 1-1/2 to 3 shade lenses will be worn by those exposed.

#### **14-11. Drying freshly painted loaded ammunition**

a. Ovens in which freshly painted loaded ammunition is dried will comply with the requirements of 29 CFR or NFPA Standard 33, whichever is more restrictive.

b. In addition, the following requirements will be met:

(1) Automatic thermostatic controls will be arranged to stop the application of heat upon reaching a predetermined maximum temperature which will not exceed 170 degrees F. (76.7 degrees C.).

(2) The oven will be equipped with an automatic sprinkler system installed in conformity with the requirements of NFPA Standard 13. Automatic operation of the system may be accomplished by electrical heat-actuated devices provided they are approved for, and are installed in accordance with the requirements of Class I, Division 1, Group D hazardous locations as defined in the NEC and NFPA 70.

(3) Heating may be by hot air or other means as long as ammunition or explosives do not come in contact with coils, radiators, or heating elements.

(4) If a conveyor system is employed, provision will be made to shut off the heat supply automatically in the event of power failure to the conveyor.

(5) Electric drying units that are not approved for use in Class I hazardous locations, as defined in the NEC and NFPA 70, will be designed so that the atmosphere in the oven is kept below 25 percent of the lower explosives limit of the mixture of solvent vapors and air.

#### **14-12. Heat sealing equipment**

Electric heat sealing machines, used for sealing packages of uncased or exposed explosives, will be separated from all similar or dissimilar operations by an operational shield large enough to limit the effect of an incident originating at the sealing operation to the immediate vicinity. This does not apply for sealing outer packages of cased or unexposed ammunition and explosives. Temperature limits for heat-sealing equipment will be established with a safety factor below the ignition temperature of the explosive, propellants, or pyrotechnics involved. Such sealing equipment will be limited to one machine per operating room, bay, or cubicle.

#### **14-13. Soldering containers**

Containers to be soldered will be free from explosives, explosive dust, and flammable vapors. This does not prohibit soldering covers to metal liners containing completely closed ammunition.

#### **14-14. Thread cleaning**

a. When thread cleaning is necessary, it will be accomplished by the judicious use of nonferrous "picks."

(1) Stainless steel brushes may be used to clean threads of explosive-loaded projectiles providing a fuze seat liner separates the thread cleaning operation from the explosive charge. Operational shields are not required.

(2) Power actuated "thread-chasing" tools may be used to clean loaded projectiles when threads are imperfect because of previously applied Pettman cement or other sealers, provided the operation is performed within a separate cubicle and by remote control.

(3) Hand operated "thread-chasing" tools may be utilized provided no explosives are present in the threads.

b. Thread cutting or correcting crossed threads will not be performed on projectiles containing explosives. Straightening of crossed threads is considered thread cutting.

#### **14-15. Inert scrap components and packaging materials**

a. All scrap components and packaging materials derived from ammunition and hazardous chemical renovation, P&P, modification and demilitarization operations will be inspected by the activity generating the scrap to detect

contamination. All packaging materials will be opened to ensure that no hazardous chemicals or ammunition items are present. Qualified responsible personnel will certify such material to be inert and free of hazardous chemicals and explosives prior to reuse or transfer to the Defense Reutilization and Marketing Office (DRMO) or to an inert storage area.

*b.* For those items transferred to DRMO, the qualified responsible personnel conducting the inspection of material will submit a certificate of inertness as part of the turn-in document in accordance with the provision of DOD 4160.21-M-1, chapter II, paragraph D2. Materials generated from ammunition or other hazardous items, even though properly inspected and certified inert, will not be mingled with other types of material, including scrap. The separation of inert projectiles, dummy ammunition rounds and other types of material will be maintained. See also DODI 4140.62 for guidance concerning MPPEH.

#### **14-16. Sand or shot blasting operations**

*a.* Because of possible hazards (resulting from hidden explosives, thin or eroded cases, and certain characteristics of explosive filler), sandblasting or shot blasting is prohibited for items such as thin-cased land mines, shoulder-fired rocket ammunition, fixed rounds of artillery ammunition, and cartridge cases containing propellant. Blast cleaning of solid propellant rocket motors may be accomplished only if the item manager approves in advance.

*b.* Explosive-filled or chemical-filled ammunition items assembled with tracers, fuzes, or other explosive-loaded components, which are not or cannot be adequately protected from direct contact with the abrasive, will have such components removed prior to blast cleaning. Where explosive-filled and chemical-filled items containing explosive-loaded components such as fuzes are, or can be, protected in a manner to permit blast cleaning, satisfactory safeguards must be installed to prevent rotational velocities and accelerations that will harm or otherwise affect the component parts.

*c.* In instances where items of ammunition are contained within a structurally suitable outer container, the container, if necessary, may be cleaned by sandblasting or shot blasting.

*d.* Each explosives or chemical-filled item must be carefully inspected for the presence of exuding explosives, chemical, and/or inert seal material prior to sand or shot blasting. If exudation can be properly removed with the application of approved solvents, such as acetone, the unit may then be returned for sandblast or shot blast cleaning. Solvents shall only be used in well ventilated areas.

*e.* All metal processing equipment used at the sand or shot blasting operations will be electrically grounded and tested.

*f.* All operators directly engaged in sand or shot blasting operations will wear personal protective equipment.

*g.* The quantity of loaded items being sand or shot blasted at one time will be maintained at the minimum consistent with safety and efficiency. The sand or shot blasting equipment location will be separated from the remainder of the operations and personnel by an adequate barrier, dividing wall, or appropriate QD in a manner to effectively limit the forces of an explosion during the process to the immediate area.

*h.* Steel wool will not be used for cleaning where possible contact with exposed explosives exists; nonferrous wool will be substituted in these instances.

*i.* Operations involving the processing of related inert components will not be performed in close proximity to the sand or shot blasting operation involving explosives-filled items. These operations will be accomplished at a location where safety from an explosion can be reasonably ensured. Wherever practical, the independent processing on inert components such as cleaning metal grommets and the like will be accomplished at not less than the appropriate ILD separation from the explosive hazard.

#### **14-17. Location of sand or shot blasting operations in explosives storage areas**

*a.* Inhabited building distance will be maintained from an earth-covered magazine or open storage site to the point of operation, when the point of operation is other than a permanent or semi-permanent structure.

(1) Permanent or semi-permanent structures for such operations will be located at a minimum of IBD from explosives storage locations, based on the larger quantity of explosives involved.

(2) Operations located at less than 100 feet from an earth-covered magazine or open storage site containing ammunition or explosives are prohibited under any circumstances.

(3) Where loading docks or other outdoor areas are used for sand and shot blast cleaning activity, unrelated concurrent operations will not be conducted in magazines or outdoor storage sites located closer than ILD.

*b.* A temporary earth barricade or other suitable protective barrier will be erected around sand or shot blasting operations conducted in the open within an ammunition storage area to protect adjacent personnel and the source of supply of explosive-filled items.

*c.* Air compressors and motor generator sets used at the operation are not to be located closer than 50 feet from the operational site and from the nearest earth-covered magazine or outdoor storage site. If they are gasoline-powered and are to be used for a period long enough to require refueling, they will be located 100 feet away, or midway between earth-covered magazines that are separated by 185 feet. Care must be exercised in the selection of the location to preclude exposure of the entrance to the operation or to the earth-covered magazine.

d. When it is necessary to use loading docks as operating sites for sand or shot blast cleaning operations, the docks will not be used for normal shipping and receiving activities.

#### **14–18. Sand or shot blasting operations within a building in an operating line**

When sand and shot blasting operations are carried on within a building in an operating line, the following safety measures are required in addition to the applicable precautions listed in paragraphs 14–16 and 14–17, above:

a. The actual sand or shot blasting operation must be separated from all other operations in the building by walls or barriers that are designed to protect all other personnel if an unusual incident occurs at this location.

(1) Opening in these walls or barriers will be limited to the minimum sizes required to facilitate the handling of items to and from the operation. These openings will be arranged in a manner to effectively baffle fragments and prevent projection into adjoining rooms.

(2) Openings of the size to allow entry and exit of MHE will not be permitted within the protective walls or barriers unless specially designed to provide resistance to potential explosions equivalent to that provided by the wall. A door opening of sufficient size for use of personnel only may be provided in the protective wall if required.

(3) In existing buildings where protection is provided by 12-inch reinforced concrete dividing wall, the wall must extend to the exterior walls of the building. In no event will the height of the concrete wall be lower than the lower rafters of the roof truss. Any opening remaining between the top of the concrete wall and the underside of the roof will be closed on both faces with rigid fire-resistant material securely fastened to the wall and the underside of the roof.

b. Equipment for sand or shot blasting operations will be of the type not requiring operators in the immediate vicinity of the machine to control it. It will be automatically controlled and provided with interlocking switches that will stop the machine if any of its parts fail. Manually controlled stop switches also will be provided at proper intervals to permit prompt stopping of the equipment in event of an accident. When manually operated abrasive equipment is used, “dead man” controls will be provided on the blast nozzle.

#### **14–19. Electrical testing of ammunition and ammunition components**

a. *Type of test equipment.* Electrical (including electronics) test equipment will use the weakest possible power source. Battery-powered equipment will be used in lieu of that with an alternating current (AC) source. The power source will not be capable of initiating the explosive item under test. Where greater power must be used, positive means must be provided to prevent delivery of power to the explosive item, in quantities sufficient to initiate the item. The possibility of error on the part of operators and other personnel must be recognized and safeguards provided.

b. *Layout of test equipment.* Test equipment will not be placed in hazardous atmospheres unless absolutely necessary. When the test equipment or parts thereof must be placed in hazardous atmospheres, its suitability must be attested by an approved testing facility’s approval or specific approval must be obtained from the commander.

(1) Unless the test equipment is incapable of initiating the item being tested, operational shields are required to protect personnel.

(2) The most reliable means for attaining and retaining this initiation incapability is to protect the test equipment, including leads, from electromagnetic (induction and radiation fields) and electrostatic energy and to provide the test equipment with a weak power source.

(3) Where reliance is placed on resistors and other devices for limiting power delivered to the item being tested, operational shields will be provided.

c. *Use of test equipment.* Test equipment will be used only in the manner and for the purpose for which approval was granted. The equipment will be maintained in good working order by qualified personnel. Operator adjustments must be limited to those required by design of the equipment.

d. *Equipment selection.* The Army equipment data sheets, ammunition peculiar equipment, TM 43–0001–47, may be used as a guide in selecting equipment for specific operations.

#### **14–20. Profile and alignment gaging operations**

a. Each profile and alignment gaging operation, excluding small arms ammunition, will be so enclosed that adjacent operations are protected by operational shields complying with the requirements of paragraph 14–3. The layout of the equipment and operational procedure will be developed with a view toward minimizing personnel injury and property damage in the event of an incident.

b. During chamber gaging of major caliber fixed ammunition, the gate will be pointed toward a dividing wall or other barrier and the round inserted into the gage and removed by the same operator. In no case will the round be left in the gage. Rounds of mortar ammunition will be gauged prior to attaching propellant increments, and, unless prohibited by design characteristics, prior to assembly of ignition cartridge.

#### **14–21. Collection of explosives dusts**

a. Dust collecting systems may be used to aid cleaning, to lessen explosion risks, and to minimize occupational diseases and dermatitis.

b. Examples of high explosives dusts which may be removed by a vacuum system are TNT, tetryl, Explosive D,

Composition B and pentolite. A wet collector which moistens the dust close to the point of origin and keeps it wet until the dust is removed for disposal is preferred except for Explosive D which will only be collected in a dry system.

*c.* More sensitive explosives such as black powder, lead azide, mercury fulminate, tracer, igniter, incendiary compositions, and pyrotechnic materials may be collected by vacuum, provided they are maintained wet with the wetting agent, close to the point of intake.

(1) The vacuum (aspirator) systems must be so arranged that the various types of explosives are collected separately or in a manner to avoid mixture of dissimilar risks; for example, black powder with lead azide.

(2) Provision will be made for the proper liberation of gases that may be formed.

(3) The use of vacuum systems for collecting these more sensitive materials will be confined to operations involving small quantities of explosives; for example, in operations involving fuzes, detonators, small arms ammunition, and black powder igniters.

(4) Potential fire and explosion hazards can be minimized by collecting scrap pyrotechnic, tracer, flare and similar mixtures in number 10 mineral oil.

*(a)* Satisfactory techniques include placing the oil in catch pans and scrap transporting containers at the various operations throughout the plant, and by having individual oil containers serve as collection points for multiple operations.

*(b)* In the latter case, nominal quantities of dry scrap may accumulate at operating locations before they are delivered to collection points and placed in containers of oil.

*(c)* The level of oil will be kept at least 1 inch above the level of any pyrotechnic mixture in the containers. Where oil is used, fire-fighting equipment satisfactory for class B fires will be available. Carbon dioxide or foam extinguishers are recommended.

(5) Containers in which scrap explosives and pyrotechnic materials have been collected will be removed from the operating buildings for burning at least once per shift.

#### **14–22. Location of collection chambers**

*a.* Wherever practical, dry type explosives dust collection chambers, except portable units as specifically provided for in paragraph 14–23, will be located outside operating buildings, in the open, or in buildings exclusively set aside for the purpose. To protect operating personnel from an incident involving the collection chamber:

(1) A protective barrier must be provided between the operating building and the outside location or separate building where the collection chamber is placed.

(2) If the collection chamber contains 25 pounds of explosives or less, the protective barrier may be a 12-inch reinforced concrete wall located a minimum of 8 feet away from the operating building.

(3) The collection chamber must be separated from cubicle walls by at least 3 feet.

(4) If the collection chamber contains more than 25 pounds of explosives and is separated from the operating building by a 12-inch reinforced concrete wall, the wall must be separated from the operating building by a minimum of IL(U) distance.

(5) If the protective barrier meets the requirements of paragraph 14–3 for operational shields (including the required 3-foot distance between the barrier and explosives), for the quantity of explosive in the collection chamber, or if they comply with the requirements of paragraph 14–29 for barricades, the cubicle may be placed at a minimum of IL(B) distance from the operating building. Barricaded and unbarricaded ILD will be based on the quantity of explosives in the collection chamber.

*b.* When it is not practical to locate dry type collection chambers outside the operating building, a separate room within the building may be set aside for the purpose. This room will not contain other operations nor will it be used as a communicating corridor or passageway between other operating locations within the building when explosives are being collected. Walls separating the room from other portions of the operating buildings must meet the requirements of paragraph 14–3 and not more than one collection chamber will be in a single cubicle.

*c.* Stationary and portable wet type collectors may be placed in the explosives operating bays or cubicles provided the quantity of explosives in the collectors does not exceed 5 pounds.

(1) If placed in separate cubicles, the explosives limits for the collectors may be increased to the amount reflecting the capabilities of the cubicle walls as operational shields.

(2) For greater quantities, the location requirements set forth in this paragraph are applicable.

#### **14–23. Design and operation of collection systems**

*a.* Collection systems and chambers will be designed to—

(1) Prevent pinching explosives (especially dust or thin layers) between metal parts.

(2) Pipes or tubes through which dusts are conveyed will have flanged, welded, or rubber connections. Threaded connections are prohibited.

(3) The systems will be designed to minimize accumulation of explosives dusts in parts other than the collection chamber.

(4) Accordingly, pipes or ducts through which high explosives are conveyed will have long radius bends with a center line radius at least four times the diameter of ducts or pipes. Short radius bends may be used in systems for propellant powder provided they are stainless steel, with polished interiors.

(5) The number of points of application of vacuum will be kept to a minimum. As far as practical, each collection system serving one bay will require a single header leading directly to the collector. A common header serving more than two bays is prohibited.

(6) No part of a collection system servicing an operation within a bay or cubicle will expose personnel outside that bay or cubicle.

(7) Wet primary collectors are preferred. Not more than two primary collectors (wet or dry) will be connected to a single secondary collector.

(8) If an operation does not create a dust concentration which may produce a severe health hazard, manual operation of the suction hose to remove explosives dusts is preferred to a permanent attachment to the explosive dust producing machine. A permanent attachment increases the likelihood of propagation through a collection system of a detonation occurring at the machine.

(9) Interconnection of manually operated hose connections to explosives dust-producing machines will be avoided.

b. Two collection chambers will be installed in series ahead of the pump or exhauster to prevent explosives from entering the vacuum producer in dry vacuum collection systems.

c. Dry portable vacuum collectors will not be located in a bay or cubicle where explosives are present, or in enclosed ramps, but may be positioned outside the buildings or in a separate cubicle having substantial dividing walls for quantities of explosives not exceeding 5 pounds.

d. Wet portable vacuum collectors may be placed in explosives operating bays or cubicles provided the quantity of explosives in the collector is limited in accordance with the requirements of paragraph 14–22.

e. For dry collection of quantities in excess of 5 pounds, or wet collection of quantities in excess of 15 pounds, the further provisions of paragraph 14–22 will apply.

f. The design of wet collectors will—

(1) Provide for proper immersion of explosives.

(2) Break up air bubbles to release airborne particles.

(3) Remove moisture from the air before it leaves the collector.

(4) Prevent moistened particles of explosives from entering the small piping between the collector and the exhauster or pump.

g. Explosives dust will be removed periodically from the collector chamber to eliminate unnecessary and hazardous concentrations of explosives but not less frequently than once every shift. The entire system will be cleaned, dismantling the parts if necessary.

h. Slide valves for vacuum collection systems are permitted. There will be no metal-to-metal contacts with the metal slide. An aluminum slide operating between two ebonite space bars will not constitute a hazard.

#### **14–24. Solid propellant collection**

a. Solid propellant being recovered from the fixed rounds that are being pulled apart will be removed from the pull-apart machine as soon as practical. This removal is best accomplished by a properly designed vacuum-type collecting system. Regardless of which type collection system is used, the operations and equipment will be arranged so that the operators and the pull-apart machine are not exposed to more than 15 pounds of solid propellants at any one time. If a vacuum collection system is not used, requirements of paragraph 14–24e below, must be enforced.

b. Vacuum collecting systems for solid propellants will be designed, located, and operated in accordance with the requirements of paragraphs 14–22 and 14–23, and where practical, will include wet collection features.

c. The common header connected to a primary collector will not serve, nor be connected to, more than three pull-apart machines. Not more than one header connected to a collector will be operated simultaneously. Additional collecting units will be installed complete for any additional pull-apart machines, limiting each additional collecting system to not more than three machines.

d. Pull-apart machines will be electrically interconnected with vacuum collection systems (piping and collectors) and grounded.

e. When vacuum collecting systems are not installed, the collection of solid propellants may be accomplished by means of a closed tube or chute leading from the pull-apart machine to a collection point located in a separate room or enclosure.

(1) This system depends on unimpeded gravity flow. Each tube or chute will be equipped with a properly designed flashback damper to prevent exposure of personnel to flame, toxic gas, and heat in the event of an incident within the collection station.

(2) The tubes, troughs, and containers at the collection station will be of non-sparking metal properly cross bonded and electrically grounded.

(3) The collection station enclosure or room will be vented directly to the outside (preferably through the roof) to prevent the rupture of the room or enclosures.

(4) The total poundage of solid propellants at the collection station will be limited to a minimum amount necessary to fill one container (not over 200 pounds).

#### **14-25. Destruction of solid wastes**

Contaminated solid waste material will be taken in closed containers, as soon as practical, to buildings set apart for its treatment or to the burning ground to be destroyed in an appropriate manner.

#### **14-26. Assembly and crimping of complete rounds**

Each assembly and crimping machine will be separated from other similar or dissimilar operations by walls or operational shields that are sufficiently strong to retain any fragment that may be produced.

#### **14-27. Rotational speeds for equipment used in field ammunition operations**

*a.* The following rotational speeds will be the maximum permitted for equipment used in ammunition field operations:

(1) Drilling exposed explosives, 75 revolutions per minute.

(2) Cleaning metal parts seated in explosives, such as fuze seat liners in projectiles and bombs, 125 revolutions per minute.

*b.* The speeds cited above are applied speeds of light feed. Rotational speeds for equipment used in explosives loading are set forth in paragraph 14-28. Higher speeds and rates of feed are permitted for these because of their mechanical tool alignment and speed and feed control features. Stainless steel brushes may be used for cleaning small deposits of explosives from nose threads of separate loading projectiles provided brushes have been proven to be non-sparking and have speeds and feed in accordance with the standards above.

*c.* Rotational speeds and other safety factors for equipment used in machining explosives in workshops or line operations are contained in paragraph 14-28.

#### **14-28. Machining of explosives**

*a.* Items containing explosives may be drilled either while in a vertical or horizontal position. Vertical drilling is preferred since withdrawal of explosive chips and dust is facilitated and proper drill alignment is more easily attained and maintained.

*b.* To protect adjacent operators, high explosives will be drilled, faced, milled, sawed, or otherwise machined within rooms or cubicles having reinforced concrete walls except as permitted by paragraph 14-28.

(1) The following high explosives, cased or uncased, may be machined without protection for the operator and without coolant if there is no metal-to-metal contact: Amatol, Octol, TNT, Composition B, Explosive D, and RDX/TNT compositions containing 60 percent or less RDX.

(2) The following high explosives, cased or uncased, may be machined without protection being afforded the operator provided a suitable noncombustible, nontoxic coolant is directed on the tool and explosives at their point of contact: baratols, pentolite (50-50 and 10-90), tetrytol, and cyclotols (Composition B less than 60-40; that is 70-30).

(3) When essential, any other high explosives may be machined by remote control, with the operator protected by a suitable operational shield (see para 14-29). Initiating explosives will not be machined if other means (for example, forming) may be used to obtain desired shapes or sizes. If a coolant is used when machining explosives containing aluminum, it must be of a waterless, noncombustible, and nontoxic type.

*c.* If drilling is being accomplished without protection for the operator, only a single drill will be used and the drill must have a diameter greater than one-fourth inch. Operations involving the use of multiple drills or drills one-fourth inch or less in diameter must be performed by remote control, with the operator protected by an operational shield.

*d.* Machining of cased explosives is permitted, if the operation requires the tool to remove metal prior to or after contact with the explosives filler, provided it is performed by remote control with the operators protected by operational shields complying with the requirements of paragraph 18-29.

*e.* Where wet machining is to be performed, positive automatic interlocking devices will be provided to ensure that machining cannot be started until coolant is flowing. These controls also must be capable of stopping the machining if the flow of coolant is interrupted.

(1) When it is essential to cut off the flow of coolant to adjust machining tools, positive means must be devised to ensure that, when adjusted, the flow of coolant is restored and all automatic control devices are in operation before machining is permitted to continue.

(2) The manipulation of the manual means employed for making the automatic control devices temporarily inoperative will be under the direct control of some assigned, responsible person other than the operator.

*f.* The lineal and rotational speeds of tools used for the machining of cased or uncased explosives will be maintained at the minimum necessary to safely and efficiently perform the operation. Speeds will not exceed 210 linear fpm or 525



revolutions per minute. So far as practical, machining equipment will be used that is capable of accurately controlling the rate of feed. The above rotational and feed speed rates are for high explosive charge machining.

(1) For propellant manufacture, machining rates and methods will be established for individual operations by accepted hazard analysis methods. The rate of feed used will be the lowest consistent with safe and efficient operations, dependent upon the explosive materials being machined.

(2) When equipment provided with feed control mechanisms are used for machining high explosives, the rate of feed used will not exceed .035 inch per revolution.

(3) Cavities required in explosives preferably will be made with forming tools rather than drills.

*g.* Pneumatic or hydraulic driven machine tools are preferred for all machining operations on high explosives. Electric tools may be used if the motors, switches, and wiring are of types suitable for the specific hazardous exposure being produced. Control mechanisms for hydraulic or pneumatic equipment will provide positive control of speed selected to prevent tampering by unauthorized personnel. Pressure relief devices will be installed where necessary.

*h.* Wherever practical, and when forming tools cannot be used, “fly-cutter” type tools and forming cutters will be used for producing cavities in high explosives. When fluted drills must be used, the flutes will extend from the tip of the drill to a point beyond the entry of the drill into the cased or uncased explosives. High explosives will not be drilled to a greater depth than 4 inches unless operation is remotely controlled or the drill is stopped at increments of depth not greater than 4 inches, withdrawn, and loose explosives removed from the cavity and drill before continuing. When producing cavities in high explosives with a “fly-cutter” type drill, a flow of air will be directed at or near the interior bottom of the cavity to aid in clearing explosives chips and dust through the exhaust systems.

*i.* In all machining operations on cased or uncased high explosives, tool adjustments will be controlled by positive means to ensure proper depth, diameter and contour of the cut. The positive control measures will include guides, bushings or other alignment aids to prevent contact between moving parts of the machining equipment and metallic parts of the case or holding fixtures. Minor adjustments of machining tools may be made while operations are in progress; however, the total personnel exposure must not exceed that permitted for normal operation. Major repairs, modification, or adjustment of machine equipment will not be undertaken while machining of explosives is in progress.

*j.* Dull or damaged tools will not be used for machining high explosives. Tools will be made of material which will take and retain a satisfactory cutting edge and be compatible with the explosives being processed.

*k.* The explosives products resulting from drilling and other machining operations will be removed by an approved exhaust system or by immersion in a stream of water flowing away from the operation.

(1) The waste products will be collected at a point outside the operating room or cubicle. Collected waste products will be removed from the operating area at intervals frequent enough to prevent hazardous accumulations.

(2) The use of large capacity sumps immediately adjacent to the operating room or cubicle will be discouraged.

*l.* The quantity of cased or uncased explosives being machined will be the minimum necessary for safe and efficient operation. When the explosives intended for processing are on trays or transfer dollies, the unit being processed must be located as far as is practical from the remaining units a waiting processing.

*m.* Unless an operational shield is provided to protect operators, not more than two persons will be permitted in a room or cubicle when dry machining of explosives is being accomplished. Where wet machining of explosives is being performed and the work is of a special nature which requires the presence of more than two persons, the number of personnel exposed will not exceed five.

#### **14–29. Operational shields for munitions loading**

*a.* Operational shield for munitions loading operations will comply with the requirements of paragraph 14–3.

*b.* On any equipment used for explosives processing, equipped with doors which function as operational shields, interlocking devices will be installed which will prevent the operator from opening such doors while the equipment is in operation.

## **Chapter 15 Demilitarization**

### **15–1. Demilitarization**

*a.* This chapter covers demilitarization operations to include demolition and burning operations done as a separate operation. It does not cover EOD operations or operations involving toxic chemical munitions. It does not cover demolition and burning operations done as part of a training exercise providing that—

*b.* The item to be destroyed was generated during training.

*c.* The item would normally be destroyed as part of the wartime mission.

*d.* The item has not been returned to storage.

## 15-2. Methods

Disposition of ammunition, explosives, and propellants will be accomplished by reclamation, open detonation (OD), open burning (OB), incineration, or other approved methods. Unless emergency disposition is required, resource recovery and recycling efforts will be the primary means of disposing of unwanted ammunition and explosive materials. The burying or dumping of ammunition, explosives, or propellants is not an approved method of disposal.

## 15-3. Safety precautions

*a. General precautions.* No demilitarization operation will take place without an approved SOP. The SOPs used for these types of operations will be reviewed at the local level at least annually for compliance with local laws and regulations involving demilitarization. The SOPs that are not in continuous use and have not been used within the past 6 months will be reviewed and updated before the beginning of an operation.

*b. Burning/detonation operations.*

(1) A red range flag will be flown or a red light will be lit at the entrance to the range when operations are in progress. A red light will be used during any operations occurring after sunset.

(a) The flag will be a minimum of 3 feet wide by 5 feet long. This flag will continue flying until the range has been cleared and all operations have ceased.

(b) The light will be of sufficient size and clarity to be seen from at least 100 feet under all weather conditions in which operations take place. This light will continue to burn until the range has been cleared and all operations have ceased.

(2) A sign will be placed on the access road to the range explaining the meaning of the red light and red flag. This sign will be located at least 100 feet from the gate and will be lighted during night operations. This sign will be in English and foreign languages required by the area.

(3) A first aid kit will be present during all operations. It will contain, as a minimum, items to treat burns and puncture wounds. Local medical authorities will approve the first aid kit based on the risks involved. Personnel will be trained in using the first aid kit and its limitations. They will be instructed that if there is any doubt as to its use, that they will seek professional medical care for the injured person.

(4) A means of communications between personnel on the demolition range or burning area and base facilities will be maintained in working order. A further means of communications will be maintained between personnel preparing items for demolition or burning operation and the control center on the range. Operations will not be conducted if one or both of these means of communications is not working. Radios will not be used when electrically initiated explosives are being used, unless in compliance with table 17-3.

(5) Firefighting equipment will be present at the scene to combat fires that may start due to operations. The amount and type of equipment will vary with local conditions and will be approved by the garrison or installation fire marshal.

(6) After each demolition or burning operation, trained and competent personnel will search the area for hazardous items. The search will begin after an appropriate waiting period as specified in the SOP for the operation. Personnel will be instructed in the type and shape of the items being destroyed as well as what to do upon finding an item. In the event of a misfire, a waiting period of at least 60 minutes will be observed prior to investigating the misfire.

(7) In areas where the demolition ranges or burning grounds are not under constant control of U.S. military, the following requirements will be strictly adhered to:

(a) Before the start of operations, the range will be searched for unauthorized personnel.

(b) Guards will be posted to prevent entry into the range area. Guards will be protected from fragments.

(8) All personnel shelters will protect against overpressures greater than 2.3 psi and against noise louder than 140 decibels if the noise level exceeds 140 decibels. Personnel will wear hearing protection in accordance with DA Pam 40-501. If the noise level is greater than 165 decibels, then earplugs must be worn in combination with a noise muff or a noise attenuating helmet.

(9) All burning and demolition operations will be initiated remotely or by using a delay device. If a delay device is used, it must allow for a delay that is 50 percent longer than the time that would normally be required to retire to the shelter.

## 15-4. Site selection for burning or demolition grounds

*a. Open burning and open detonation areas.* OD operation and sites for burning of ammunition and explosives shall be separated from other facilities as specified in paragraph 8-29 and paragraph 6-8.

*b. Burning and demolition sites.* All disposal sites permitted as hazardous waste treatment facilities under 40 CFR must be sited in accordance with 40 CFR 265.382.

## 15-5. Burning sites

*a.* Burning pans or trays will be of locally approved construction and appropriately grounded.

*b.* Burning pads constructed of concrete will be covered with a minimum of a 4-inch bed sand to protect the concrete. When the user intends to dispose of the sand, tests for hazardous waste characteristics will be conducted.

c. All burning sites will have a means of collecting remnants and eventually disposing of any hazardous wastes produced by the operation.

d. Burning sites will—

(1) Ensure that the items to be burned are spread evenly over the burning pan or pad, so that the depth of the material does not exceed 3 inches. Items which exceed 3 inches in diameter may be burned, provided they are stacked only one item high.

(2) Be sited so that the distance between each active burning site will be sufficient to prevent a burning ember from landing on adjoining sites.

e. Garrisons or installations must establish written procedures to prevent materials to be burned from igniting from heat or residue remaining in pan trays or on pads.

## **Chapter 16 Construction**

### **16–1. Construction considerations**

a. The primary objective of this section is to ensure design procedures and construction techniques used in siting explosives facilities provide the desired margin of protection for personnel, the environment and valuable material. The secondary objective is to ensure that explosives facilities and other related facilities are constructed in a way that will maximize cost-effectiveness in both planning and facility utilization.

b. Use TM 5–1300 in selecting and designing explosives facilities.

c. By using the standards and guidelines provided in the TM 5–1300, organizations can ensure that both of the above objectives are met. Managers must carefully evaluate their need for explosives facilities and ensure that construction techniques match mission requirements.

### **16–2. Buildings**

a. Construction features and location are important safety considerations in planning facilities that are to be a potential explosion site or exposed to the damaging effects of potential explosions, that is an exposed site. The effects of potential explosions may be altered significantly by construction features that limit the amount of explosives involved, attenuate the resulting blast overpressure or thermal radiation, and reduce the quantity and range of hazardous fragments and debris. Proper location of exposed sites in relation to a potential explosion site ensures against unacceptable damage and injuries in the event of an incident.

b. The primary objective of an earth-covered magazine is to provide protection for its assets. To qualify for the default IMDs in table 8–15, a magazine must not collapse when exposed to an accidental explosion and resulting overpressures. The magazine may flex, but these deformations should take place and be limited to the air gap around the ammunition and explosives in the magazine. The deformed magazine or its door should not strike the ammunition or explosives.

c. There are three types of earth-covered magazines. Each type corresponds to certain construction criteria and has headwalls and doors designed to withstand certain overpressures. These types are:

(1) Magazines with headwall and blast door hardness of '7–Bar' are designed to withstand overpressures of 100 psi.

(2) Magazines with headwall and blast door hardness of '3–Bar' are designed to withstand overpressures of 45 psi.

(3) Undefined magazines are magazines without reinforced concrete headwalls and are expected to offer the least resistance to overpressure.

d. The arch of an arch shaped magazine needs to be designed to support conventional dead loads. The roof of a flat roofed magazine must be designed for both dead loads and dynamic blast induced loads. The side and rear walls of earth-covered magazines need only be designed to support conventional loads.

e. Each magazine will be provided with appropriate means of air circulation or dehumidification.

f. Each magazine will be provided with appropriate means of lightning protection in accordance with paragraph 17–16, Section V.

g. For buildings that will contain ammunition and explosives, the roof and walls should be as light in weight and as weak as practical. This does not apply to buildings or rooms which are built for containment or protection. Most buildings should be constructed and supported to allow the venting of an internal explosion, with the minimum number of large fragments. Exceptions are made where design requirements such as the following must be met:

(1) Fire walls.

(2) Substantial dividing walls.

(3) Special roof loadings.

(4) External overpressure protection.

(5) Specified manufacturing facilities.

*h.* A list of magazines currently approved for construction can be found in appendix G or in DDESB Technical Paper 15.

### **16-3. Interior finishes and floors**

*a.* Noncombustible material will be used for interior surfaces of buildings.

(1) Where hazardous locations (see para 17-2) exist, interior surfaces should also be smooth, free from cracks and crevices, and with joints taped or sealed.

(2) If painted, the surfaces should be covered with a hard gloss paint that is easily cleaned. Horizontal ledges that might hold dust will be avoided or beveled. Cove bases at the junction of the walls and floor are recommended.

(3) If combustion-supporting materials are necessary in the interior of an operating building, treat or cover all exposed surfaces with fire retardant material.

*b.* Conductive non-sparking floors are required where certain exposed explosives and materials, sensitive (easily detonated or ignited) to the uncontrolled discharge of static electricity, are present.

*c.* Where washing is required, floors must be able to withstand repeated applications of hot water or other compatible cleaners.

### **16-4. Firewalls**

Firewalls are designed to limit the spread of fire. They should extend through the roof and walls of the buildings. If openings are required, they must be protected as described in the NFPA 80.

### **16-5. Building exits**

Exits and doors will conform to OSHA, NFPA 101, and NFPA 80, requirements.

### **16-6. Safety chutes**

Safety chutes will be provided as exits from multistoried, hazardous locations where rapid egress is vital and not otherwise possible.

### **16-7. Emergency exits and fire escapes**

Use the ANSI Safety Code A156.3, NFPA 101, and NFPA 80 as a guide in constructing emergency exits and fire escapes. All openings will be protected as required by NFPA 101.

### **16-8. Stairways**

Stairways will conform to OSHA requirements. Open risers (stairs without vertical members) should be avoided.

### **16-9. Fixed ladders**

Fixed ladders should conform to the ANSI Safety Code A14.3 and OSHA Std. 1910.27.

### **16-10. Platforms, runways, and railings**

Platforms, runways, and railings will conform to OSHA and NFPA requirements.

### **16-11. Passageways**

If weather-protected passageways (ramps) for communication between buildings or magazines are constructed, these passageways should be of noncombustible construction and should be provided with suitable fire doors to interrupt a fire in its progress through the passage; these provisions will be applied in new construction. To prevent funneling of explosion forces, weak sections, openings, and abrupt changes in direction should be incorporated in design and construction of passageways between explosives buildings.

### **16-12. Roads, walks, and gates**

*a.* Good all-weather roads should be provided to and within the explosives areas.

*b.* Only one gate in the fence around an explosives area is required. Planners will determine how many gates are needed after considering all elements of the situation (physical security, operations, explosives safety, fire protection, and so forth). Consideration should be given to providing an alternate personnel gate for emergency evacuation.

*c.* Road systems serving groups of magazines or explosives buildings will be arranged without dead ends so that motor vehicles carrying explosives cannot be isolated. To prevent dead ending, interconnecting roads for magazine service roads need only be passable trails adequate to accommodate the typical vehicles used at the garrison or installation.

*d.* Roads serving a single magazine or explosives processing building (including its service facilities) may dead end at the magazine or building. The road system should be designed to eliminate the need for passing through an intermediate explosives area in traveling from one area to another.

*e.* Walkways and roads at the entrances to or between adjacent operating buildings containing explosives will be hard surfaced or boardwalks. These walkways and roads should be kept free from foreign material. Foot brushes, door

mats, or scrapers should be provided at the entrance of each building, except magazines. Special attention will be given to passageways, walkways, and stairs which have been subjected to the effects of inclement weather.

### **16–13. Windows and skylights**

Overpressures that result from an explosion can cause standard window glass to break and form razor-sharp shards that can be projected inward at considerable velocity. Serious injuries to personnel can result from such fragments, even at distances where no significant effects from blast or other type fragments would occur. QD separation distances prescribed by this Pamphlet do not provide protection from glass hazards and associated risks and it is important that prudent measures be taken to minimize these risks. Accordingly, the following measures apply to structures and buildings that have continuous, frequent, or periodic personnel occupancy, either associated or not associated with ammunition operations (such as, administrative or field offices, surveillance workshops, and operating lines). These requirements do not apply to structures that have brief and transitory occupancy (for example, forklift charging stations, structures storing fire-fighting equipment, or other similar non-explosives storage locations).

*a. Skylights.* Skylights will not be used in buildings where ammunition or explosives are processed and should not be used in any personnel occupancy structure within K50 distance of a potential explosion site.

*b. New construction.*

(1) New construction will minimize or eliminate entirely the number of standard glass windows or reduce glass surface area to the absolute minimum in buildings or structures near a potential explosion site.

(2) Standard window glass will not be used within the IBD arcs of PESs. When windows are required for operational reasons, within the IBD arc, the following apply:

(a) The number and size of the windows will be minimized.

(b) Blast-resistant window glazing that precludes projection of glass fragments will be used.

1. An engineering analysis will be made to determine the type of blast-resistant glass required to withstand the expected overpressure and the placement of windows inside the exposed building for optimum personnel safety.

2. Window design need not be engineered to provide protection from overpressures exceeding 3.5 PSI (k18).

(c) Window placement on structures will, to the maximum extent possible, be designed so that the windows are situated away from a direct line-of-site exposure to any potential explosion site.

(d) The window frame and frame connection to the structure must be of sufficient strength to retain both the window glazing and the window frame within the structure when struck by the blast wave.

1. Window glazing can be designed to either fracture or not fracture.

2. Window glazing and frame should be designed to remain in the window frame or, as a minimum, simply fall out and land proximate to the structure.

3. New buildings will be designed and constructed using the standards and guidelines of TM 5–1300 or other approved engineering standards to withstand the maximum expected overpressure from an explosion at the potential explosion site. When using procedures of TM 5–1300, the thickness of the laminate in laminated glass will be determined from the design procedures and expected overpressures, but will be a minimum thickness of 0.030 inches.

4. Prior to construction of a new explosive facility, a glass breakage hazard risk assessment for all exposed sites within the IBD arc will be conducted and risks from glass breakage will be mitigated where feasible.

5. These requirements for new construction will be complied with upon a major modification of the construction features of the exposed building or when modifications to operations or explosives conditions at the potential explosion site significantly increase the risk to other exposed building.

*c. Existing exposed structures.* An assessment will be made of exposed sites within the IBD arc of each potential explosion site to determine if windows can be eliminated or the glass hazards mitigated. All feasible corrective actions should be taken. These may include;

(1) Replacement of standard glass windows, if possible, with blast resistant glass.

(2) The application of fragment retention films on window interiors (See paragraph d. below).

(3) Covering the inside of windows with 1/2 inch plywood and strengthening window frames.

(4) Installation of heavy curtains, blast curtains, or other similar shields to catch or impede glass shards (application of fragment retention film, minimum thickness of 4 mil - technically known as daylight application - used in conjunction with these curtains has been found to significantly increase the curtain's hazard-reducing effectiveness).

*d. Glass recommendations.*

(1) Standard window glass (annealed) easily breaks and forms dangerous shards. For new construction, standard glass will not be used out to K40–K50 distances (IBD). For existing exposed sites, use of standard window glass at distances less than K40–K50 distances (IBD) requires mitigating action as identified above.

(2) Thermally tempered glass, when broken, is less hazardous than annealed glass but can form small, sharp-edged cubes that can be projected with dangerous effect. For new construction, non-laminated thermally tempered glass will not be used out to K40–K50 distances (IBD). For existing exposed sites, use of non-laminated thermally tempered glass at distances less than K40–K50 distances (IBD) requires mitigating action as identified above.

(3) Laminated glass has a clear plastic adhesive sheet made of polyvinylbutural between layers of annealed, heat-

strengthened, or thermally tempered glass. Use of laminated glass is effective for minimizing projected fragments and is satisfactory for new construction.

(4) Polycarbonate glazes, used as commercial security glazing including bullet-resistant applications, are effective in resisting overpressure and are satisfactory for new construction.

(5) Fragment retention films are clear plastic films applied to the interior of windows that act like laminated glass. Use of fragment retention films is for retrofit application only and shall not be used for new construction. The film thickness shall be commensurate with the anticipated blast loading and determined using analytical procedures or test data. The film should be applied into the frame bite of the window or otherwise suitably secured. Fragment retention films have a 4–5 year shelf life. For additional information see U.S. Army Corps of Engineers Guide Specification CEGS-08850 (July 1992), Fragment Retention Films.

#### **16–14. Drains and sumps**

When drain lines are used for fluids containing explosives waste, they must have sumps or basins so that the waste explosives can be removed.

#### **16–15. Hardware**

*a.* To reduce the risk of accidental ignition by spark, the operational conditions in any hazardous location must be considered in the choice and installation of hardware. Certain risks may be great enough to warrant using materials that will reduce the possibility of sparking. Therefore, special precautions must be taken for hardware having metal components which is used around exposed explosives.

*b.* Hardware must be secured firmly in place with locking devices if it might become loose and enter into an explosives mix. This precaution is especially important in manufacturing and renovation operations.

*c.* Avoid installing hardware (including pipes and ducts) on light blowout-type walls and roofs. If it is necessary, select materials or items that will not yield heavy fragments in an explosion.

#### **16–16. Tunnels**

Tunnels must be drained, ventilated, well-lighted, and have at least two exits. Water and steam service lines in tunnels will be lagged with suitable insulation. Tunnels between buildings that contain explosives will be built to resist the shock wave and blast of an explosion. Only authorized personnel will enter the tunnels.

#### **16–17. Powerhouse equipment**

Powerhouse equipment, boilers, engines, and auxiliary equipment will be installed in compliance with the American Society of Mechanical Engineers (ASME), Boiler and Pressure Vessel Code (includes Code for Unfired Pressure Vessels), the NEC, and other codes, regulations, or standards accepted as standard good practice.

#### **16–18. Refrigeration**

Refrigeration equipment (including air conditioning) must be installed as required by the American Society of Heating, Refrigerating and Air Conditioning Engineers (ASHRAE) Standards 15, Safety Standards for Refrigeration Systems (available at <http://www.ashrae.org/catalog>).

#### **16–19. Laundries**

*a.* Laundries should have facilities for washing and flame-proofing uniforms if such clothing is used.

*b.* The facilities will include a safe place to store uniforms and rags that are contaminated with explosives before washing. Sumps will also be provided to remove explosives from waste water. There should be facilities available to test whether the contaminant (particularly any insoluble toxic substance) has been removed.

*c.* Commercial concerns laundering such articles will be informed of the nature of the explosives contamination and possible dangerous chemical reactions. These concerns should also have the facilities listed in paragraph 16–19*a*, above.

#### **16–20. Steam for processing and heating**

*a.* Steam used to heat operating buildings that contain explosives must never be hotter than 228 degrees Fahrenheit (F) (108.9 degrees Celsius (C)). Process steam may exceed this if necessary but will not exceed 249.5 degrees F (120.8 degrees C).

*b.* The exterior of steam or hot water pipes in contact with wood, paper or other combustible materials must never be hotter than 160 degrees F (71 degrees C). If the steam is hotter than this, the steam lines must be covered and painted with an impervious material or otherwise protected against contact with explosives.

*c.* Where electrical resistance to ground is high, steam or hot water lines should be grounded where they enter buildings. See chapter 17 for further guidance on bonding and grounding requirements.

## 16-21. Ventilation

*a.* Buildings where dust, fumes, or vapor are formed will be adequately ventilated, preferably at the source of the hazard. Air should not be recirculated through these ventilation systems.

*b.* Exhaust fans through which combustible dust or flammable vapor pass will be equipped with nonferrous blades (or casting lined with nonferrous material) and suitable motors. Exhaust systems will be cleaned thoroughly and serviced on a regular schedule. These actions will be noted in a log. The entire ventilating system will be bonded electrically and grounded properly. The NFPA standards may be used in the installation of such systems.

*c.* For buildings in which explosives dust is present, an air balance that gives a slight negative pressure within the building is required.

*d.* If using air-conditioning equipment, it should be installed as directed in the NFPA Standard 90A and Standard 90B.

## 16-22. Electrical equipment

The installation of electrical equipment within an explosives area (building, magazine, shelter, and so forth) will comply with the NFPA 70 as a minimum, unless specified otherwise (chapter 17).

## 16-23. Collection of explosives dusts

The high explosives dusts, which may be removed by a vacuum system, are TNT, tetryl, Explosive D, Composition B, and pentolite.

*a.* A wet collector which moistens the dust close to the point of origin and keeps it wet until it is removed for disposal is preferred. Explosive D should be collected in a dry system. More sensitive explosives (such as, black powder, lead azide, mercury fulminate, tracer, igniter, incendiary compositions, and pyrotechnic materials) may be kept wet, with a compatible wetting agent close to the point of intake.

(1) Vacuum (aspirator) systems must be arranged so that each type of explosive is collected separately or so dissimilar risks (for example, black powder with lead azide) are not mixed. Gases that may form must be properly liberated.

(2) Vacuum systems used to collect these more sensitive materials should be used only for operations with fuzes, detonators, small arms ammunition, and black powder igniters.

*b.* Dry explosives dust collection chambers, except as specifically provided for portable units, should be located outside operating buildings, in the open, or in buildings exclusively for the purpose.

(1) There must be a protective barrier between the operating building and the outside location or separate building containing the collection chamber.

(a) If the chamber contains 25 pounds of explosives or less, this barrier may be a substantial dividing wall located at least 8 feet from the operating building.

(b) If the chamber contains more than 25 pounds of explosives and is separated from the operating building by a 12-inch SDW, the wall must be separated from the operating building by a minimum of ILD.

(c) If the barrier meets the requirements for operational shields or barricades (for the quantity of explosives in the collection chamber), it will be at a minimum of IL(B) distance from the operating building.

(2) When it is not practical to locate dry collection chambers outside the operating building, a separate room within the building may be set aside for the purpose. This room must not contain other operations and may never be used as a communicating corridor or passageway between other operating locations within the building when explosives are being collected. If more than one collection chamber is to be placed in the room, the room will be subdivided into cubicles. Not more than one collection chamber will be in a single cubicle.

(3) Dry portable vacuum collectors will not be placed in a bay or cubicle where explosives are present. If they do not contain more than 5 pounds of explosives, they may be placed outside the building or in a separate cubicle having substantial dividing walls. If they contain more than 5 pounds, the requirement for stationary collectors will be met.

*c.* If stationary and portable wet-type collectors do not contain more than 5 pounds of explosives, they may be placed in operating bays or cubicles. If placed in separate cubicles, the limits for each one may be 15 pounds. If they contain more than 15 pounds, the location requirements for dry collectors will apply.

*d.* Collection systems and chambers will be designed so that metal parts do not pinch explosives or explosive dusts. Pipes or tubes through which the dust travels should have flanged, welded, or rubber connections. Threaded connections are not allowed. The system will be designed to reduce accumulation of explosives dust in parts other than the collection chamber.

(1) Long-radius turns (centerline radius at least four times the diameter of the duct) will be used in the duct work. Short-radius bends may be used in systems for propellant powder provided they are stainless steel with polished interiors. The number of points of application of vacuum should be kept to a minimum. Each room requiring vacuum collection should have a separate exhaust line to the primary collection chamber. Not more than two bays will be serviced by a common leader to the primary collection chamber. Wet primary collectors are preferred.

(2) The vacuum line should be as short as possible from points of application of vacuum to the wet collectors. The number of wet primary collectors serviced by a single secondary collector should be kept to a minimum. Not more than

two dry primary collectors should be connected to a single secondary collector (wet- or dry-type). If an operation does not create an airborne concentration of dust, a manually operated suction hose to remove explosives dust is preferred. A permanent attachment increases the risk of propagation through the collection system should a detonation occur at the dust-producing machine.

(3) Manually operated hoses should not be connected to explosives dust-producing machines. In dry vacuum collection systems, two collection chambers should be installed in series ahead of the pump or exhauster. Wet collectors must provide immersion of explosives to break up air bubbles, release airborne particles, and remove airborne moisture before it leaves the collector. This will keep moistened particles of explosives from entering the small piping between the collector and the exhauster or pump.

(4) Explosives dust will be removed from the collection chamber at least once each shift to eliminate unnecessary and hazardous concentrations of explosives. The entire system should be cleaned weekly, dismantling the parts if necessary.

(5) The entire explosives dust collection system will be electrically grounded and the grounds tested semiannually.

(6) Wet collection systems subject to freezing may be protected with antifreeze provided the antifreeze formula has been certified as compatible chemically with the propellant or explosives dust in use.

#### **16–24. Automatic sprinkler systems**

Certain buildings in explosives manufacturing, surveillance, and inspection or ammunition workshop areas (for example, the receiving building in a load line) may require automatic sprinkler systems. The proper system should be determined by engineering studies of the risks involved. Each system must be equipped with an audible warning device to alert personnel. Sprinkler systems in each building must be connected to the central alarm location. Sprinkler systems will be installed as prescribed in AR 420–1, NFPA 13, and NFPA 16.

#### **16–25. Barricades and earth cover for magazines**

*a. Barricading.* Properly constructed barricades or undisturbed natural earth are effective in protecting ammunition or explosives, structures, or operations against high-velocity, low-angle fragments although the barricades may be destroyed in the process. Since such fragments move along ballistic trajectories rather than straight lines, reasonable margins in barricade height and length must be provided beyond the minimum dimensions that block lines of sight. Barricades also provide limited protection against blast in the immediate vicinity. They do not protect against high-angle fragments and are ineffective in reducing the blast pressure in the far field (IBD or PTRD).

*b. Barricade requirements.* Underground storage facilities present special conditions that must be accounted for in portal barricade design. Specific criteria for location and construction of portal barricades are provided in paragraph 16–25e, below. For other than underground facilities, protection is considered effective when barricades meet the following minimum requirements:

(1) The slope of a barricade may not be steeper than 1.5 horizontal to 1 vertical in order to meet explosives safety requirements. Facilities constructed in the future should have a slope of 2 horizontal to 1 vertical to reduce erosion and facilitate maintenance operations.

(2) Determine the height and length of barricades as follows:

*(a) Height.* Establish a reference point at the top of the far edge of one of the two stacks under consideration between which the barricade is to be constructed. This reference point, if the top of the stacks are not at the same elevation, will be on the stack whose top is at the lower elevation. Draw a line from the reference point to the highest point of the other stack. Draw a second line from the reference point forming an angle of 2 degrees above the line.

*(b)* To preclude building excessively high barricades, the barricade should be located as close as possible to the stack on which the reference point was established. When the stacks are of equal height, the reference point may be established on either stack. (See fig 16–1.)



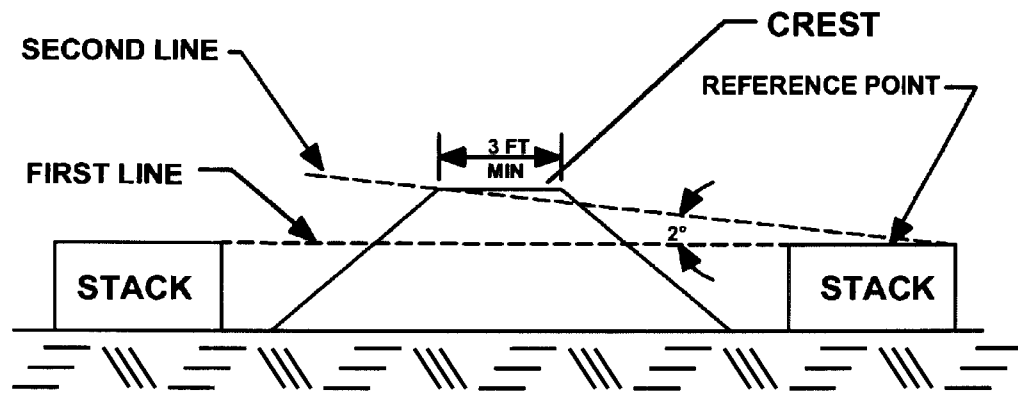

A. Level Terrain

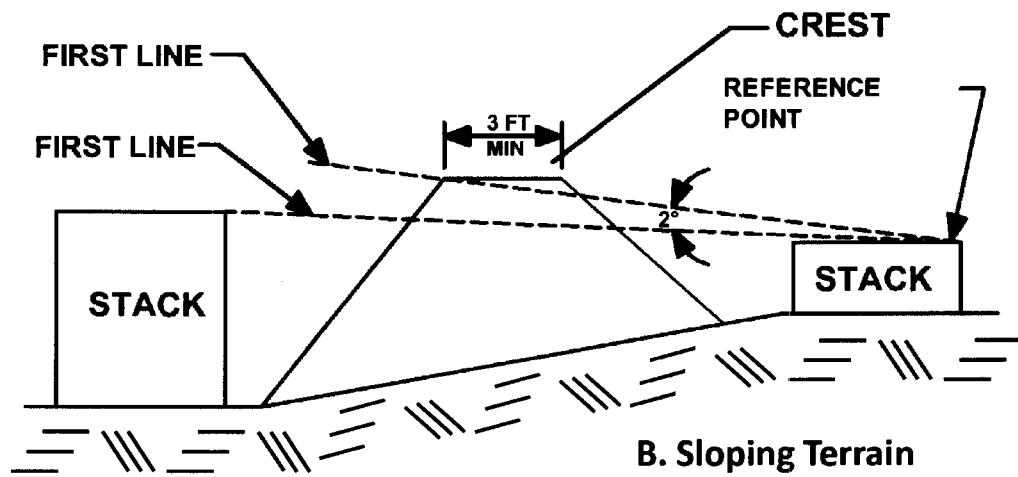

B. Sloping Terrain

Figure 16-1. Determination of barricade height

(3) Length. The length of the barricade will be determined as shown in figure 16-2.

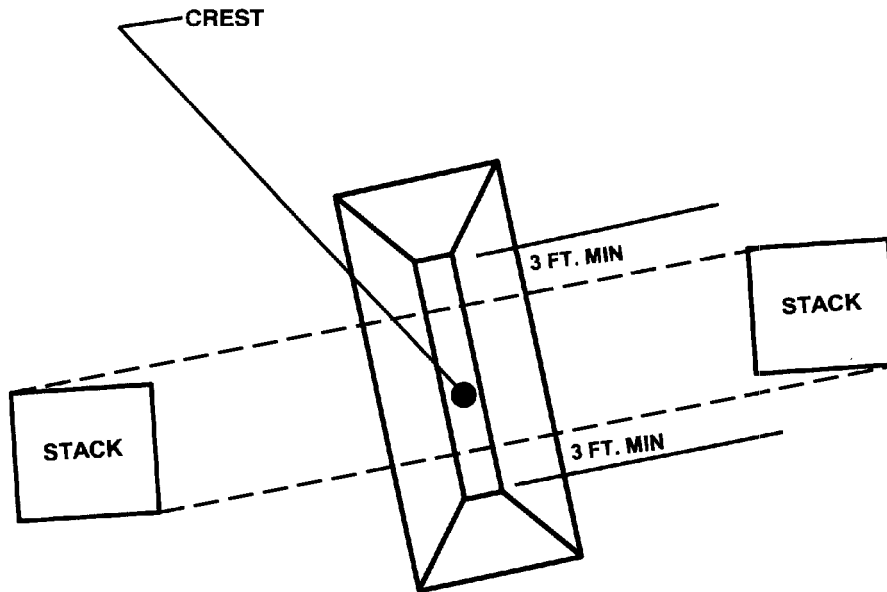

Figure 16-2. Determination of barricade length

(4) Earth barricades that meet the above requirements may be modified by substituting a retaining wall, preferably of concrete, for the slope on one side. The remaining side will be of such slope and thickness as necessary to ensure that the width of earth required for the top is held firmly in place.

(5) Other intervening barriers meeting the above requirements or proven effective by test also may be used; for example, earth-filled steel bin barricades for explosives-loaded aircraft.

*c. Location of barricades.*

(1) The distance between the foot of the barricade and the stack of ammunition or explosives or buildings containing explosives is necessarily a compromise. The smaller the distance, the less the height and length of the barricade required to secure proper geometry for intercepting projections. On the other hand, it may be essential to make the distance great enough to provide access for maintenance and vehicles.

(2) If it is impractical to locate the barricades as described in (1), above, they may be located adjacent to the facility to be protected. (See fig 16-3.)

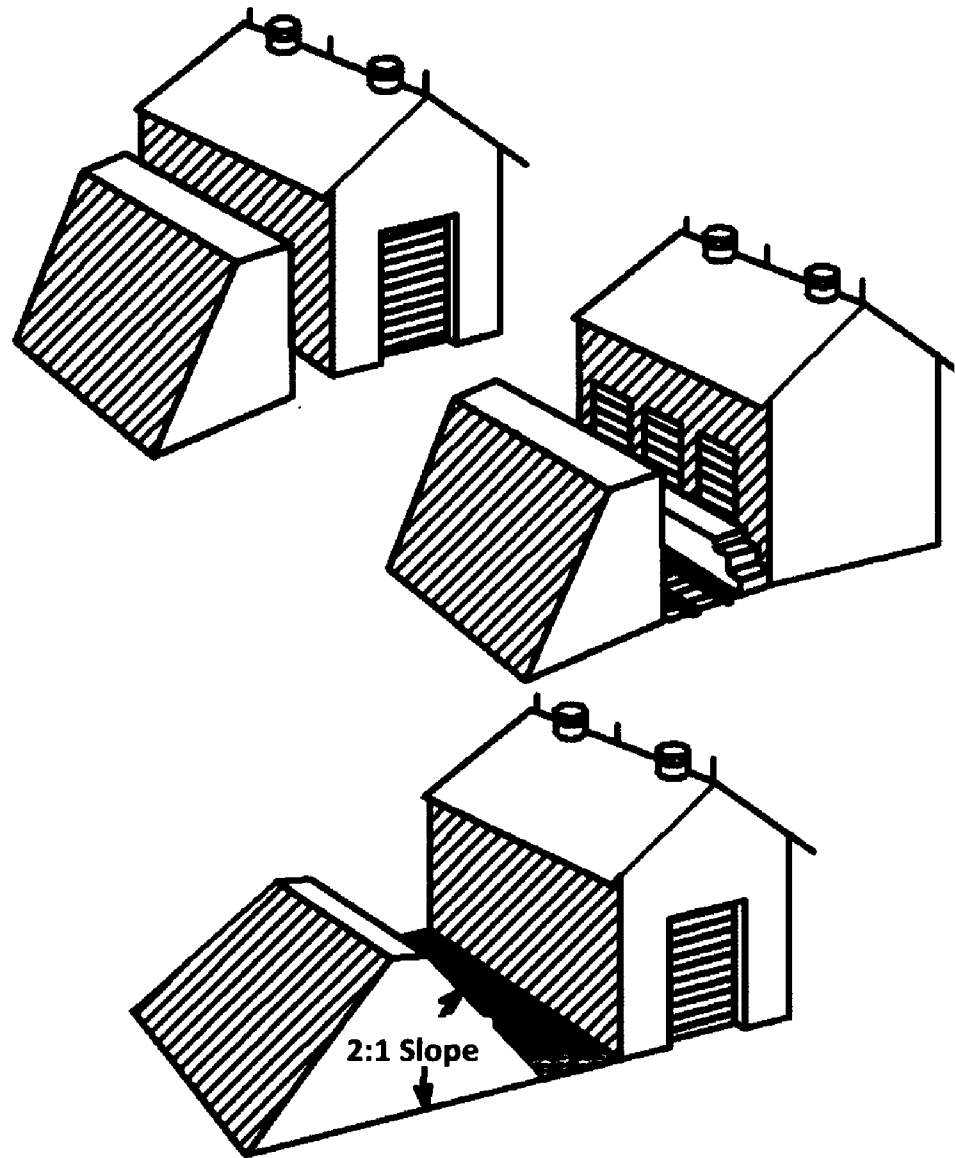

Figure 16–3. Barricade locations

*d. Earth cover for magazines and barricades.*

(1) Material for earth-cover over magazines and for barricades will be reasonably cohesive (solid or wet clay or similar types of soil may not be used as they are too cohesive). They are to be free from deleterious organic matter, trash, debris, and stones heavier than 10 pounds or larger than 6 inches in diameter. The larger stones will be limited to the lower center of fills and will not be used for earth cover over magazines. Compaction and surface preparation will be provided, as necessary, to maintain structural integrity and avoid erosion. When it is impossible to use a cohesive material, for example, in sandy soil, the barricade or the earth cover over magazines will be finished with a suitable material to ensure structural integrity.

(2) The earth-fill or earth-cover between earth-covered magazines may be either solid or sloped to meet the requirements of other construction features. However, a minimum of 2 feet of earth must be maintained over the top of each magazine. See paragraph 8–10 for QD requirements for magazines with less than 2 feet of earth cover. A

minimum slope of 1.5 horizontal to 1 vertical starting directly above the spring line of each arch will be maintained to meet explosives safety requirements. Facilities constructed in the future will have a slope of 2 horizontal to 1 vertical to reduce erosion and ease maintenance operations.

*e. Portal barricades for underground magazines.*

(1) Portal barricades for underground magazines are located immediately in front of an outside entrance or exit (i.e., the portal) to a tunnel leading to an explosives storage point. The portal barricade should be centered on the extended axis of the tunnel that passes through the portal. Specific design criteria for a portal barricade are given in the Corps of Engineers definitive drawing number DEF 421-80-04.

(2) Portal barricades for underground magazines [CCA] must be located a distance of not less than one and not more than three tunnel widths from the portal. The actual distance should be no greater than that required to allow passage of any vehicles or materials handling equipment that may need to enter the tunnel.

(3) To withstand the impact of debris ejected from the tunnel, the front face of the portal barricade (including wing-walls) must be constructed as a wall of reinforced concrete, with a minimum thickness equal to 10 percent of the barricade height, but in no case less than 12 inches. The concrete wall must have a spread footing of sufficient width to prevent significant settlement, and the central wall, wing-walls, and footing must be structurally tied together to provide stability. The backfill behind the concrete wall may be composed of any fill material, including rock rubble from the tunnel excavation, with a maximum particle size of six inches within the area extending out to three feet from the rear face of the wall.

*f. Earth-filled, steel bin-type barricades (ARMCO revetments or equivalent) for outside storage.*

(1) These barricades, also known as ARMCO revetments, are earth-filled steel bins used to separate munitions awaiting scheduled processing, such as, munitions on flight lines associated with aircraft parking/loading operations or the temporary positioning of munitions awaiting transfer to preferred long-term storage. The barricades are also used to separate uploaded aircraft. These barricades are normally used to form a series of cells. The barricades are designed to limit the MCE (for QD siting purposes) of the munitions stored in separate cells by preventing prompt detonation transfer to adjacent cells provided the munitions in each cell of the facility are properly positioned.

(2) The ARMCO Inc. revetment cells are approved for storage of any HD 1.1 and HD 1.2 AE assigned to sensitivity groups 1 through 4 and the storage of HD 1.3, HD 1.4, and HD 1.6 items. An explanation of sensitivity groups are provided in table 16-1.

(3) The ARMCO revetments as sited below should only be considered for preventing prompt detonation transfer, and that all munitions (and aircraft) in the series of cells are at risk of loss. In other words, although the revetments are effective in limiting the blast loading of unrelated Exposed Sites to that produced by the largest contents of a single cell, there is a significant probability that the contents of many cells will be damaged or destroyed by the initial and subsequent fire and explosion events. The extent of such losses increases with the amount of explosives present. Therefore, if valuable munitions and/or aircraft assets are to be preserved, then the quantities allowed in cells should be limited to satisfy valid essential operational requirements.

(4) There are two type of ARMCO revetments, Type A and Type B. Type A revetments must be a minimum of 7 feet thick. Type B revetments must be a minimum of 5.25 feet thick. Type A ARMCO revetments may be used to limit the MCE in a series of cells to the largest quantity in a cell if that quantity does not exceed 30,000 pounds NEW. Type B ARMCO revetments may be similarly used to limit the MCE provided no cell contains more than 5,000 pounds NEW. The following conditions must be met:

(a) In addition to satisfying the criteria illustrated in figures 16-1 and 16-2, munitions must be positioned no closer than ten feet from cell walls, no closer than three feet from the end of the wing-walls, and no higher than two feet below the top of cell walls.

(b) Munitions shall be positioned with the objective of distributing them over the available area within the cell, rather than concentrating them in a small area. The contents of a cell (stored in quantities near the maximum NEW limit) must not be configured into a single row of pallets, stacks or trailers.

(c) Storage of munitions in inflammable outer-pack configurations must be minimized.

## **16-26. Policy on protective construction**

Advances in protective construction allow a calculated degree of protection from explosion communication between adjacent bays or buildings. They also protect personnel in adjacent bays or buildings against death or serious injury from incidents, and protect vital and expensive equipment installations. Therefore, the major objectives in facility planning will be as follows:

a. Protection against explosion propagation between adjacent bays or buildings and protection of personnel against death or serious injury from incidents in adjacent bays or buildings (chap 8).

b. If personnel and facilities would be better protected or costs reduced significantly by having separate buildings to limit explosion propagation rather than using protective construction and separation of explosive units within one building, planning will reflect this fact.

c. Protection for vital and expensive equipment if the additional cost is warranted.

## 16–27. Strengthening (hardening of buildings)

When sufficient protection can be provided either by hardening a target building or by constructing a source building to suppress explosion effects, these factors may be taken into account, and the distance required by the standard QD tables may be reduced. Site and general construction plans for ammunition and explosives facilities that propose reduced distances based upon protective construction will be accompanied by the rationale or test results. These must justify the reduction when they are submitted for DDESB approval.

## 16–28. Substantial dividing walls

*a. Definition.* A substantial dividing wall (SDW) is a reinforced concrete wall having the following characteristics:

- (1) Minimum thickness of 12 inches.
- (2) Steel reinforcing bars (rebar) on both faces of the wall.
- (3) Minimum steel reinforcing bar size #4 (1/2-inch in diameter).
- (4) Vertical and horizontal rebar spaced not more than 12 inches on center apart.
- (5) Position of bars on one face staggered with the bars on the opposite face.
- (6) Two inches of concrete cover over the reinforcing bars.
- (7) Minimum concrete compressive strength of 2,500 pounds per square inch (psi).

*Note.* The main steel must be continuous into supports. The 12-inch SDW must be supported at the floor and at any adjacent 12-inch SDWs.

*b. Applicability.* This guidance applies to 12-inch thick SDW with the explosives located at least three feet from the SDW between the bays. When used as a firewall for HD 1.3 ammunition and explosives (AE), the 12-inch thick SDW must be continuous from the floor to the roofline to mitigate thermal effects unless otherwise required by local fire codes to extend above the roof. When used for personnel protection, the 12-inch thick SDW must be adequately supported on at least two sides.

*Note.* Existing 12-inch thick reinforced concrete walls constructed for explosives operations, explosives storage, or remotely controlled explosives operations at DOD facilities are considered adequate for this application.

*c. Use.*

(1) To prevent simultaneous detonation for HE and propagation of reaction (burning) for HD 1.3 between adjacent bays:

(a) Each bay containing HE (to include any HD 1.3 contributions) shall be limited to a MCE of no more than 425 pounds explosive weight of Sensitivity Groups (SG) 1, 2, 3 and/or 4 munitions (SG's are defined in table 16–1). (Note: See the JHCS and table 16–1 for additional information) Test data does not currently support the use of a 12-inch thick SDW to prevent the simultaneous detonation of SG 5 munitions. Therefore, when establishing the MCE, the explosive weight of all munitions in a bay that contains any SG 5 munitions must be combined with the MCE for any adjacent bays that contain either greater than 8 pounds of HD 1.1 or greater than 300 pounds of HD 1.3. HD 1.4 AE does not contribute to the MCE.

Sensitivity Group		Compatibility Group (CG)	Ordnance Description	Critical Acceptor Ordnance
#	Description			
1	Robust	C, D, E	Bombs, Projectiles, Thick-Case Munitions	MK82, MK83, MK84 Bombs M107-155mm Projectile WALLEYE <sup>1</sup>
		J	Ammunition with both Explosives & Flammable Liquids	HARPOON TOMAHAWK
2	Non-Robust	D, E	Thin-Case Items: Most Missiles, Rockets, Underwater Mines & Torpedoes	MK103/MK10 Torpedo Warheads MK55 Underwater Mine
3	Fragmenting	D, E	Fragmenting Missile Warheads	WAU17 Sparrow Warhead
4	Cluster Bombs/Dispenser Munitions	D, E	Cluster Bombs, Dispenser Munitions	M483 Bomblet M864 Bomblet
		J	Ammunition with both Explosives & Flammable Liquids	TOMAHAWK
5	SD Sensitive	B	Detonators and Initiating Devices	#8 Blasting Cap
		F, G	Fireworks, Incendiary, Illuminating, Smoke or Tear Producing Munitions; Ammunition with Initiation Devices	M106 Grenade M61 Grenade
		C, D, E	Demolition Explosives, Very Thin-case items; Sheet Explosives, Sensitive Non-Robust	M118 PETN & MK36 H6 Demo Blocks TOWII / HELLFIRE <sup>1</sup>

Note:

1. Directed Energy Weapon. Stowage plan must orient directed energy jet away from non-propagation wall (NPW).

Figure 16-4. Sensitivity groups

(b) Bays containing only packaged HD 1.3 AE should be limited to an explosive weight of no more than 5,000 pounds and bays containing unpackaged HD 1.3 AE should be limited to an explosive weight of no more than 300 pounds; otherwise, the explosive weights of those bays must be combined with the MCEs for all adjacent bays. Those bays containing only HD 1.3 AE must have adequate venting area; that is, a frangible wall or roof.

(2) To provide personnel protection for remotely controlled operations:

(a) Operations involving HE (to include any HD 1.3 contributions) shall be separated either by the shorter K24 separation distance when measured over or around the 12-inch thick SDW or by the shortest distance that provides 2.3 psi level of protection to personnel.

(b) Operations involving only HD 1.3 AE, where mass fire is assessed to be the response during an accident, shall be separated by the shorter K8 separation distance when measured over or around the SDW or by the shortest distance that limits the thermal flux to personnel to 0.3 calories/cm<sup>2</sup>/sec. Guidance in paragraph 16–28c(2)(a) above applies when the expected response during an accident is an explosion or detonation.

(c) Personnel shall be protected from fragments and debris having energies of 58-foot-pounds or greater (hazardous fragments). A 12-inch thick SDW that is properly supported on two sides (such as a reinforced concrete floor and another 12-inch thick SDW) defeats and does not generate hazardous fragments for an MCE of up to 300 pounds of HD 1.3 AE or for up to 8 pounds of HE (to include any HD 1.3 contribution) of SG 1, 2, 3, 4 and/or 5 in the operating bay. HD 1.4 AE does not contribute to the MCE.

d. These walls are one way of separating explosives into smaller groups to minimize the results of an explosion and allow a reduction in QD separation. See chapter 8 for criteria for the levels of protection offered by these walls based upon the quantity of explosives present and the design characteristics of the wall.

e. Blast doors which separate explosives working spaces or storage spaces in existing buildings will meet design-definitive drawing specifications. Such doors should be at least as strong as adjacent walls (see TM 5–1300 for design factors for new structures). These doors are not to be installed as a matter of convenience. Blast doors should be avoided when a continuous reinforced wall would not interfere unnecessarily with operations.

## **Chapter 17**

### **Electrical Hazards and Protection**

#### **Section I**

##### **Electrical Service and Equipment**

##### **17–1. Overview**

The installation and use of electrical equipment within buildings, magazines, operating locations, shelters, and so forth, containing explosives will comply with the latest edition of the NFPA, Standard 70, or applicable portion of IEC 62305 unless stated otherwise in this chapter.

##### **17–2. Hazardous locations**

Locations are classified depending on the properties of the flammable vapors, liquids or gases, or combustible dusts or fibers which may be present and the likelihood that a flammable or combustible concentration or quantity is present. Where pyrophoric (spontaneously igniting in air) materials are used or handled, these locations will not be classified. Each room, section, or area will be considered individually in determining its classification. To qualify as a hazardous location, conditions listed in paragraph 17–2 a through c should either exist or be probable in the location. Hazardous locations are divided into three classes. Each class consists of two divisions: Division 1 (more hazardous) and division 2. Hazardous locations require either explosives-dusts, flammable vapors, or ignitable flyings (or fibers) to be present in a proper mixture with air. Ammunition storage structures will not normally have the proper mixture and would not be considered a hazardous location within the context of this definition. Additional information can be found in NFPA 70, article 500.

a. *Class I.* Class I locations are those in which flammable gases or vapors are or may be present in the air in quantities sufficient to produce explosive or ignitable mixtures. Rooms or buildings containing vapors from explosives which may condense will be considered Class I, Division 1 locations. Electrical equipment must have been tested and listed by a recognized testing agency as suitable for installation and use in Class I hazardous locations for safety of operation in the presence of flammable mixtures of specific vapors or gases in the air.

(1) *Class I, Division 1.* Class I, Division 1 locations are those in which—

(a) Hazardous concentrations of flammable gases or vapors exist continuously, intermittently, or periodically under normal operating conditions.

- (b) Hazardous concentrations of flammable gases or vapors may exist frequently because of repair or maintenance operations or because of leakage.
- (c) Breakdown or faulty operation of equipment or processes which might release hazardous concentrations of flammable gases or vapors might also cause simultaneous failure of electrical equipment.
- (d) Explosives may sublime and outgas.
- (e) Equipment operating temperatures will not have an external temperature capable of igniting the flammable mixture of the specific gas or vapor in its location.
- (2) *Class I, Division 2.* Class I, Division 2 locations are those in which—
- (a) Volatile flammable liquids or flammable gases are handled, processed, or used. In these areas the hazardous liquids, vapors, or gases normally are confined within closed containers or systems from which they can escape only in an accidental rupture or breakdown of such containers or systems or during abnormal operation of equipment.
- (b) Positive mechanical ventilation normally prevents hazardous concentrations of gases or vapors from accumulating, but concentrations might become hazardous if the ventilating equipment fails or malfunctions.
- (c) Hazardous concentrations of gases or vapors occasionally might accumulate if they spread from adjacent Class I, Division 1 locations unless prevented by adequate positive-pressure ventilation from a source of clean air, and effective safeguards against ventilation failure are provided.
- b. *Class II.* Class II locations are those locations which are hazardous because of the presence of combustible dust. Rooms or buildings that contain explosive dusts or explosives having a chemical composition or physical size such that particles of explosives may become disassociated from the whole and disperse in the surrounding atmosphere will be considered Class II hazardous locations. Equipment installed in Class II locations will be able to function at full rating without developing surface temperatures high enough to cause excessive dehydration or gradual carbonization of any organic dust deposits that may be present. Dust that is carbonized or excessively dry is highly susceptible to spontaneous ignition. Operating temperatures of electrical equipment will not be high enough to ignite expected dusts in its location if equipment, such as motors, power transformers, and so forth, becomes overloaded. Equipment and wiring that meets all the requirements of NFPA 70, Article 500 for Class II locations is required. Equipment and wiring defined as explosion proof may not meet all those requirements.
- (1) *Class II, Division 1.* Class II, Division 1 locations are those in which—
- (a) Combustible dust is or may be suspended in the air continuously, intermittently, or periodically under normal operating conditions in quantities sufficient to produce an explosion or ignition.
- (b) Mechanical failure or malfunctioning machinery or equipment may cause explosive or ignitable mixtures to be produced, or become a source of ignition through simultaneous failure of electrical equipment and protection devices or other causes.
- (c) Combustible dusts which are electrically conductive may be present.
- (d) Explosives or explosive dusts may, during handling, produce dust capable of being dispersed in the atmosphere.
- (e) Explosives may outgas.
- (2) *Class II, Division 2.* Class II, Division 2 locations are those in which—
- (a) Combustible dust will not normally be suspended in the air, or thrown into suspension, by the normal operation of equipment or apparatus in quantities sufficient to produce explosive or ignitable mixtures.
- (b) Deposits or accumulations of dust may be sufficient to interfere with the safe dissipation of heat from electrical equipment or apparatus.
- (c) Deposits or accumulations of combustible dust on, in, or in the vicinity of, electrical equipment may be ignited by arcs, sparks, or burning material from electrical equipment.
- c. *Class III.* Class III locations are those that could be hazardous because of the presence of easily ignitable fibers or flyings, but where these fibers or flyings are not likely to be in suspension in the air in quantities sufficient to produce ignitable mixtures. These locations include combustible fiber manufacturing pressing plants, woodworking plants, and establishments involving similar hazardous processes or conditions. Easily ignitable fibers and flyings include rayon, cotton, hemp, oakum, excelsior, and other materials of similar nature.
- (1) *Class III, Division 1.* Class III, Division 1 locations are those in which easily ignitable fibers or materials that produce combustible flyings are handled, manufactured, or used.
- (2) *Class III, Division 2.* Class III, Division 2 locations are those in which easily ignitable fibers are stored or handled, excluding locations where ignitable fibers are stored or handled during manufacturing.
- d. *Change of classification.* Operating buildings and magazines are constructed to perform a specific function which dictates the requirements for electrical equipment installation. If the functions performed in the facility change or are rearranged, the safety officers must inspect, approve, or reclassify the hazardous locations. Multiple classifications are discussed in the following paragraph.
- e. *Multiple classifications.* In some areas of Army operating buildings or magazines there may be risks from both dust and flammable vapors. If so, these areas will have a dual or multiple classifications. Electrical equipment used in these areas must be listed by a recognized testing agency as suitable for use in all hazardous locations to which it will be subjected.



*f. Special requirements.*

(1) To maintain maximum long-term flexibility of use for facilities, electrical equipment and installations in Class I, II, or III hazardous locations involving explosives should comply with the requirements of the code for Division 1 of the appropriate hazardous location class. Equipment and installations in locations that could be used as either a Class I or II hazardous location will meet the requirements of both classes.

(2) An alternate source of power must be available for explosives operations where the lack of a continuous power supply may cause a fire or explosion.

(3) Low power, solid state devices which are intrinsically safe under the NFPA, Standard 70, Article 504, may be used in any hazardous location, provided they do not introduce a physical or electromagnetic radiation (EMR) hazard. See section III of this chapter for more information on EMR.

*g. Maintenance.* More than ordinary care will be taken to maintain equipment and electrical installations in hazardous locations. The equipment must be periodically inspected and maintained by qualified personnel, with a written record kept of the inspections and maintenance. Where inspection frequency is not prescribed in a TM or other directive, the inspection period will be fixed by local authority on the basis of the existing situation.

*h. Photographic lighting.* Electronic flash photography equipment may be used in ammunition/explosives areas after completion of an assessment of the risks involved. Use of flash photography equipment in hazardous dust or vapor environments (concentrations of dust or vapors in the flammable/explosives range) is prohibited.

*Note.* Use of flash photography in the vicinity of active UV sensors for ultra high speed deluge systems will result in activation of the system.

### **17-3. Approved equipment**

*a. Listed equipment.* Electrical equipment listed by a recognized testing agency, is acceptable only when used under the recommended environmental and operational conditions. Equipment will be approved not only for the class of location but also for the explosive properties of the specific gas, vapor, or dust that will be present. For additional details, see NFPA 70.

*b. Unlisted equipment.* Electrical equipment not specifically listed by a recognized testing agency for the purpose or operating condition present may be certified for use by a qualified safety or system safety engineer (GS-803). This certification will be based on the following:

(1) Listed equipment is not available from any source.

(2) Hazard analysis has determined that no additional risks would be created by using this equipment. Unlisted equipment certification and justification thereof must be maintained at the installation until the equipment is withdrawn from service.

*c. Underground storage facilities.* All wiring and electrical equipment in underground storage facilities must, in addition to any other requirements of this chapter, be of moisture and corrosion resistant materials and construction unless a site-specific analysis indicates that such construction is not necessary. Underground facilities must have emergency lighting systems to provide minimum illumination in the event of a power failure.

### **17-4. Maintenance of electrical equipment**

Only qualified personnel authorized to do such work will perform maintenance. Where equipment may have been contaminated by explosives, the explosives will be removed or neutralized before maintenance is started.

### **17-5. Electrical service lines in explosives areas**

Each service line will be run underground from a point at least 50 feet away from the building. The exterior line side of the main disconnecting switch or circuit breaker must have suitable lightning arrestors. See paragraph 8-9 and table 8-6 for separation distance for electrical lines.

*a.* Surge (lightning) arresters will be required and installed as specified in NFPA 70, Article 280.

*b.* Local telephone service and similar low voltage intercom or alarm systems must also comply with the same underground routing for the last 50 feet. Surge protection, even for lines that run underground, will be provided to shield against any severe electrical surges from a nearby lightning strike or from excessive power through the line from other outside sources, such as broken power lines. Surge suppression for incoming conductors must include suppression at the entrance to the building from each wire to ground.

*c.* Ground fault interrupters virtually eliminate electrical shock hazards presented by line-to-ground fault currents and leakage currents by removing power from the faulty circuit. When building or renovating facilities, all 120 volts alternating current (VAC) single-phase receptacle outlets installed outdoors will have ground fault circuit protection. Ground fault protection will be provided in other areas where conditions creating a high-level electrical hazard exist. Ground fault circuit interrupters can often be activated by spurious electrical impulses. Therefore, these devices will not be used on circuits that serve critical equipment and processes; for example, lighting in an explosives building, or lighting required for a safe exit from any building.

### **17-6. Electrical motors for hazardous locations**

Electrical motors should not be installed in a room or building which is a Class I or II hazardous location. They should have no connection to the building except through glands or apertures adequately sealed against entrance of hazardous materials either into the location or into the motor itself. If an electrical motor must be located in a hazardous location, paragraph 17-3 applies.

### **17-7. Portable lighting systems**

a. Floodlight systems, which are listed by a recognized testing agency, may be used where required. These will be mounted on heavy portable stands and placed outside the magazine door or the outside working area. Service cords must be placed or protected so that they cannot be walked on or run over by equipment. These lights must be rated for the environment which is present, that is, if explosives dusts or vapors are present, the lights must be rated for that environment or must be placed outside the structure or outside the area where the dust/vapor hazard is present.

b. Flashlights and hand lanterns powered by low voltage dry cell batteries and miners' cap lamps, each approved as permissible by the U.S. Bureau of Mines and by a recognized testing agency for Class I hazardous locations, are considered satisfactory for both Class I and II hazardous locations. In Class III hazardous locations and nonhazardous explosives locations, any type dry cell flashlight is acceptable. Devices which provide cold light through chemical action are acceptable for any hazardous location.

### **17-8. Permanent lighting for storage magazines**

If permanent lighting is essential, an approved type of disconnect switch must be used. The switch will be placed outside the magazine and arranged so that it can be locked in the open position. The power will be on only when personnel are working in the magazine. The magazine doors will be opened and the magazine interior will be visually inspected before actuating the switch. As a minimum, spark-proof, or industrial rated electrical systems in rigid metal conduits, enclosed junction boxes, and closure plates without opening and protective covers for lighting fixtures will be used. Explosion proof lighting is required only for the hazardous locations listed in paragraph 17-2.

### **17-9. Flexible cords**

Flexible cords should be type "S" hard service cords approved for extra hard usage in damp areas as defined in the NEC. Splices are not allowed. All flexible cords with plugs must be equipped with a ground. Flexible cords will not be used in place of fixed or installed electrical wiring. Place or protect each electrical cord so that it cannot be walked on or run over by equipment.

## **Section II**

### **Static electricity**

#### **17-10. Static electricity charge dissipation subsystem**

##### *a. General information.*

(1) *Static electricity.* Static electricity is produced when two unlike materials are brought into contact and then separated. During contact, there is a redistribution of the charge across the area of contact and an attractive force is established. When the materials are separated, work is done in overcoming these attractive forces. This work is stored as an electrostatic field which is set up between the two surfaces when they are separated. If no conducting path is available to allow the charges to bleed off the surfaces, the voltage between the surfaces can easily reach several thousand volts as they are separated. Static electricity is an annoyance to many individuals. Static shock may cause discomfort and even injury to a worker due to involuntary reaction. A far more dangerous aspect of static electricity is the fire and explosion hazard. This hazard can occur in situations where a vapor-air, gas-air, dust-air, or combination of these mixtures exists in the proper ratio. For static to cause ignition, four conditions must exist:

- (a) An effective means of static generation.
- (b) A means of accumulating the charges and maintaining a difference of electrical potential.
- (c) A spark discharge of adequate energy.
- (d) The spark must occur in an ignitable mixture.

(2) *Sources.* The most common sources of static electricity are—

(a) Steam, air, or gas flowing from any opening in a pipe or hose, particularly when the stream is wet or when the air or gas stream contains particulate matter.

(b) Pulverized materials passing through chutes and pneumatic conveyors.

(c) Non-conductive power or conveyor belts in motion.

(d) Moving vehicles.

(e) All motion involving changes in relative position of contacting surfaces (usually of dissimilar substances), of which one or both must be a poor conductor of electricity. The following paragraph provides information and procedures on how to control static electricity charge dissipation.

(3) *Materials sensitive to static spark discharge.* Practically all finely divided combustible materials, especially

explosives, when suspended in the proper concentration in air or deposited in finely divided layers, can be ignited by an electrostatic spark.

(a) *Explosives.* The explosives or explosive mixtures that are sensitive to static discharge (electrostatic sensitivity of 0.1 joule or less) when exposed are generally primer, initiator, detonator, igniter, tracer, incendiary, and pyrotechnic mixtures. Ammonium picrate, tetryl, RDX compositions, and tetrytol are sensitive to static discharge when present in dust-air mixtures. The following are some of the explosives that can be ignited by a static electricity spark discharged from a person: black powder; diazodinitrophenol (DDNP); igniter compositions; lead azide; lead styphnate; aluminum, magnesium, titanium, uranium, or zirconium powder exposed in layers; mercury fulminate; mixtures of flammable vapors; potassium chlorate mixed with flammable dusts; pyrotechnic mixtures; smokeless powder dust when present; and tetrazene.

(b) *Electro-explosive devices.* Static electricity on insulated conductive objects, such as metal stands with rubber casters, or on a person, can discharge through the air to other objects which are at a sufficiently different potential. Such a discharge or spark, even though too small to be felt, may contain enough energy to cause an electro-explosive device, such as a primer or a detonator, to fire. Static discharges may also be strong enough to break down the insulation within the electro-explosive device and cause it to fire.

(c) *Solvents.* Flammable mixtures of solvents and air can be ignited by the static charge that can be accumulated on a person. Typical flammable solvents are ethyl ether, ethyl alcohol, ethyl acetate, acetone, benzene, and naphtha.

(4) *Static generating materials.* Personnel who work in a hazardous location or who handle or install unpackaged electro-explosive devices and ammunition must avoid using rags and wearing outer garments made of materials which have high static generating characteristics. Materials of 100 percent polyester, nylon, rayon, silk, or wool are highly static-producing. Wool socks, glove inserts, and caps, as well as undergarments of synthetic fabrics or silk are less of a hazard. Nylon field jacket liners should not be worn as an outer garment. Cotton or cotton-synthetic blend materials are preferred.

(5) *Static electrical potential discharge or equalization.* Personnel, regardless of the type of clothing worn, can collect a charge of static electricity by being in contact with moving non-conductive substances or coming in contact with a mass that has been previously charged. Therefore, personnel must be particularly careful to discharge their static electrical potential or equalize it to that of the explosives item before the item is handled.

(6) *Garment removal.* Garments will not be put on or removed while engaged in explosives operations. This reduces the generation of static charges caused by physical separation of materials. If outer garments need to be removed, personnel will step out of the immediate area of operation, remove the garment, ground themselves, and then reenter. Workers shall not unfasten Velcro fasteners while present in an explosives operation.

*b. Static electricity dissipation.*

(1) The grounding method generally used to eliminate or reduce the hazard from static electricity is to provide an electrically continuous path to the earth electrode subsystem.

(a) When all of the objects are conductive, they can be grounded by electrically connecting all parts to a common ground conductor.

(b) When necessary, effective grounding must include the exterior and the contents of a container.

(c) Electrical continuity may be broken by oil on bearings, paint, or rust at any contact point. To get a continuous circuit, grounding straps should be used to bridge such locations. Equipment in contact with conductive floors or table tops is not adequately grounded.

(d) Static grounds will not be made to telephone grounds; electrical conduit systems; gas, steam, water, or air lines; sprinkler systems; or air terminals of lightning protection system (LPS) (connection to the down conductor of the system at the ground level is authorized).

(2) Static electricity accumulations and subsequent discharges are usually impossible if the relative humidity is above 60 percent. Where humidification techniques are used to prevent static electricity accumulations, perform a daily preoperational check of the humidity levels before starting work. However, certain materials such as metallic powders and some of the pyrotechnic mixtures cannot be exposed to air with 60 percent or higher relative humidity because of the possibility of spontaneous ignition.

(3) Ionization is electrical neutralization and serves as an effective method of removing static charges from certain processes and/or operation. Methods of application can be found in NFPA Recommended Practice 77. Ionization methods of removing static charges must not be used in hazardous locations as defined in the National Electrical Code, NFPA 70, and paragraph 17-2 of this pamphlet. Unless the ACOM, ASCC, or DRU commander gives approval, do not use radioactive ionization sources due to the potential for radioactive material contamination during an explosives accident or pyrotechnic fire.

*c. Conductive floors, mats, and runners.* The combination of conductive floors and shoes provides the static electricity charge a dissipation path to the earth electrode subsystem.

(1) General requirements.

(a) Conductive floors, plates, mats, and runners will be used together with conductive footwear to protect personnel at operations involving items and materials having an electrostatic sensitivity of 0.1 joule or less. A list of items and materials that are sensitive to this level are listed in paragraph 17-10a (3)(a) through 17-10a(3)(c). Operations

involving such items as loosely unpacked ammunition with electric primers, exposed electro-explosives devices, electrically initiated items with exposed electric circuitry, and other hazardous materials will be analyzed on a case-by-case basis to determine if conductive floors, plates, mats, runners, and footwear are required. This analysis will include an assessment of the electrostatic sensitivity of the item and the compensatory measures to be employed.

(b) Conductive floors are not required throughout a building or room if the hazard is localized. In these cases, conductive mats or runners may be used where appropriate. These mats or runners will be subject to all the specifications and tests that apply to conductive floors.

(2) New installation or renovation requirements. Conductive floors must be constructed of non-sparking material such as lead, conductive rubber, or conductive flooring composition and must meet the following requirements:

(a) The surface of the installed floor must be free from cracks and reasonably smooth. The surface material must not slough off, wrinkle, or buckle under operating conditions. Conductive tiles are not recommended in areas where explosives dust can cause contamination. The large number of joints and the tendency of tiles to loosen can allow explosives dust to become lodged. The tiles are not easy to clean using normal cleanup procedures.

(b) The conductive floors must be compatible with the materials to be processed.

(3) Conductive floor bonding requirements.

(a) Conductive floors will be bonded to the earth electrode subsystem. The bonding material will be selected in accordance with NFPA 70, Article 250, Part J, paragraphs 250-91 through 250-99, inclusively.

(b) On former Naval installations conductive floors will be bonded to the secondary girdle. The bonding material will be selected in accordance with NFPA 70, Article 250, Part J, paragraphs 250-91 through 250-99, inclusively.

(4) Visual inspection requirements.

(a) Visual inspection interval. Conductive floors will be inspected daily during operations.

(b) Visual inspection procedures. (See para C-2 and table 17-1 for inspection procedures.)

(5) Electrical test requirements.

(a) Electrical test intervals. Conductive floors will be tested at the completion of installation, at the completion of renovation, and at least semiannually thereafter.

(b) Electrical test procedures. Electrical tests will be conducted only when the room or area is free of exposed explosives and/or flammable gas mixtures. (See para C-3 and table 17-1 for testing procedures.)

(6) Maintenance of conductive floors. Conductive floors will be kept clean, dry, and free of non-conductive material. Soaps, detergents, and solvents that leave a residue will not be used to clean conductive floors.

*d. Conductive footwear.*

(1) *General requirements.* Personnel who work upon conductive flooring, conductive mats, or conductive runners where the requirements in paragraph c(1)(a) above apply, must wear non-sparking conductive footwear. Personnel from other departments or visitors who enter these areas and who walk on conductive flooring materials also must wear non-sparking conductive footwear (conductive overshoes with ankle straps may be used). Legstats are acceptable for visitors or transients only, as long as their basic footwear is of non-sparking construction. Under no circumstances will personnel working on electrical equipment or facilities wear conductive-sole safety shoes or other conductive footwear.

(2) *Conductive footwear requirements.*

(a) Conductive shoes with conductive composition soles will meet American Society for Testing Material (ASTM) F2413-05, Standard Specification for Performance Requirements for Foot Protection.

(b) Conductive footwear requires care to retain its conductive properties. When conductive footwear is not in use, it should be stored in lockers close to the room where it will be worn. Employees who have been issued conductive footwear will not wear it from the workplace to their homes and return. A thin layer of dust or wax may insulate conductive footwear from the floor.

(c) Only conductive materials will be used to repair conductive soled shoes. Conductive shoes will be thoroughly cleaned before being repaired.

(d) Ensure operating procedures inform employees that foot powder will not be used and that socks made of silk, wool, or nylon will not be worn with conductive shoes. Foot powder insulates and retards the conductive ability of the shoes. Silk, wool, and nylon produce static electricity.

(3) *Visual inspection requirements.*

(a) *Inspection intervals.* Conductive footwear will be inspected every day before use.

(b) *Inspection procedures and criteria.* (See para C-2 and table 17-1.)

(4) *Electrical test requirements.*

(a) *Test intervals.* Conductive footwear will be tested at the time issued and daily before use.

(b) *Test procedures.* (See para C-4 and table 17-1.)

*e. Conductive tables and table tops.* The requirements for conductive floors will apply to conductive tables and table tops.

*f. Conductive belts.*

(1) *New installation, renovation, and general requirements.* Conductive conveyor belts shall have a resistance not to exceed 5 megohm (5 million ohms) as measured between two electrodes placed on the belt and between the conductive

conveyor belt and the ground. Conductive conveyor belting shall be tested at the time of installation and at least semiannually thereafter. In areas exposed to large variances in relative humidity, additional measurements shall be made during times of lowest relative humidity to check the adequacy of belt conductivity. The results of the tests shall be recorded and maintained.

(2) *Bonding requirements.*

(a) The belt must be electrically continuous.

(b) The combination of the belt tension and the weight on the belt provides the bonding of the belt to the pulleys and rollers.

(c) The static electricity charge dissipation from the belt to the pulley or roller will also dissipate through the bearings to the equipment. The equipment in turn must be bonded to the earth electrode subsystem. Static combs or sliding contacts may be used between pulleys and roller to the equipment housing. Bonding straps can be used on the equipment housing. Braided straps will be required on equipment that vibrates.

(d) On former naval installations this subsystem must be bonded to the secondary girdle.

(3) *Visual inspection requirements.*

(a) *Inspection intervals.* Conveyor belt and v-belt systems will be inspected at installation or renovation and daily before use thereafter.

(b) *Inspection procedures and criteria.* (See para C-2 and table 17-1.)

(4) *Electrical test requirements.*

(a) *Test intervals.* All conveyor belt systems will be tested at the time of installation or renovation and at least semiannually. Conductive v-belts will be tested at time of installation (see para C-6), but need not be tested after installation.

(b) *Test procedures.* (See para C-5 and table 17-1.)

(c) Conductive v-belts will be tested at time of installation, but need not be tested after installation.

(d) *Test procedures.* These procedures for conductive v-belts (see para C-6 and table 17-1.)

g. *Conductive legstats.*

(1) *General requirements.* Legstats will not be used in place of conductive shoes. Only transients will use legstats when they require conductive footwear. Legstats will be used in pairs (one on each leg) when they are required.

(2) *Visual inspection requirements.*

(a) *Inspection intervals.* Legstats will be inspected upon receipt and daily before use.

(b) *Inspection procedures and criteria.* (See para C-2d and table 17-1.)

(3) *Electrical testing requirements.*

(a) *Test intervals.* Legstats will be tested upon receipt and daily before use.

(b) *Test criteria.* (See para C-7 and table 17-1.)

h. *Conductive wriststats.*

(1) *General requirements.* As a general rule, wriststats should not serve as the primary method of dissipating electrostatic charges from the human body. Wriststats may be a supplemental method when operations require more than normal precautions against electrostatic discharge. Wriststats may be used as the primary method of electrostatic control when directed by Army publications.

(2) *Visual inspection requirements.*

(a) *Inspection intervals.* Wriststats will be inspected upon receipt and daily before use.

(b) *Inspection procedures and criteria.* (See para C-2d and table 17-1.)

(3) *Electrical testing requirements.*

(a) *Test intervals.* Wriststats will be tested upon receipt and daily before use.

(b) *Test criteria.* The resistance value will be provided in the publication that requires the use of wriststats. (See table 17-1 and C-8.)

i. *Forklift trucks.* Requirements, inspection, and test procedures are in TB 43-0142.

j. *Machinery and equipment.*

(1) *General requirements.* All machinery and equipment such as mixers for pyrotechnic, propellant, and explosive compositions, screening and sifting devices, assembly and disassembly machines, elevators, defuzing machines, presses, hoppers, and all associated equipment involved in loading or processing explosives or explosives materials will be bonded to the earth electrode subsystem.

(2) *Visual inspection requirements.*

(a) *Inspection intervals.* Machinery and equipment will be inspected upon receipt and daily before use.

(b) *Inspection procedures and criteria.* (See para C-2e and table 17-1.)

(3) *Electrical testing requirements.*

(a) *Test intervals.* Machinery and equipment will be tested upon receipt and as specified in table 17-1.

(b) *Test criteria.* The resistance value between the machinery and equipment and the earth electrode subsystem will be as specified in paragraph C-9 and table 17-1.

*k. Spray painting operations.* During paint spraying operations, static electricity dissipation will be accomplished as required in NFPA 33 and/or NFPA 77. Electrostatic paint systems will not be used or installed in explosives areas.

*l. Aircraft loading and unloading operations.* Aircraft, both rotary and fixed wing, will be grounded when loading or unloading ammunition or explosives. The resistance value between the aircraft and the earth electrode subsystem will be as specified in table 17-1. For sling loading ammunition and explosives, see FM 55-450-2.

*m. Ground grab bars.* Ground grab bars may be installed just outside the entrance doors to operating buildings or other buildings or structures where special hazards exist. A ground grab bar consists of a length of noncorroding conductive pipe fitted in brackets and connected to ground. All persons entering structures equipped with grab bars will momentarily grasp the bar to dissipate any possible accumulation of static electricity. To prevent accumulation of a static charge, conductive floors, tables, footwear, and so forth, must be used.

*n. Field expedient grounding.* There will be times when, due to operational necessity, items such as conductive footwear and/or flooring will not be available. Appendix E provides methods that may be used in these situations.

### **17-11. Ordnance grounds (static grounds)**

Ordnance grounds are used to ensure that electric currents do not flow between ordnance components when they come in contact or are assembled. These currents can be produced by common mode voltages induced in ground loops, electrostatic discharge of one component into another, and potential differences created in the facilities ground system due to direct lightning strikes or near misses.

*a.* Ordnance grounds are electrically separated from all other ground systems (and objects connected to them). At former Navy installations, ordnance grounds will be connected to the secondary ground girdle at a single point. Each ordnance ground subsystem will be connected to the secondary ground girdle at a single point.

*b.* Where they exist, ordnance grounds will be maintained.

### **17-12. Instrument grounds**

Instrument grounds are used to provide error-free operation of sensitive electronic instruments.

*a.* Instrument grounds are electrically separated from all other ground systems (and objects connected to them). At former Navy installations, instrument grounds will be connected to the secondary ground girdle at a single point.

*b.* Instrument grounds at those installations having them will be maintained.

## **Section III Grounding**

### **17-13. Explosives facility grounding**

*a.* Explosives facilities will be provided with a ground system to provide personnel, equipment, and facility protection. Personnel safety is provided by low impedance grounding and bonding for personnel, equipment, metallic objects, and piping so as to prevent voltages sufficient to cause a shock hazard or initiate explosives within the facility.

*b.* A facility ground system is composed of the earth electrode subsystem and one or more of the following subsystems:

- (1) Static electricity charge dissipation subsystem.
- (2) Ordnance ground subsystem.
- (3) Instrument ground subsystem.
- (4) Lightning protection subsystem.
- (5) Structural ground subsystem.
- (6) Fault protection subsystem.
- (7) Power service grounds subsystem.

*c.* The explosives facility grounding system at all Army installations will be visually inspected and electrically tested at the required intervals for values specified in table 17-1.

(1) General requirements are as follows:

*(a)* The garrison or installation safety officer, unless an alternate officer is specifically designated by the garrison or installation commander, will maintain the inspection and test reports and/or records for the last six inspection cycles (12 years for records on a 24 month interval cycle). These records shall be reviewed for trend analysis.

*(b)* Personnel responsible for maintenance, inspection and testing must be familiar with the fundamentals described in NFPA 780 and herein as they relate to explosives facilities to assure the requirements of this pamphlet are met.

(2) All required maintenance will be performed on all grounding systems.

(3) Results of all electrical tests will be recorded. Any unacceptable conditions will be reported to the appropriate office for resolution.

*d.* Grounding system material will be in accordance with NFPA 70, Article 250, Part J, paragraphs 250-91 through 250-99, inclusively.

## 17–14. Earth electrode subsystem

The earth electrode subsystem establishes the electrical connection between the facility and earth. This connection is necessary for static electricity dissipation, useful in power fault protection, and aids in minimizing electronic noise from communications and instrumentation. It is a network of electrically interconnected rods and/or cables installed to establish a low resistance contact with earth. Electrodes are usually buried or driven beneath the earth's surface. Older garrisons or installations may also find that buried metal plates, cones, pipes, grids, wells, and/or grounded railroad tracks are used as the earth electrode subsystem. Only ground rods, ground loops, combinations, and variations thereof and salt water grounds are authorized for new construction or major renovation projects.

*a. Earth electrode subsystem general requirement.* Earth electrodes will be placed at uniform intervals about the protected facility as required; grouping of earth electrodes on one side of a facility is prohibited. Earth electrodes will be set not less than 3 feet or more than 8 feet from the structure. The type and size of the earth electrode subsystem will depend on local soil conditions. Test borings and/or soil resistance tests performed in the areas before construction will be used for deciding on an adequate earth electrode system. All connections will be tested for electrical resistance, and the entire earth electrode subsystem will be tested to assure that resistance to earth meets the requirements of table 17–1.

*b. Designing or renovating earth electrode subsystems.* The subsystem must be tailored to reflect the characteristics of the site and requirements of the facility. It must be properly installed and steps must be taken to assure that it continues to provide a low resistance connection to earth throughout the life of the facility. To achieve these objectives—

(1) Before beginning the design, conduct a survey of the site where the earth electrode subsystem is to be installed. Through this survey, determine the resistance of the soil, identify significant geological features, gather information on architectural and landscape features which may influence the design of the subsystem, and review local climate effects. (If possible, conduct this survey in advance of the final site selection to avoid particularly troublesome locations.)

(2) As the first step of the site survey, measure the resistance of the soil at several points over the area of the planned facility. Even the smallest facility, in so far as the earth electrode subsystem is concerned, will affect an area at least 15 meters by 15 meters (50 feet by 50 feet). For larger facilities, the area is assumed to extend at least 6 meters (20 feet) beyond the basic building or structural outline; that is, the ground floor plan. The soil resistance must be known over the area encircled or covered by the earth electrode subsystem.

(3) Design an earth electrode subsystem appropriate for the site.

(4) Install the subsystem in accordance with the recommended procedures.

(5) Finally, measure the resistance to earth of the subsystem to verify that it meets the goals or design specifications.

*c. Selection of earth electrode type.* Only ground rods, ground loops, combinations and variations thereof, and salt water grounds are authorized for new or renovation projects.

(1) Acceptable resistances to earth values are easiest to achieve when ground rods are driven to the depth determined by the soil resistance test.

(2) A ground loop (counterpoise) subsystem will be installed if one of the following conditions are met:

*(a) General requirements.* The minimum numbers of ground rods are driven to the depth determined by the soil resistance test and the required resistance to earth value is not achieved.

*(b) Grounding system other than lightning protection.* Drive, as a minimum, two additional ground rods (see table 17–2 for minimum ground rod requirements) to the depth determined by the soil resistance test. Acceptable resistances to earth values are still not achieved on two of three driven rods.

*(c) Grounding systems for lightning protection system.* Drive, as a minimum, one additional ground rod (see table 17–2 for minimum ground rod requirements) to the depth determined by the soil resistance test. Acceptable resistances to earth values are still not achieved on two of three driven rods.

*(d) Excessively long ground rods.* The results of the soil resistance test and cost analysis may indicate that installing ground rods would not be cost effective due to the need for excessively long ground rods. The results of the soil resistance test and cost analysis must be kept on file.

(3) Access to the earth electrode subsystem will be provided by installing one or more grounding wells at each new facility or at facilities undergoing major renovation. Acceptable types of grounding wells are shown in figure 17–1.

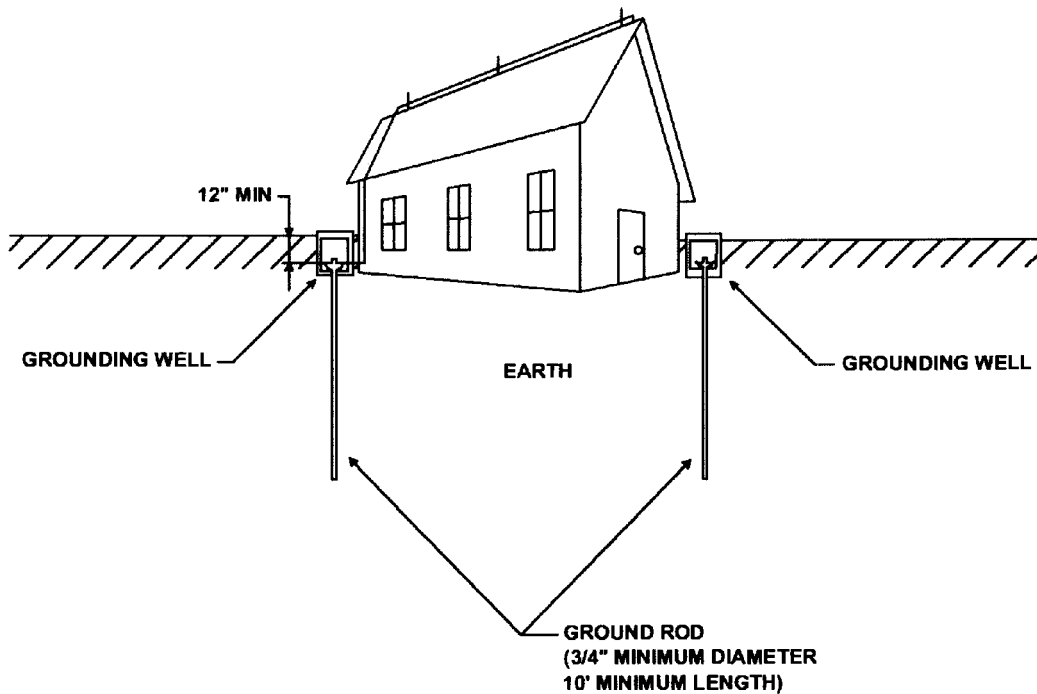

Figure 17-1. Typical ground rod installation

*d. Bonding requirements.*

(1) Bolted clamp connectors are the only permissible bonding method in grounding wells.

(2) All earth electrode subsystems protecting a facility will be bonded together. However, the following criteria applies where an earth electrode subsystem is installed and bonded to the existing earth electrode subsystem:

(a) All earth electrode subsystems will meet the most stringent resistance to earth value required for that facility.

(b) All earth electrode subsystems will be bonded together when maintenance is performed on the facility's grounding system.

(c) When a facility is renovated, all earth electrode subsystems will be bonded together.

*e. Visual inspection requirement.* (See para B-2 and table 17-1.)

*f. Electrical test requirements.* (See para B-4 and table 17-1.)

*g. Ground rods.* (See figs 17-2 and 17-3.) Ground rods are any vertical rods or pipes driven into the ground. Ground rods are normally used where bedrock is more than 10 feet below grade.



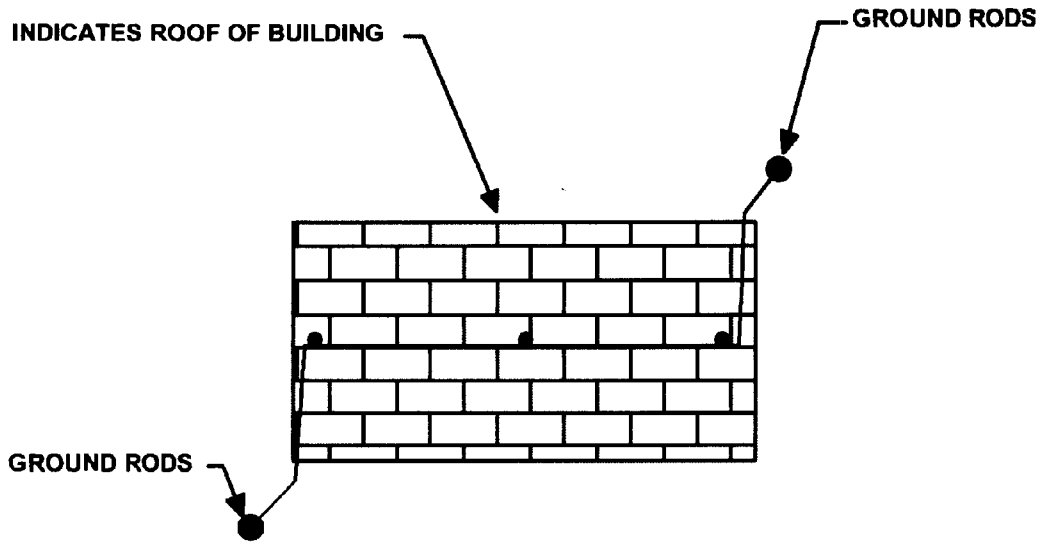

Figure 17-2. Typical multiple ground rod installation

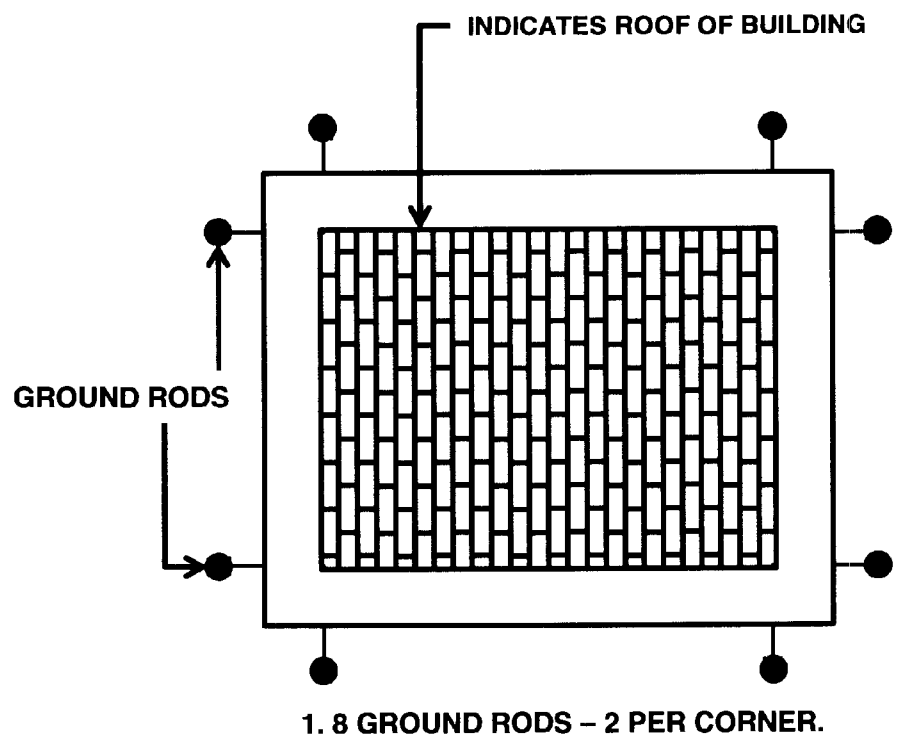

Figure 17-3. Typical ground loop installation

(1) *New installation or renovation requirements.*

(a) Ground rods will meet the requirements of NFPA 70 except when bonded to a lightning protection subsystem. They then will not be less than three-quarters of an inch in diameter and 10 feet in length. Rods will be copper-clad steel, solid copper, or stainless steel. Ground rods will be free of paint or other non-conductive coating. Ground rods will be located clear of paved surfaces, walkways, and roadways. Rods will be driven so that the tops are at least 12 inches below finished grade, and located 3 to 8 feet beyond the perimeter of the building foundation. Shallow topsoil over bedrock or dense coral may make it impractical to bury ground rods or a counterpoise to the required level below grade. In these instances, using extended down conductors or buried open plates as described in chapter 4 of NFPA 780 provides an acceptable alternative to vertical burial of 10' long rods. Drive stud bolts protect threaded area of rods when driving the rods into the ground. Threaded couplings will be used when it is necessary to drive multiple lengths of ground rods into the earth.

(b) Ground rod quantity requirements. (See table 17-2.)

(2) *Visual inspection requirements.* (See para B-2 and table 17-1.)

(3) *Electrical test requirements.* (See para B-4 and table 17-1.)

h. *Ground loop (counterpoise).* (See figs 17-4 and 17-5.) Ground loops consist of one or more buried cables (primary and secondary girdles) that completely encircle a facility.

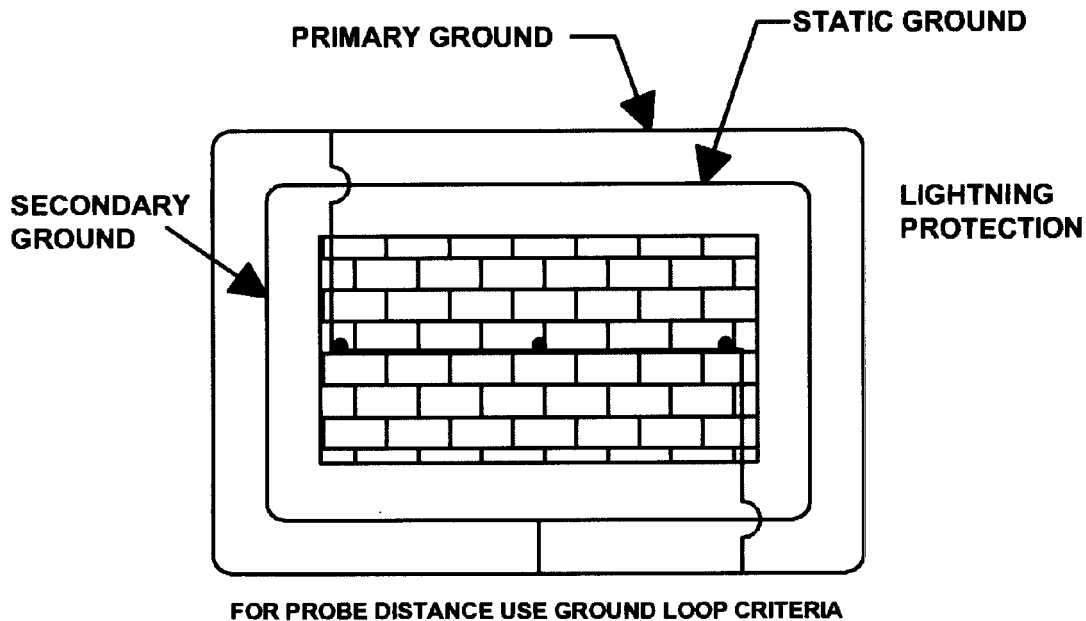

Figure 17-4. U.S. Navy designed earth electrode subsystem

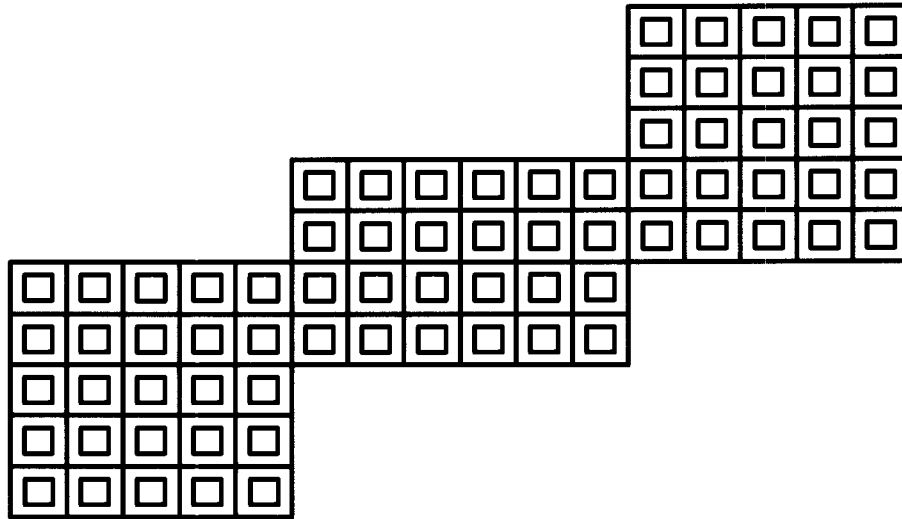

Figure 17-5. Typical grid installation

(1) *New installation or renovation requirements.* Ground loop cable will not be less than 1/0 American Wire Gage (AWG) stranded copper or copper clad steel cable. The size of any strand will not be less than 17 AWG. In areas where the soil is highly corrosive, larger cable will be used. The cable will be buried not less than 30 inches below grade and not less than 3 feet or more than 8 feet from the building foundation or footing. All bends in the cable will not be less than 90 degrees. A minimum of two ground rods are required with a ground loop. One ground rod will be installed at each diagonal corner of the ground loop. (Existing ground loop systems built under Navy specifications may have separate masts at each of the four corners of the ground loop with two each ground rods at each mast. This configuration meets Army standards.)

(2) *Visual inspection requirements.* (See para B-2 and table 17-1.)

(3) *Electrical test requirements.* (See para B-4 and table 17-1.)

i. *Grid.* A grid (see fig 17-5) is a system of buried interconnecting ground wires (cables) forming uniform rectangles either around or under a protected facility or group of facilities.

(1) *New installation or renovation requirements.* A grid system will not be used when building new explosives facilities. Existing grid systems will be maintained using the same criteria defined for new installation or renovation of ground loop subsystems.

(2) *Visual inspection requirements.* (See para B-2 and table 17-1.)

(3) *Electrical test requirements.* (See para B-4 and table 17-1.)

j. *Radial systems.* A radial system (see fig 17-6) is a buried cable at each down conductor that extends radially from the facility.

(1) *New installation or renovation requirements.* Radial system will not be used in building new facilities. Existing radial systems will be maintained using the same criteria defined for new installation or renovation of ground loop subsystems.

(2) *Visual inspection requirements.* (See para B-2 and table 17-1.)

(3) *Electrical test requirements.* (See paragraph B-4 and table 17-1.)

k. *Plate, cone, water pipe, and railroad track systems.* The plate or cone system consists of a series of buried plates or cones attached to each down conductor at a facility. Water pipe or grounded railroad tracks systems also exist at some installations.

(1) *New installation or renovation requirements.* Plate, cone, water pipe, and railroad track systems will not be used in the construction of new facilities. When plate, cone, water pipe, and railroad systems become unserviceable, they will be replaced using ground rods or ground loop systems as appropriate.

(2) *Visual inspection requirements.* (See table 17-1 and para B-2.)

(3) *Electrical test requirements.* (See table 17-1 and para B-4.)

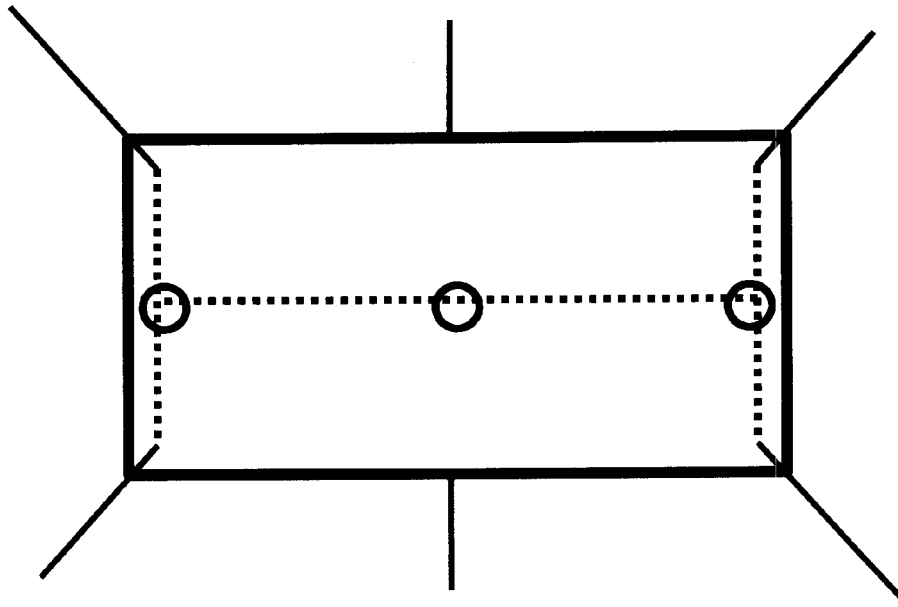

Figure 17-6. Typical radial installation

---

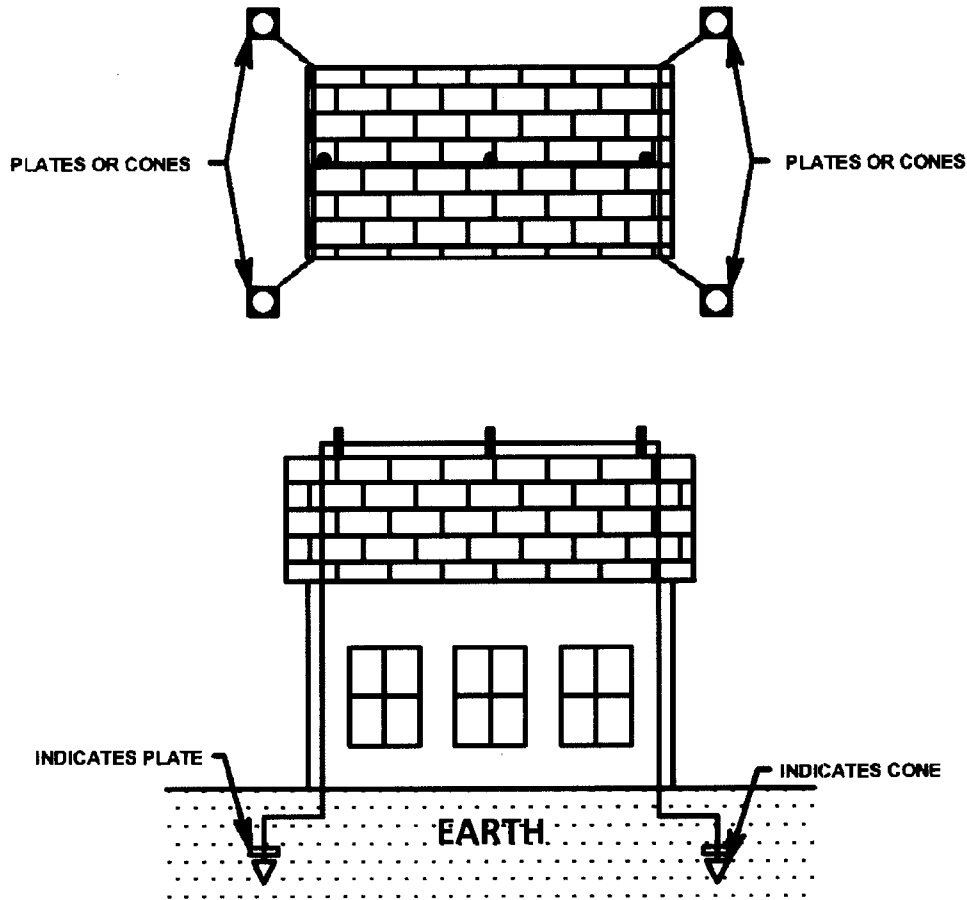

Figure 17-7. Typical buried plates or cones installation

## 17-15. Hazards of electromagnetic radiation to electroexplosive devices

### a. General requirements.

- (1) Unless a specific and valid exception has been authorized for the given hazard, use the criteria in this paragraph.
- (2) If technically qualified personnel at the local level cannot solve an electromagnetic hazard to EEDs, obtain consultation and measurement survey assistance from the higher headquarters through command safety channels.

### b. Electromagnetic radiation hazards.

(1) The EEDs are initiated electrically. One aspect of possible hazards is the accidental firing of EEDs by stray electromagnetic energy. A large number of these devices are initiated by low levels of electrical energy and are susceptible to unintentional ignition by many forms of direct or induced stray electrical energy, such as lightning discharges, static electricity, or triboelectric (friction-generated) effects, the operation of electrical and electronic subsystems onboard weapon systems, and radio frequency (RF) energy from ground portable and airborne emitters (transmitters).

(2) Lightning protection systems and requirements normally preclude the inadvertent initiation of EEDs by direct lightning strikes.

(3) Stray energy, such as, transients and other forms of induced energy, can be imposed upon circuits affecting EEDs from other subsystems by various methods. Examples are inductive or capacitive coupling from other cabling; sneak ground circuits; defective components or wiring; and errors in design, modification, or maintenance.

(4) The EEDs are susceptible to initiation by exposure to the radiated fields of RF emitters. The degree of susceptibility depends on many variables. These variables are the threshold firing level of the EED; the ability of the

leads, circuit, or installation to capture RF energy; the type and characteristics of RF energy; and methods of coupling which can introduce this energy into the EED.

*c. Safe separation distance criteria.* The separations given in table 17-3 should be used as a guide in setting up safe separation distances between EEDs and the transmitting antenna of all RF emitters. (More accurate distance calculations can be made using the procedures in figure 17-8 and para 17-15g, below.) These criteria apply generally to critical areas involving explosives assembly, disassembly, testing, loading, and unloading operations. The distances are based on a worst case situation; that is, most sensitive EEDs presently in the inventory, unshielded, having leads or circuitry which could inadvertently be formed into a resonant dipole, loop, or other antenna. Where EEDs are in less hazardous configurations, use the procedures outlined in d below.

*d. Shorter distance considerations.* A lesser safe separation distance may be allowed when EEDs are not in an exposed condition. Before the safe separation distance is reduced, there must be an analysis of local conditions, type of operations, and the inherent RF protection afforded EEDs in a given situation. Use the formulas in figure 17-8 for calculating safe separation distances from EEDs in specific configurations. Other possible configurations are:

- (1) For unknown worst case situations or exposed EEDs, use figure 17-8 (Unshielded munitions).
- (2) The EEDs may be stored or transported in metal containers with their leads twisted (shorted) together. Such items normally would be safe in almost any military electromagnetic environment; however, due to discontinuities, thickness of metal, or nonconducting gaskets the inherent shielding effectiveness of the container may be degraded. Use figure 17-8 (Shielded munitions), to calculate recommended safe separations and power densities.
- (3) For EEDs stored or transported in nonmetallic containers with their leads twisted (shorted), use figure 17-8 (Unshielded munitions) to calculate recommended safe separations and power densities.

*e. Precautionary procedures.* Leave EEDs in their containers until ready for use. Be careful not to untwist leads into the form of a resonant dipole, loop, or other effective antenna. Do not remove shorting clips until the EED is actually ready to be installed.

*f. Power density criteria.* When electrical characteristics of the EEDs in question are not known or when the minimum safe separation distances cannot be complied with because of lack of real estate or other limitations, a power density/field intensity survey should be made. These measurements are more exacting methods of determining a hazard, since actual conditions are involved rather than worst case conditions which are assumed for distances in table 17-3.

*g. Minimum safe distance.* When using the data from table 17-3 and figure 17-8, the following minimum safe distance information is to be used:

- (1) A minimum safe distance of 1.5 meters (5 feet) is allowed for citizens band radios (walkie-talkies) (26.96 to 27.23 MHz) which have less than 5 watts in power.
- (2) A minimum safe distance of 21 meters (69 feet) is allowed for 2-way mobile units in VHF (150.8 to 161.6 MHz) and 13 meters (43 feet) for 2-way mobile and fixed station units in UHF (450 to 460 MHz), which have less than 180 watts in power.
- (3) A minimum safe distance of 88 meters (290 feet) is allowed for major VHF 2-way mobile and fixed station units in 35 to 44 MHz range which have less than 500 watts in power.
- (4) A minimum safe distance of 35 meters (115 feet) is allowed for VHF 2-way fixed units in 150.8 to 161.6 MHz range which have less than 600 watts in power.

*h. Necessary information.* When using the data from table 17-3 and figure 17-8, the following information is to be used:

- (1) Maximum power to amateur radio mobile units is 1,000 watts.
- (2) The maximum power for some base stations in 42 to 44 MHz band and 1.6 to 1.8 MHz band is 10,000 watts.
- (3) The present maximum power for channels 2 to 6 and FM is 100,000 watts.
- (4) The present maximum power for channels 7 to 13 is 316,000 watts.
- (5) The present maximum power for channels 14 to 83 is 5,000,000 watts.

*i. Cellular telephones.* Cellular telephones should not be present within ten feet of unpackaged, electrically-primed ammunition. Specific policy with regard to cell-phone usage in ammunition areas is at the discretion of local commanders.

**Table 17–1  
Grounding system inspection and test requirements**

Grounding system component	Visual inspection interval	Electrical test interval	Required resistance
Earth electrode subsystem <sup>1,2,3,4</sup> ground rods, ground loop, grid, radial, plate, cones, railroad track, water pipes	12 months	2 years	25Ω
Static electricity charge dissipation subsystem	Daily before use	2 years	25 kΩ to 1 MΩ
Conductive floors, mats, table, tops, plates, runners <sup>9</sup>	6 months	2 years	25 kΩ to 1 MΩ
Metal mats <sup>8,9</sup>	6 months	2 years	25 kΩ to 1 MΩ
Conductive footwear, in use (on wearer) <sup>9</sup> Series connection	Daily before use	Daily before use	25 kΩ to 1 MΩ
Conductive belts, Conveyer belts	Daily before use	6 months	5Ω M max
V belts	Daily before use	At installation	600 kΩ max at initial installation
Conductive hoses	Daily before use	6 months	250 k max
Legstats <sup>9</sup>	Daily before use	Daily before use	25 kΩ to 1 MΩ
Wriststats <sup>5,9</sup>	Daily before use	Daily before use	1 M Ω max
Forklifts <sup>7</sup> , Aircraft loading pads	12 months	12 months	10kΩ
Equipment & machinery <sup>10</sup>	Daily before use	6 months	2Ω
Ordnance ground subsystem	12 months	24 months	25Ω
Instrument ground subsystem	12 months	24 months	25Ω
Lightning protection subsystem (bonding check)	12 months	24 months	1Ω

Notes:

<sup>1</sup> Only visible/accessible portions of the earth electrode subsystems will be inspected.

<sup>2</sup> In addition to the regular inspection/test interval, earth subsystems will be tested after initial installation, maintenance or renovation.

<sup>3</sup> The required resistance value is determined by what the earth electrode subsystem is bonded to. When more than one subsystem is bonded together, the most stringent requirement applies.

<sup>4</sup> Ground loop systems are required to exhibit a resistance to earth less than or equal to 25 ohms. When a higher resistance is measured, the test crew will perform a full three-point fall-of-potential test to determine if optimum probe locations will lower the result to an acceptable level. If the result is still above 25 ohms, the test crew will perform a four-point earth resistance test to determine if the high reading is due to soil conditions. If high soil resistance is the reason for the high initial reading, record this fact in the test record, and use this soil resistance reading for a new baseline value for future tests to detect any system deterioration. If the soil resistance is not the reason for the high resistance to earth, perform system maintenance.

<sup>5</sup> Testing of wriststats shall be conducted with a wrist strap tester or an appropriate digital readout ohmmeter. Wrist strap testers shall be used in accordance with the manufacturer's instructions.

<sup>6</sup> Forklift inspection and test procedures are in TB 43–0142. (MIL–T–21869 provides procedures for testing forklift discharge straps.)

<sup>7</sup> The inspection and test procedures are found in the following appendixes:

<sup>8</sup> a. Appendix B, earth electrode subsystems;

<sup>9</sup> b. Appendix C, static electricity dissipation subsystems;

<sup>10</sup> c. Appendix D, lightning protection subsystems (bonding tests).

<sup>11</sup> Test from one point on the metal mat to ground. It may be necessary to install a resistor between the metal mat and ground to achieve the required resistance.

<sup>12</sup> When utilizing electrically energized tools/equipment (110V or 220V), ground fault interrupters (GFIs) must be installed in the electrical circuits for personnel protection.

<sup>13</sup> Equipment bonds will be visually inspected together with scheduled or unscheduled maintenance entries into the bay area for operations that are continuous (three shifts, 24 hours per day), remotely controlled, conducted in separate bays, and can potentially create toxic atmospheres within the operating bay.

**Table 17-2  
Ground rod quantity requirements**

Type of system	Minimum number of ground rods
Power	1
Fault	1
Instrument	1
Ordnance	1
Static	1
Communication	1
Lightning protection	2
Structure	2

**Table 17-3  
Minimum safe distance from transmitter antennas**

Average or peak transmitter power in watts	Minimum distance to transmitter Meters	Minimum distance to transmitter Feet
0 - 30	30	98.4
31 - 50	50	164.1
51 - 100	110	360
101 - 250	160	525
251 - 500	230	755
501 - 1,000	305	1,000
1,000 - 3,000	480	1,575
3,001 - 5,000	610	2,001
5,001 - 20,000	915	3,002
20,001 - 50,000	1,530	5,020
50,001 - 100,000	3,050	10,007
100,001 - 400,000	6,100	20,014
400,001 - 1,600,000	12,200	40,028
1,600,001 - 6,400,000	24,400	80,056

Notes:

<sup>1</sup> When the transmission is a pulsed or pulsed continuous wave type and its pulse width is less than 10 microseconds, the power column indicates average power.

<sup>2</sup> For all other transmissions, including those with pulse widths greater than 10 microseconds, the power column indicates peak power.



UN-SHIELDED MUNITIONS		SHIELDED MUNITIONS	
UP TO 2.3 KHz	$D = 0.093\sqrt{PG}$	UP TO 73 KHz	$D = 0.093\sqrt{PG}$
2.3 KHz to 450 KHz	$D = 39.7F\sqrt{PG}$	73 KHz to 450 KHz	$D = 1.26F\sqrt{PG}$
450 KHz to 400 MHz	$D = 18\sqrt{PG}$	450 KHz to 400 MHz	$D = 0.6\sqrt{PG}$
400 MHz to 75,000 MHz	$D = \frac{7137}{F}\sqrt{PG}$	400 MHz to 2,400 MHz	$D = \frac{226}{F}\sqrt{PG}$
ABOVE 75,000MHz	$D = 0.093\sqrt{PG}$	ABOVE 2,400 MHz	$D = 0.093\sqrt{PG}$

Notes:

<sup>1</sup> Variables:

<sup>2</sup> D=Safe separation distance to transmitter in feet.

<sup>3</sup> P=Output power to transmitter in Watts.

<sup>4</sup> G=Numerical gain of transmitter antenna.

<sup>5</sup> F=Frequency in MHz.

<sup>6</sup> TABLE ASSUMES:

<sup>7</sup> NO-FIRE CURRENT=10 mA.

<sup>8</sup> SAFETY FACTOR=10dB or 3.61 (numerical).

<sup>9</sup> EED's LEADS=Tuned to match the transmitter's frequency.

<sup>10</sup> SHIELDING=If metallic, it provides a minimum of 30 dB or 32 times (numerical) of shielding. Non-metal packs provide no shielding.

<sup>11</sup> At no time, should personnel or munitions be exposed to more than 200 volts/meter (rms).

Figure 17-8. Safe separation distance equations

## Section IV

### Lightning Protection

#### 17-16. Fundamental principles of lightning protection

a. The fundamental principle for protecting life and property against lightning is to allow a lightning discharge to enter or leave the earth without resulting damage or loss. A low impedance path should be offered, which the discharge current will follow in preference to all alternative high impedance paths offered by building materials such as wood, brick, tile, stone, or concrete. When lightning follows the higher impedance paths, damage may be caused by the heat and mechanical forces generated during the passage of the discharge. Most metals, being good electrical conductors, are virtually unaffected by either heat or the mechanical forces if they are large enough to carry the current that can be expected. The metal path must be continuous from the earth electrode system to the air terminal. Care should be exercised in selecting metal conductors (see table 17-5) to ensure the integrity of the lightning conductor for an extended period. A nonferrous metal such as copper or aluminum will provide, in most atmospheres, a lasting conductor free of the effects of rust or corrosion.

b. Parts of structures most likely to be struck by lightning are those that project above surrounding parts such as chimneys, ventilators, flagpoles, towers, water tanks, spires, steeples, deck railings, antennas, shaft-houses, gables, skylights, dormers, ridges, and parapets. The edge of the roof is the part most likely to be struck on flat-roofed buildings.

c. An LPS consists of three basic parts that provide the low impedance metal path required—

- (1) A system of air terminals or overhead wires on the roof and other elevated locations,
- (2) A system of earth electrodes, and,
- (3) A conductor system (down conductor) connecting the air terminals to the earth electrode system.

d. Properly located and installed, these basic components described in paragraph c, above, improve the probability that the lightning discharge will be conducted harmlessly between the air terminals and the ground terminals.

#### 17-17. Locations requiring an lightning protection system

a. Lightning protection systems will be installed on all facilities. Facilities are structures or locations used for development, manufacturing, testing, handling, storage, inspection, holding, or maintenance of ammunition or explosives.

- b.* An LPS will be required at a demilitarization or disposal site only if—
  - (1) Personnel are required to work or remain at the site during the approach of or during a lightning storm; and,
  - (2) The garrison or installation commander determines an LPS is necessary to protect personnel or equipment.
- c.* Underground storage (see chap 11) with metal or structural parts that have less than 2 feet of earth cover will be protected as an aboveground site.

### **17–18. Locations not requiring lightning protection**

Under conditions specified in the following subparagraphs, lightning protection may be omitted from certain ammunition or explosives facilities. If lightning protection is not installed on a facility, the reasons for not protecting the facility shall be documented and kept with related site approval documentation. Bonding and surge suppression requirements still apply.

*a.* An LPS may be omitted on facilities equipped with an adequate lightning warning system (see para 17–23) when all the following conditions can be met—

- (1) Operations can be terminated before the storm strikes;
- (2) All personnel can be evacuated to IBD; and,
- (3) The expected damage due to a lightning strike will not seriously affect the garrison or installation mission.

*b.* An LPS may be omitted on facilities without a lightning warning system where—

- (1) Personnel are not expected to sustain injury; and,
- (2) The resulting economic loss of or to the facility, its contents, or surrounding facilities is minimal.

*c.* Lightning protection may be omitted on facilities that—

- (1) Contain only ammunition and explosives that cannot be initiated by lightning;
- (2) As determined by USATCES and approved by DDESB; and
- (3) No fire hazard exists.

### **17–19. Requirements for lightning protection systems**

*a.* This paragraph provides the minimum technical requirements for lightning protection of structures and areas containing explosive materials.

*b.* All LPSs designed to protect structures or areas containing explosives and energetic materials must provide a 100-foot zone of protection (see app H). This works on the principle that a sphere with a radius of 100 feet when it is placed on an LPS, will not touch the structure or object being protected as the sphere is rolled from protective point-to-point. It also will not touch the structure or object being protected before the sphere touches the ground.

*c.* All LPSs will have at least two conductive paths to ground. If the structure has a perimeter exceeding 250 feet, there will be a down conductor for every 100 feet of the perimeter or fraction thereof.

*d.* All LPSs will be bonded into the earth electrode subsystem of the facility being protected.

*e.* Down conductors may be coursed through the air without support for a distance of 3 feet or less. Down conductors that must be coursed through air for longer distances will be provided with a positive means of support that will prevent damage to or displacement of the conductor.

*f.* All new and renovated LPSs will be designed and constructed in accordance with TM 5–811–1, TM 5–811–3, and TM 5–811–7.

*g.* The following subparagraphs contain guidance regarding locations and heights of air terminals that may be used to achieve the required 100-foot zone of protection on concrete or steel arch earth-covered magazines. Other configurations are also considered to provide the 100-foot zone of protection if they were reflected in safety submissions or standard drawings approved by the DDESB after 1984. Garrisons or installations must determine if alternative configurations on older magazines afford the 100-foot zone of protection. Where an LPS installed before 1984 does not meet that criterion, it must be programmed for repair. The LPS repair program must prioritize corrective actions based on a hazard analysis of each violation consistent with DA Pam 385–10. First priority will go to correcting deficiencies on facilities storing chemical ammunition (chemical surety material as defined in DA Pam 385–61, exclusive of ton containers). Assistance in evaluating existing alternative arrangements or air terminals may be obtained through command safety channels. Alternative configurations for new magazines must be approved by site plans or safety submissions before construction.

(1) An earth-covered magazine up to 40 feet in length can be protected by a system with two air terminals.

*(a)* For this configuration, one air terminal must be placed on the top center of the headwall.

1. The front air terminal must extend at least 24 inches above the headwall.

2. The other air terminal must be placed at the rear of the magazine on or close to the rear ventilator stack.

*(b)* If the rear air terminal is mounted on the ventilator stack (either the ventilator cap or concrete stack), it must extend at least 24 inches above the top of the ventilator cap.

*(c)* If the rear air terminal is not mounted on the ventilator stack, add one additional inch in height to the terminal over and above the minimal 24-inch extension above the ventilator for every inch it is mounted away from the stack.

*(d)* The metal ventilator cap must be bonded to the lightning protection system.

(e) An air terminal less than 24 inches in height above the ventilator is acceptable provided protection consistent with the 100-foot striking arc can be demonstrated. However, the rear air terminal may never be less than 10 inches above any metal ventilator.

(2) An earth-covered magazine more than 40 feet, but not more than 80 feet, in length can be protected by three air terminals.

(a) For this configuration, a front and rear air terminal must be mounted as described for 40-foot magazines in paragraph g(1), above.

(b) A third air terminal is required on the top center of the magazine. The center air terminal must be at least 24 inches in length.

(3) An earth-covered concrete or steel arch magazine more than 80 feet in length could be protected by a front and rear air terminal as described for 40-foot magazines, and multiple air terminals between the front and rear that extend 24 inches above the headwall top surface. In this configuration, the air terminals must be equally spaced (but not more than 40 feet apart) along the crest of the arch.

h. Ammunition facilities, other than ECMs, with integral systems have the following minimal requirements—

(1) Air terminals will be at least 24 inches high.

(2) Air terminals are required on or close to ventilator stacks and caps. Those terminals must be at least 24 inches high and extend at least 10 inches above the ventilators they protect.

(3) Air terminals will be spaced not to exceed 25 feet apart on ridges, parapets, and around the perimeter of roofs.

(a) Where it has been necessary to exceed this spacing, the terminals shall be increased by 2 inches for each foot of increase over the 25 feet spacing between terminals.

(b) For large roof areas, additional air terminals may be required on the roof surface to achieve the 100-foot zone of protection.

(c) A grid of 24-inch air terminals on 25 foot centers (approximately 35 feet between terminals diagonally) will protect a horizontal roof surface.

i. Special requirements for integral systems are as follows:

(1) Air terminals will be at least 5 feet high above open or hooded vents emitting explosives dusts or vapors under natural draft.

(2) Air terminals will be at least 15 feet above open or hooded vents when explosives dusts or gases are emitted under forced draft.

## 17–20. Types of lightning protection systems

The following LPSs are listed in the NFPA and are the only ones currently approved for use:

a. *Integral system (lightning rods)*. An integral system consists of air terminals mounted directly on the structure to be protected, down conductors, and a grounding system. This system is used to protect structures. Air terminal spacing will meet the requirements of the 100-foot zone of protection (see app H). Metallic building components which are at least 3/16 inches thick may be used as down conductors.

b. *Mast system*. A mast system consists of an air terminal (lightning rod) on a mast, down conductors, and an earth electrode subsystem. This system can be used to protect either structures or areas. Masts will be separated by a minimum of 6 feet from the building or stack of munitions being protected.

c. *Catenary system (overhead wire)*. A catenary system consists of one or more overhead wires strung between masts and connected to a grounding system. This system is normally used to protect large open areas, such as a truck holding yard, but may also be used to protect structures..

(1) Masts of wood, used either separately or with ground wires, shall have an air terminal extending at least two feet above the top of the pole, attached to the pole as in figure 17–8, and connected to the grounding system.

(2) As an alternative, an overhead ground wire or a down conductor, extending above or across the top of the pole, shall be permitted to be used.

(3) In the case of an overhead ground wire system, the pole guy wire shall be permitted to be used as the down conductor.

(4) For grounded metallic masts, the air terminal and the down conductor shall not be required.

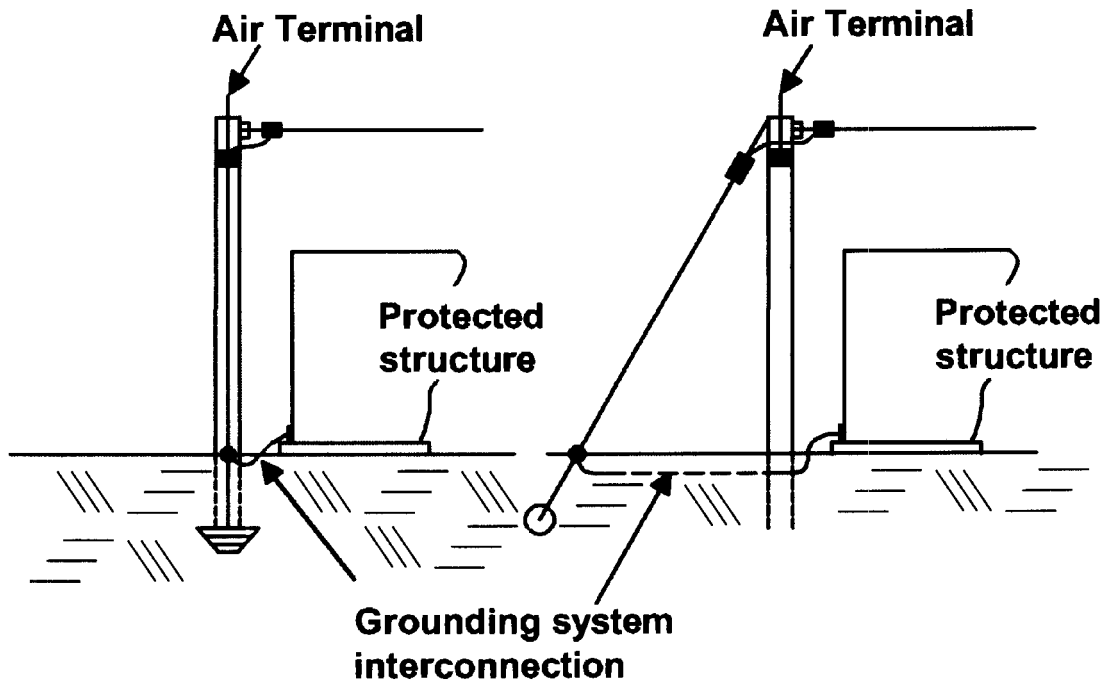

Figure 17-9. Alternate grounding methods for overhead ground wire protection

### 17-21. General prohibitions

*a.* When aluminum is used, the following applies:

(1) Aluminum lightning protection equipment will not be installed on copper roofing materials or other copper surfaces or where exposed to runoff from copper surfaces.

(2) Aluminum materials will not be used where they come into direct contact with the earth. Fittings used to connect aluminum down conductors to copper or copper-clad grounding equipment will be bimetallic. Bimetallic connectors will be installed at 18 inches or higher above the earth level.

(3) Connectors and fittings will be suitable for use with the conductor and the surfaces on which they are installed. Bimetallic connectors and fittings shall be used for splicing or bonding dissimilar metals.

(4) An aluminum conductor will not be attached to a surface coated with alkaline-base paint, embedded in concrete or masonry, or installed in a location subject to excessive moisture.

*b.* Copper lightning protection materials will not be installed on aluminum roofing, siding, or other aluminum surfaces.

*c.* Galvanized steel will not be used in areas where atmospheric conditions are destructive to galvanized steel. Where galvanized steel conductors are used, the individual wires of the cable will have a protective coating of zinc (hot-dipped process). This treated cable must be capable of withstanding four 1-minute immersions in a standard copper sulfate solution without showing a fixed deposit of copper.

*d.* Where copper-clad steel is used, the copper covering will be permanently and effectively welded to the steel core. The portion of copper will be such that the conductance is not less than 30 percent of the conductance of an equivalent cross-section of solid copper.

*e.* Stainless steel is very susceptible to corrosion in many soil conditions. Extreme caution will be used along with a proper soil analysis when this material is used. Records of the soil analysis will be kept as a permanent part of the lightning protection records.

*f.* Steel arch and reinforced concrete arch magazines with design discontinuities between the steel in the arch and the steel in the floor should not be used to store ammunition and explosives.

### 17-22. Bonding

*a.* Protection from side flash shall be obtained by either separation distance or by bonding. The required separation distance shall be determined by using the formula in NFPA 780, 'Standard for the Installation of Lightning Protection

Systems' as indicated below. Bonding is used to reduce the possibility of a side flash and is used to ensure no electrical potential differences are produced by lightning current. Chapter 4 and Annex K of NFPA 780 shall be used to determine the minimum bonding requirements except as modified herein.

*b.* For buildings which are 36 feet in height, or less:

(1) Bonding will be required for large masses of metal (400 inches square or larger surface area) located on the exterior, or within facilities,

(2) Bonding is also required if the object is within 6 feet of an opening or within six feet of any part of the LPS. Examples include facility metal items such as radiators, tanks, permanent machinery, stair rails, ventilator, metal doors, air conditioning ducts, metal columns and metal siding.

*c.* For buildings greater than 36 feet in height: Bonding will be required as specified in NFPA 780, chapter 3.

*d.* The material used to bond the LPS to the grounding loop conductor will meet the requirements set forth in table 17-5. The resistance of any object bonded to the LPS will not exceed one ohm. Exceptions are noted in table 17-1.

*e.* Fences which come within 6 feet of an explosives structure's LPS will be bonded to the structure's LPS or its grounding system.

*f.* Railroad tracks which run within 6 feet of an explosives structure's LPS will be bonded to the structure's LPS or its grounding system. If the tracks are used to carry electrical signals, they will have insulated joints immediately external to bond the LPS's ground loop conductor. If these tracks enter a facility, they will also be bonded to the frame of the structure or equivalent.

### **17-23. Lightning warning systems**

*a.* Lightning warning systems provide a positive, reliable means of continuously monitoring and recording atmospheric voltage gradient. They can detect atmospheric conditions that may produce lightning in the vicinity. Lightning warning systems that are installed and properly maintained can detect thunderstorms up to 200 miles away and indicate the direction of approach.

*b.* Garrisons or installations with lightning warning systems will establish specific criteria for terminating ammunition and explosives operations at the approach of a thunderstorm. These criteria will be based on the sensitivity of the operation involved and the amount of time required terminating operations safely. The lightning warning system shall allow ammunition and explosives operations to be terminated before the storm is 10 miles from the garrison or installation.

*c.* Garrisons or installations without lightning warning systems will also be required to develop criteria for evacuating ammunition facilities at the approach of a storm.

(1) The decision to terminate an operation and/or evacuate must be determined on a case-by-case basis pending an evaluation of the risks to operations and support personnel.

(2) Procedures should identify a responsible individual who can decide when evacuation is necessary. Following are some examples of facilities that should be evacuated in the event of a probable electrical storm—

*(a)* All operations involving EEDs and exposed explosives or propellants.

*(b)* Buildings containing explosives dusts or vapors, whether or not equipped with approved LPSs and locations within ILD of these facilities.

*(c)* Outdoor operations with unpackaged munitions or ammunition operations being conducted without lightning protection.

### **17-24. Structural grounds**

On all new construction and extensive renovation, the structural steel in all explosives facilities will be bonded to the facility grounding system. No greater than 1 ohm resistance will exist between the structural steel and the grounding system. Testing will be in accordance with appendix D, paragraph D-3.

### **17-25. Grounding**

For details on grounding, use table 17-5 and paragraph 17-13.

### **17-26. Surge protection**

*a.* An LPS for ammunition and explosives structures will use surge protection for incoming conductors meeting the requirements of UL 1449, Transient Voltage Surge Suppressors, and 2nd Edition.

*b.* These power and communication lines will enter the facility in underground shielded cables or in metallic conduits which enter the ground at least 50 feet from the facility. In addition, intrusion detection systems and other metallic lines will run underground for at least the last 50 feet up to the structure. Surge suppression for incoming conductors must include suppression at the entrance to the building from each wire to ground. The use of low-pass filters will be considered for added protection on specific critical electronic loads as determined by the user.

*c.* Fiber optic cables do not need to run underground before entering the building.

*d.* Steam, water, and air conditioning lines may run above ground as long as they are bonded to the structure's LPS

before entering the structure. If these lines are not bonded to the LPS, they will run the last 50 feet to the building underground.

#### **17-27. Visual inspection requirements**

- a. Components of the LPS will be visually inspected at intervals specified in table 17-1.
- b. Components of the LPS will be inspected in accordance with annex D, paragraph D-2.

#### **17-28. Electrical testing requirements**

- a. The LPS will be tested at intervals specified in table 17-1.
- b. The LPS will be tested per annex D, paragraph D-3.
- c. The resistance of any component of the LPS will not exceed the value specified in table 17-1.
- d. The resistance of any metal object bonded to the LPS will not exceed the values specified in table 17-1.
- e. Any standard ohm meter that is capable of reading 1 ohm with a manufacturer's certified accuracy of  $\pm 0.1$  ohm and capable of measuring bond connections for large facilities can be used. Analog meters can continue to be used but all newly procured meters must have a resolution of 0.1 ohm as well as the 1 ohm capability with an accuracy of  $\pm 0.1$  ohm.
- f. Some garrisons or installations have LPSs that are unique to their particular location. Compliance with all testing details as stated in this chapter may not be practical or possible due to variations in building features, unavailability of as-built drawings, or even terrain features (rock or concrete-covered ground near structures to be tested). When strict compliance for test and inspection of a facility cannot be accommodated, garrisons or installations must make maximum use of expertise available; for example, electrical engineers, at their command and develop a reasonable and well-documented LPS test and inspection plan within the guidance of this chapter. This plan will be forwarded to the garrisons or installations next higher headquarters for review and, once approved, retained with the garrison or installation's permanent LPS records.
- g. Earth-covered magazines that contain a metallic cage, as defined in NFPA 780, annex K, and that do not contain any energized or unbonded metallic penetrations, do not require earth-resistance testing.

#### **17-29. Records**

The inspection and test reports and/or records will be maintained in the garrison or installation safety office; unless an alternate office is specifically designated by the garrison or installation commander. Records of tests and inspections will be kept on file for the last six inspection cycles. These records will be reviewed for deficiencies and trend analysis. Significant variances will be analyzed to determine the cause and indicated repairs must be made.

#### **17-30. Truck holding areas**

For designated established truck holding areas, lightning protection must be applied. For undesignated truck holding sites used in support of field training exercises, lightning protection is not necessary if the following requirements are met:

- a. Explosives QD limits and vehicle separations are strictly enforced.
- b. Onsite security personnel are kept to a minimum.
- c. The sites are located away from lightning conductors and attractors.

#### **17-31. Lightning protection for empty facilities**

Empty ammunition and explosives facilities that have been inspected, certified empty and sealed (with numbered and recorded seals) will be considered as no longer used for development, manufacturing, testing, handling, storage, maintenance, demilitarization, and/or disposal of ammunition or explosives. These facilities will no longer require either a visual inspection or electrical test of the LPS as described in this chapter. All visual inspections and electrical tests required by this chapter will be performed before reactivating the ammunition and explosives facilities. This requirement is applicable to empty facilities at active garrisons or installations as well as facilities at garrisons or installations on the Base Closure List.

**Table 17–4**  
**Lightning protection systems<sup>6</sup>**

Item	Material	Size requirements	Restrictions
Ground rod	1. Copper 2. Copper-clad steel 3. Stainless steel <sup>2</sup> 4. Hot-dipped galvanized steel <sup>3</sup>	0.75 inch in diameter or larger; not less than 10 ft long	1. The top of the rod must be at least 12 inches below the finished grade. 2. Must be free of paint or other nonconductive coatings.
Ground loop (counterpoise)	1. Stranded copper 2. Copper-clad steel cable	Must be at least 1/0 AWG with no single strand less than 17 American Wire Gage (AWG) (0.045 inch) in size.	1. Must be at least 30 inches below the finished grade. 2. Must be located at least 3 ft, but not more than 8 ft from the building foundation or footing. 3. All bends in the cable must be not less than 90°.
Air terminal	1. Solid copper 2. Copper-clad steel 3. Hot-dipped galvanized steel <sup>3</sup>	1. Must be at least 24 inches high and extend at least 10 inches above the structure to be protected. 2. Must be 3/8 inch in diameter (Class I) <sup>4</sup> or 1/2 inch (Class II) <sup>5</sup> in diameter below the taper.	1. Air terminals will be either tapered to a sharp or blunt point. 2. Separate points are not required on top of air terminals; but, if they are used, they shall be substantial and securely attached by screw or slip joints.
Air terminal	1. Solid aluminum <sup>1</sup>	1. Must be at least 24 inches high and extend at least 10 inches above the structure to be protected. 2. Must be 1/2 inch in diameter (Class I) <sup>4</sup> or 5/8 inch (Class II) <sup>5</sup> in diameter below the taper.	1. Air terminals will be either tapered to a sharp or blunt point. 2. Separate points are not required on top of air terminals; but, if they are used, they shall be substantial and securely attached by screw or slip joints.
Catenary (overhead wire) system	1. Copper 2. Copper-clad steel 3. Aluminum <sup>1</sup> 4. Stainless steel <sup>2</sup>	1. A continuous run of wire. 2. Wire size to be determined by an engineering analysis based on the environment, installation needs, and the requirements of NFPA 780. 3. When an analysis is not available, 1/0 AWG is the required wire size.	1. Side flash separation distance and height of overhead wire above protected structure will be determined by using the requirements of NFPA 780. 2. Air terminals are required on non-metal poles (see air terminal).
Air terminals	1. Tubular aluminum <sup>1</sup> 2. Tubular copper	1. Must be at least 24 inches high and extend at least 10 inches above the structure to be protected. 2. Must have an outer diameter of at least 5/8 inch below the taper. 3. Minimum wall thickness will be 0.033 inch for copper and 0.064 inch for aluminum.	1. Air terminals will be either tapered to a sharp or blunt point. 2. Separate points are not required on top of air terminals; but, if they are used, they shall be substantial and securely attached by screw or slip joints.
Main conductor, cable	1. Copper	1. Minimum strand size is 17 AWG (0.045 inch) (Class I) <sup>4</sup> or 15 AWG (0.057 inch) (Class II) <sup>5</sup> . 2. The weight of the wire will be at least 187 lbs per 1,000 ft (0.187 lbs per foot) (Class I) <sup>4</sup> and 375 lbs per 1,000 ft (0.375 lbs per foot) (Class II) <sup>5</sup> .	1. The down conductor will be as nearly vertical as possible. 2. Bends will not be less than 90° with minimum radius of 8 inches.
Main conductor, cable	Aluminum <sup>1</sup>	1. Minimum wire size is 14 AWG (0.064 inch) (Class I) <sup>4</sup> or 13 AWG (0.072 inch) (Class II) <sup>5</sup> . 2. The weight of the wire will be at least 95 lbs per 1,000 feet (0.095 lbs per foot) (Class I) <sup>4</sup> or 190 lbs per 1,000 feet (0.190 lbs per foot) (Class II) <sup>5</sup> .	1. The down conductor will be as nearly vertical as possible. 2. Bends will not be less than 90° with minimum radius of 8 inches.

**Table 17-4**  
**Lightning protection systems<sup>6</sup>—Continued**

Main conductor, solid strip	Copper	1. The outside diameter will be at least 0.5 inch. 2. Minimum thickness will be 0.051 inch. 3. Minimum width will be 1 inch.	1. The down conductor will be as nearly vertical as possible. 2. Bends will not be less than 90° with minimum radius of 8 inches.
Main conductor, solid strip	Aluminum <sup>1</sup>	1. Minimum thickness will be 0.064 inch. 2. Minimum width will be 1 inch.	1. The down conductor will be as nearly vertical as possible. 2. Bends will not be less than 90° with minimum radius of 8 inches.
Bonding strap (solid or stranded)	Copper	1. Minimum wire size is 17 AWG (0.045 inch). 2. The weight of the wire will be at least 80 pounds per 1000 feet (0.080 pounds per foot). 3. Solid wire shall be a minimum of 6 AWG.	None
Bonding strap (solid or stranded)	Aluminum <sup>1</sup>	1. Minimum wire size is 14 AWG (0.064 inch). 2. The weight of the wire will be at least 128 pounds per 1000 feet (0.128 pounds per foot). 3. Solid wire shall be a minimum of 4 AWG.	None
Bonding strip	Copper	The strip will be at least 0.051 inch thick and 0.5 inch wide.	None
Bonding strip	Aluminum <sup>1</sup>	The strip will be at least 0.064 inch thick and 0.5 inch wide.	None

Notes:

<sup>1</sup> Where aluminum is used, care shall be taken not to use it in contact with the ground or elsewhere where it will rapidly deteriorate. Conductors will be electrical grade aluminum.

<sup>2</sup> Research has been presented that warns that stainless steel is very susceptible to corrosion in many soil conditions. A proper soil analysis will be conducted before using this type of rod.

<sup>3</sup> Galvanized steel will not be used in atmospheric conditions which are destructive to it.

<sup>4</sup> Class I specifications apply to buildings or structures 75 feet or less in height.

<sup>5</sup> Class II specifications apply to buildings or structures which exceed 75 feet in height.

<sup>6</sup> In OCONUS applications, metric equivalent dimensions are considered acceptable (for example, 3 meters = 10 feet).

<sup>7</sup> Unless otherwise noted, specifications in this chapter apply to Class I structures.

## Chapter 18

### Special storage procedures for waste military munitions

#### 18-1. Scope and applicability

*a.* The EPA promulgated the Munitions Rule (MR) (40 CFR Part 266 Subpart M) to define when chemical and conventional military munitions become hazardous waste and to provide for the safe storage and transportation of such waste. The MR sets forth two approaches for the storage of waste military munitions for storage that may exceed ninety days:

- (1) Conditional exemption (CE) from certain Resource Conservation and Recovery Act (RCRA) requirements,
- (2) A new RCRA storage unit standard (for example, 40 CFR Parts 264 and 265, Subpart EE).

*b.* This chapter establishes additional requirements for storage of waste military munitions.

#### 18-2. Certificates of risk, acceptance, waivers, and exemptions

*a. Conditional exemption storage.* Waivers, exemptions, and CORA's from DA Pam 385-64 are not authorized for ammunition and explosives storage facilities (for example, ASUs) storing CE waste military munitions.

*b. Resource Conservation and Recovery Act storage.* Waivers, exemptions, and CORA's from DA Pam 385-64 will only be available to units storing waste munitions under RCRA unit standards (for example, Subpart EE of 40 CFR Parts 264 and 265). After 31 December 1999, the ASA(I&E) must approve all such deviations, both existing and new. This approval authority may not be delegated.

#### 18-3. Requirements for storage of waste military munitions under conditional exemption

*a.* Garrisons, installations and responsible activities storing waste military munitions under CE must comply with 40



CFR 266.205(a).

*Note.* (The MR established CE does not apply to chemical agents or chemical munitions.)

*b.* Commands and DRUs will ensure that garrisons, installations, and responsible activities:

(1) Maintain records, for a minimum of 3 years from the last day the waste munitions were stored, that describes:

(a) The type of waste military munitions stored by standard nomenclature, lot number, Federal Supply Class (FSC), National Stock Number (NSN), Department of Defense Ammunition Code (DODAC), and condition code.

(b) The quantity of each type waste military munitions stored.

(c) The date that each military munitions, by type, was identified as waste.

(d) The last storage date for each, by type, waste military munitions.

(e) The storage location or locations (for example, building number or storage pad, and grid coordinates) used.

(f) The disposition (for example, destroyed, demilitarized, shipped) and date of action, by type, of the waste munitions.

(g) When applicable, the sending and receiving sites for those waste military munitions received from or shipped to off-site sources.

(2) Physically separate (for example, on a separate pallet or shelf) waste military munitions from non-waste military munitions when both are stored in the same ASU.

(3) Clearly mark the segregated waste military munitions to ensure proper identification.

(4) Store waste munitions under CE in ASUs that comply (without certificate of risk acceptance) with the provisions of this pamphlet. Each ASU storing waste military munitions or explosives under CE must be included in a DDESB-approved explosives safety site plan that the garrison or installation keeps on file. Those portions of the site plan addressing ASUs storing waste military munitions under CE shall be made available to appropriate Federal or State environmental regulatory authority upon request.

(5) Have SOPs or plans which are designed to provide safety, security, and environmental protection. These plans will be coordinated with the appropriate Federal, State, and local emergency response authorities (for example, law enforcement, fire departments, hospitals, and so forth), and established planning committees.

*c.* Loss of CE.

(1) The unpermitted or uncontrolled detonation, release, discharge, or migration (for example, loss, theft, as a result of fire or explosion) of waste military munitions out of any storage unit that might endanger human health or the environment will result in the immediate loss of CE for those waste military munitions. Incidents of this nature and the loss of CE require reporting per paragraph 18-5 below.

(2) The appropriate Federal or State environmental regulatory authorities may withdraw CE based on review or inspection of the garrison or installation's or responsible activity's compliance with the requirements for storage of waste military munitions under CE. Commands and DRUs may, at any time, restrict an activity from using CE. In addition, Commands and DRUs, upon discovery of a condition that could warrant loss of CE, will report the condition to the USATCES, HQDA G4, and the commander of the garrison or installation or responsible activity. Reports shall contain information as specified in paragraph 18-5, below.

(3) If CE is lost, the waste military munitions are subject to other RCRA hazardous waste regulations. The garrison, installation or responsible activities must obtain any required RCRA permits because of the loss of CE.

(4) Garrisons, installations and responsible activities may apply for reinstatement of CE per 40 CFR 266.205(c).

#### **18-4. Other storage standards**

*a.* Many States regulate waste management activities, including the storage of waste military munitions. In the event such State regulations conflict with DDESB or Army explosives safety standards, HQDA (G-4) shall attempt to resolve the conflict. For those issues that cannot be resolved:

(1) The DCS, G-4 shall notify the Chairman, DDESB, through the Army Board member, of any irreconcilable conflict of State law, regulation, or directive with these or other DOD or DA explosives safety standards.

(2) The Chairman, DDESB, will review the law, regulation, or directive for any potential impact on explosives safety and will assist the DCS, G-4, in coordination with the Deputy Under Secretary of Defense (Installations & Environment) (DUSD(I&E)), in resolving such regulatory conflicts.

*b.* Nothing in this paragraph shall affect the Army's right to seek review of the State law, regulation, or directive in a court of competent jurisdiction.

#### **18-5. Reporting**

*a.* Any non-permitted or uncontrolled detonation, release, discharge, or migration of waste military munitions out of any storage unit (for example, loss, theft, because of fire or explosion) that may endanger human health or the environment will be reported in accordance with AR 385-10, DA Pam 385-40, 40 CFR 266.205(a)(v)). The garrison, installation or responsible activity will also notify:

(1) Their chain of command;

- (2) USATCES;
- (3) The appropriate Federal or State environmental regulatory authority; and
- (4) Established local emergency preparedness committees.

b. Telephonic notification or, when notifying the chain of command and USATCES, electronic notification (via email (ES-Hotline@dac.army.mil) or facsimile (DSN 956-8503 Commercial (918)420-8503)) will be made within 24 hours.

c. A written notification will be provided within five days if the initial report was telephonic. These reports will comply with the requirements of DA Pam 385-40.

d. Follow-up reports are only required when pertinent information, which was not previously reported, becomes known. Follow-up reports will comply with the requirements of DA Pam 385-40.

#### **18-6. Closure of facilities storing waste munitions under CE**

a. *Explosive safety requirements.* In addition to the explosives safety requirements of paragraph 3-27—

(1) When an ASU that stored waste military munitions under CE is permanently taken out of service for the storage of non-waste and waste military munitions, garrisons, installations and responsible activities will ensure that such ASUs are appropriately closed.

(2) Garrisons, installations or responsible activities must notify the appropriate Federal or State environmental regulatory authority in writing at least 45 days before the closure activities begin. Initiation of these closure procedures should occur within 180 days after the date the decision is made to permanently stop using the ASU for the storage of military munitions.

(3) Within 90 days of closure completion, a “Certification of Closure,” must be submitted to the appropriate Federal or State environmental regulatory authority signed by the garrison, installation or responsible activity commander, or other equivalent level authority; and by an independent (that is, an individual not assigned within the commander’s or equivalent-level authority’s chain of command) registered professional engineer.

(4) The certificate of closure must state, at a minimum, that each of the explosives safety requirements set out in paragraph 3-27 have been met and that waste military munitions and residues are removed in such a manner as to protect the public and the environment consistent with the planned use of the ASU and of the property.

(5) If the garrison, installation or responsible activity cannot be rendered the closure certification, then they must contact the appropriate Federal and State environmental regulatory agency to determine the appropriate course of action.

b. *Discontinuance of use for the storage of waste munitions.* When an ASU that stored waste military munitions under CE will no longer store waste military munitions but will continue to store military munitions, the installation, garrison and responsible activity will ensure that all waste military munitions and residues are removed. After discontinuance of munitions waste storage, within 90 days of closure completion, notification must be submitted to the appropriate federal or state environmental regulatory authority signed by the garrison, installation or responsible activity commander, or other equivalent level authority. Storage is then reverted to munitions storage, a hazardous material operation covered by DODD 6055.9E.

#### **18-7. Closure of facilities storing waste military munitions under Resource Conservation and Recovery Act**

In addition to those explosives safety requirements in paragraph 3-27, closure procedures for those sites operating under existing RCRA permits will follow those closure requirements stipulated in the respective permit.

### **Chapter 19 Real Property Known or Suspected to Contain Munitions and Explosives of Concern**

#### **19-1. General**

This chapter implements DODM 6055.09-M, Volume 7. It also provides additional technical guidance on the explosives safety aspects of munitions response actions.

#### **19-2. Purpose and scope**

a. This chapter establishes criteria designed to protect human health and the environment from real property known or suspected to contain MEC; to establish a process to ensure that explosives safety is addressed throughout a munitions response to MEC; and to establish a process to obtain USATCES and DDESB approval of explosives safety submissions and explosives safety site plans associated with munitions responses to MEC. (For munitions responses at munitions response site (MRS) known or suspected to contain chemical munitions or chemical agents in other than munitions configurations, or chemical agent identification sets (CAIS) (referred to as CWM sites) see Interim Guidance for Chemical Warfare Material (CWM) Responses, dated 1 April 2009.)

*b.* This chapter applies to the following:

(1) Real property known or suspected to contain MEC. Real property consists of land (and water bodies thereon); and buildings, to include installed equipment (such as, process piping, ventilation ducting, drain piping). Real property may contain MEC as the result of munitions-related activities. Such activities include but may not be limited to live-fire training and testing, munitions production, renovation or demilitarization, including open burning and open detonation (OB/OD), and disposal activities (such as, land burial, sea disposal).

(2) Munitions responses conducted on MRS known or suspected to contain MEC. Such MRS may include the following:

- (a) Former ranges and training or maneuver areas.
- (b) Burial sites on operational ranges.
- (c) Former AE operating buildings, including installed equipment and related explosives waste discharge streams (for example, explosive sumps, explosive wastewater lines, explosive soil in ditches and settling ponds).
- (d) Formerly Used Defense Sites (FUDS).
- (e) Other property (such as, property adjacent to active installations), with the exception of operational ranges (see below), that may contain MEC as a result of activities conducted on the installation.

*c.* This chapter does not apply to the following:

(1) Munitions response activities (for example, preliminary assessments (PA) or site inspections (SI) when ground disturbing or other intrusive activities are not intended and intentional physical contact with MEC, including chemical munitions or chemical agent in other configurations, is not planned.

(2) Range clearance and maintenance activities on operational ranges (see DA Pam 385–63).

(3) Munitions responses on former ranges used exclusively for training with SAA.

(4) On-call construction support.

(5) Anomaly avoidance activities.

(6) Munitions or explosives emergency responses.

(7) Cleanup of AE operating buildings and installed equipment and associated waste discharge streams that are:

(a) Operating under a RCRA permit. (When the cleanup of such facilities is normally governed by closure requirements of a RCRA permit, an explosives safety submission is generally required for such activities.)

(b) In an active, standby, or layaway status.

(8) Biological warfare materiel.

(9) Munitions responses to an MRS known or suspected to contain CWM or CAIS (for example, CWM sites). (See Interim Guidance for CWM Responses, dated 1 April 2009.)

### **19–3. Identification and control of areas known or suspected to contain munitions and explosives of concern**

*a.* Army installations will maintain permanent records of:

(1) All property (for example, operational ranges, former ranges) known or suspected to contain MEC on installation master plans and maps. Records for these areas will identify the category of MEC (for example, UXO, Discarded Military Munitions (DMM) or munitions constituents (MC) in sufficient concentrations to pose an explosive hazard), the types of munitions known or most likely present, and, if known, the quantity, nomenclature and any known or suspected locations.

(2) Range firing records.

(3) Explosives or munitions emergency responses conducted at the site.

(4) Archival Search Reports (ASR).

(5) Any munitions response actions previously conducted at the site. Munitions response actions, include, but may not be limited to—

(a) Time critical removal actions (TCRA).

(b) Non-time critical removal actions (NTCRA).

(c) Remedial actions;

(d) Closure actions, if applicable, required for RCRA-permitted facilities (such as, OB/OD sites, AE manufacturing facilities).

*b.* Provide information as required for maintenance of the Army's MRS Inventory.

*c.* Ensure MEC records required by paragraph 19–3*a*, above, are maintained and transferred to appropriate records repositories should the installation become inactive or close. Request guidance from Installation Management Command (IMCOM) regional headquarters on disposition of MEC records.

*d.* Assume the following areas present explosive hazards associated with MEC:

(1) Operational range impact areas. Exception: ranges used exclusively for training or testing with SAA.

(2) Former ranges known or suspected to contain MEC.

(3) Outdoor demolition areas, to include areas used for OB or OD.

(4) Areas that are associated with AE production, demilitarization, renovation, or similar processes (for example, operating buildings and any installed equipment) that generated explosives residues (such as, dust, vapors, liquids) and that might have become contaminated with such residues in concentrations sufficient to present explosive hazards, to include areas receiving processing wastewater (or example, settling ponds, drainage swales).

*e.* Prohibit unnecessary access (for example, livestock grazing; recreational uses, such as hunting and hiking) and take appropriate action to deter unauthorized access to areas under Army or DOD control that are known or suspected of containing MEC. (Note: In some locations (for example, Texas), grazing may be authorized by agreement on a case-by case basis.)

(1) Establish risk-based actions, such as posting warning signs (bilingual, as required; pictograms are also recommended); establish access controls such as fences, roadblocks, or roving security patrols; and implement and maintain, when required, 3Rs (Recognize, Retreat, Report) explosives safety education (available at <https://www.denix.osd.mil/uxosafety>).

(2) Limit access to such areas, particularly operational range impact areas, to personnel who have an operational requirement to enter such areas (for example, range maintenance, environmental monitoring, and security). A risk assessment to evaluate the potential hazards (for example, category of MEC, type of AE, amount, and location-surface or subsurface—of MEC present) associated with the activity authorized shall be completed and methods to mitigate any potential exposures shall be implemented before allowing access. Develop guidelines to determine when individuals, who for operational reasons (for example, environmental monitoring), are authorized access to areas under Army or DOD control that are known or suspected to contain MEC, must be escorted into the area.

*f.* Prohibit the disposal (for example, burying, dumping) of AE on land or in water except when specifically authorized by the Secretary of the Army or a designated representative. This prohibition does not include the following:

(1) The covering of AE, including MEC, with earth or other material to control fragments, blast or noise during authorized destruction by detonation.

(2) The use of in-situ covering or capping of MEC when implemented as a remedy or response under an authorized response action.

#### **19–4. Identification and control of munitions response site known or suspected to contain munitions and explosives of concern at formerly used defense sites**

The DOD has designated the Secretary of the Army (SA) as the Executive Agent (EA) for DOD’s FUDS Program. The Deputy Assistant Secretary of the Army for Environment, Safety and Occupational Health (DASA(ESOH)) carries out these responsibilities on behalf of the SA. The U.S. Army Corps of Engineers (USACE) executes the FUDS Program for the Army. USACE—

*a.* Designs and executes munitions response actions at FUDS under Comprehensive Environmental Response Compensation and Liability Act (CERCLA) and in a manner consistent with applicable federal and state regulations and DOD and Army policy

*b.* Provides property owners and any known tenants written notification of the potential residual explosive or, if applicable, chemical agent hazards present and the potential risks inherent in any use of property in a manner inconsistent with those hazards.

*c.* Maintain an administrative record as required under CERCLA, and permanent records of munitions response actions taken at an MRS.

#### **19–5. General explosives safety principles for munitions responses to munitions and explosives of concern**

Army organizations (such as, IMCOM, USACE) that design or execute munitions responses will conduct munitions responses using the most appropriate technology available with the intent to remove as much MEC as possible consistent with the property’s current, determined, or reasonably anticipated future land use. These organizations also will—

*a.* Ensure close coordination between their explosives safety and environmental organizations.

*b.* Ensure explosives safety personnel (for example, safety specialists, UXO-qualified personnel) are involved in the design, planning and execution of munitions responses to MEC.

*c.* Form an MRS Project Team to use USACE’s Technical Project Planning (TPP) process or the EPA systematic planning process (SPP). The composition of the MRS Project Team will vary based on the complexity of the MRS and the nature of the MEC hazards present. Normally, the Army project manager will lead this team that consists of technical experts, regulatory personnel, and other stakeholder. The MRS Project Team should do the following:

(1) Conduct site-specific evaluations of the potential explosive hazards present. This evaluation will consider available MRS-specific data including, but not limited to the current, determined, or reasonably anticipated future land use, information available from completed response actions (for example, archival research, geophysical and intrusive investigations). In addition:

(2) Develop site-specific data quality objectives (DQOs) required for development of a conceptual site model (CSM).

(3) Assist in planning and determining required munitions response actions (for example, geophysical investigations, removal or remedial actions).

(4) Explain, as required, munitions response and supporting actions (for example, statistical sampling methods used as a basis for the geophysical survey plan and anomaly investigations) to stakeholders.

*d.* Ensure that the process used for designing a munitions response to MEC:

(1) Involves the regulatory community.

(2) Engages stakeholders.

(3) Considers the full range of munitions responses alternatives, including a determination that a response is not required, or a combination of munitions response actions is required.

(4) Considers the current, determined, or reasonably anticipated land use. It should be noted that some areas that the military has used for munitions-related activities may not be appropriate, even after the conduct of munitions response activities, for certain uses (for example, residential development). Such areas include former military range impact areas on which the military has used munitions containing high explosives and sites used for either OB or OD. Such areas may, after a response, be better suited for uses that restrict or limit intrusive activities (for example, wildlife refuges, surface recreational areas).

*(a)* Where unrestricted use is desired, response actions should consider the estimated maximum depth of activities to be conducted, given the land's end use, the maximum penetration depth of any munitions used or munitions-related activities that occurred at the site. Regardless of the robustness of the munition response conducted, it should be realized that some MEC might not be detected or removed. Residual risks can be managed by use of agreed-upon land use controls (LUC), which could include, but would not be limited to safety education; recurring reviews; or construction support.

*(b)* Where intrusive activities will be limited or controlled, the removal depth should equal or exceed the intrusion depth for the type of activity (for example, hiking, camping, construction) for which the property may be used.

*(c)* Where the land use is, or will be, limited to surface activities (for example, wildlife refuge), the munitions response may only involve removing surface MEC. This removal may be technology-aided.

*(d)* Where the current, determined or anticipated land use is compatible with the explosive hazards present or suspected, a removal action may not be necessary.

*(e)* Where a response would adversely impact natural or cultural resources, a removal may not be practical.

*(f)* In some cases, portions of an MRS may be used for different purposes, where this is the case, the design of the munitions response to MEC should be based on current, determined or anticipated land use of each parcel.

*e.* Periodically (for example, during a 5-year review or whatever review interval is consistent with long-term monitoring agreements), review completed munitions response actions to ensure the response remains protective. Periodic reviews should be considered for those MRS where natural phenomena (for example, frost heave, soil erosion, droughts, tidal action) could expose MEC, or where LUC constitute a major element of the response.

## **19-6. Special considerations**

*a.* Prediction of MEC penetration depth—

(1) In certain cases, penetration predictions can be used to supplement geophysical surveys and intrusive investigations of anomalies to estimate the depth of MEC potentially present at an MRS. Penetration predictions can only be used when all of the below conditions are met:

*(a)* The munitions used at the MRS were fire from—

1. Fired from an indirect weapon system (for example, artillery, mortar).

2. Fired from direct fire weapon that was fired into a backstop or a steep hill.

3. Dropped or fired from an aircraft.

*(b)* The projectile impact angle and impact velocity can be reasonably estimated. (Note: If the impact angle and velocity cannot be reasonably estimated, do not attempt to predict a penetration depth or predict penetration by using the theoretical worst-case condition of a 90 degree impact angle and an impact velocity equal to muzzle velocity. These are invalid assumptions that may grossly overestimate the penetration depth.) For indirect-fire munitions, impact angle and velocity are available from firing tables that are available from Commander, U.S. Army TACOM-ARDEC (AMSTA-AR-FSF-10), Aberdeen Proving Ground MD 21005-5001.

(2) Penetration predictions will be based on accepted engineering references (such as, TM 5-855-1) or computer programs derived from such references (for example, Conventional Weapons Effects Program (CONWEP)). (Note: CONWEP is available to U.S. Government agencies from the U.S. Army Waterways Experiment Station, 3909 Halls Ferry Road, Vicksburg, MS 39180-6199).

(3) Penetration prediction must take into account the soil type. (Note: Soil types are available from the garrison or installation Department of Public Works, or for FUDS, from the supporting USACE geographic District.)

(4) Penetration predictions will not be made for direct-fire munitions that were not fired into a backstop, a steep hillside, or from aircraft to ground. If none of the below apply, and a estimated penetration depth is required, assume a depth of 1 ft:

(a) Direct fire, ground-to-ground munitions (for example, 25 mm, 40 mm gun, tank main gun, antitank rocket, and recoilless rifle) that miss the target will impact downrange at shallow angles. If the munition fails to function upon impact, it will ricochet rather than penetrate the ground.

(b) Geophysical and intrusive investigation, rather than penetration predictions, shall be used to estimate the site-specific depth for Army direct fire ground-to-ground munitions whenever possible.

(c) When soil deposition from construction activities or erosion has occurred, the site-specific MEC depth must be determined by geophysical and intrusive investigation alone.

b. *Migration of munitions and explosives of concern.* Naturally occurring phenomenon (for example, erosion, frost heave, tidal actions) may cause subsurface MEC to surface over time. The design of a munitions response, particularly any long-term monitoring plan should consider the potential for migration where such phenomenon is most likely to occur.

c. *Soil presenting explosive hazards (explosive soil).* As a result of some past disposal actions (for example, settling ponds at washout plants, sumps at munitions production or demilitarization facilities), mixtures of high explosives in soil, sand, clay, or other solid media can exist at concentrations such that the mixture itself presents an explosive hazard. Such soil is referred to as “explosive” soil. Explosive soil is not the same thing as “explosives soil”. Explosives soil refers to soil that contains explosives at any concentration that may or may not present an explosive hazard. For QD purposes, the NEW of explosive soil is the weight of the mix times the explosives concentration (for example, 1,000 lbs of soil with 10 percent TNT has an NEW of 100 lbs).

(1) The concentration of a particular high explosive in soil that is necessary to present an explosive hazard depends on whether the particular high explosive is classified as “primary” or “secondary.” Sufficient concentrations of certain propellant constituents (nitrocellulose - NC, nitroglycerine - NG, nitroguanidine - NQ) can also present explosive hazards in soil. These concentrations are based on the test reports listed below that can be requested from the Army Environmental Center (usaectc@aec.apgea.army.mil).

(2) Primary high explosives are those extremely sensitive explosives (or mixtures thereof) that are used in primers, detonators, and blasting caps.

(a) Soil containing 2 percent or more by weight of any primary explosive or mixture of primary explosives can present explosive hazards and will be treated as HD 1.1 material. This determination is based on information provided by USAEC as a result of tests conducted and reported in USAEC Report SFIM-AEC-ET-CR-97015, “Follow-On Reactivity Study of Primary Explosives in Soil,” May 1997”.

(b) Variations in soil type or moisture level can raise the concentration that presents detonation hazards above the 2 percent, which is a conservative default. Reactivity testing may be used to justify higher threshold concentrations at a site. For test protocol, see USAEC Report SFIM-AEC-ET-CR-97015.

(c) Soil containing less than 2 percent by weight of any primary explosive does not present explosive hazards.

(3) Secondary high explosives, which are much less sensitive than primary explosives, are bursting and boosting explosives that are used as the main bursting charge, or as the booster that sets off the main bursting charge. Secondary high explosives are much less likely to react if struck or when exposed to friction or sparks. Generally, explosives that are not more sensitive than RDX are considered secondary explosives. Contact USATCES for sensitivity information.

(a) Soil containing 10 percent or more by weight of any secondary explosive or mixture of secondary explosives will be treated as HD 1.1 material. This determination is based on information provided by the U.S. Army Environmental Center (USAEC) as a result of tests conducted and reported in USAEC Report AMXTH-TE-CR 86096. “Testing to Determine Relationship Between Explosive Contaminated Sludge Components and Reactivity,” January 1987”.

(b) Variations in soil type or moisture level can raise the concentration that presents detonation hazards above 10 percent, which is a conservative default. Reactivity testing may be used to justify higher threshold concentrations at a site. See USAEC Report AMXTH-TE-CR 86096 for test protocol.

(c) Soil containing less than 10 percent by weight of any secondary explosive does not present explosive hazards.

(4) Soil containing propellant constituents (NC, NG, NQ) may also present explosive hazards.

(a) Soil containing 10 percent or more by weight of NC, NG, or NQ will be treated as 1.1 material based on testing reported by SFIM-AEC-ET-CR-97015 (NC) and SFIM-AEC-ET-CR-95083, “Composting of Nitrocellulose Fines - Hazards Analysis”, October 1995 (NC). The 10 percent threshold for NQ is established based on analogy.

(b) Soil containing less than 10 percent by weight of propellant constituents does not present explosives hazards.

d. *Construction support.*

(1) The responsible authority (for example, installation or district commander or a designated representative) will determine whether construction support is required and the level of such support (that is, on-call or on-site) required based on site-specific data. Construction support may be required during the below activities.

(a) Intrusive activities (for example, building construction, dredging, laying utilities, road improvements) on property known or suspected to contain MEC, or on property on which residual explosive hazards may exist.

(b) The removal or the treatment of debris or media in areas where there is a probability of encountering MEC (for example, former OB/OD grounds, legacy “dumps”).

(2) When the responsible authority determines that the probability of encountering MEC is low (for example, the likelihood of encountering MEC is considered possible, but not probable), “on-call” construction support may be provided, on an as-needed basis. A “low” determination may only be assigned to those areas for which a search of available historical records and/or on-site investigation data indicates that, given the military or munitions-related activities that occurred at the site, the likelihood of encountering MEC is low. Munitions-related activities that may merit a “low” determination include, but are not limited to, the former use of the area for live-fire training exclusively with SSA; for maneuver training, to include maneuver training involving the use of smokes, pyrotechnics and simulators; as firing points; for munitions inspection, handling, storage or transfers, to include residue points and inert storage yards; for air defense; or as munitions operating facilities in which the processes used did not result in the generation of concentrations of munitions constituents high enough to present an explosive hazard. Areas on which previous responses have been completed may also qualify for “low” determinations. Discovery of MEC on “low” sites requires immediate reassessment of the level of construction support required. On-call construction support:

- (a) Can respond from offsite when called or be onsite and available to provide required construction support.
- (b) Must be provided by EOD or UXO-qualified personnel who should be available to respond if construction personnel encounter or suspect they have encountered MEC.

(3) When the responsible authority determines that the probability of encountering MEC is Moderate to High (for example, the likelihood of encountering MEC is considered moderately to highly probable), on-site “removal” construction support must be provided by trained and qualified personnel to remove explosive hazards in the construction footprint, per a DDESB-approved Munitions Response Explosives Safety Submission (MRESS), before intrusive construction or other intrusive activities occur. A “moderate to high” determination may be assigned to those areas for which a search of available historical records and/or on-site investigation data indicates that, given the military or munitions-related activities that occurred at the site, there is more than a low probability that MEC is present. Munitions-related activities that may merit a “moderate to high” determination include, but are not limited to the use of an area for live-fire training, other than exclusively with SAA; as a range impact area; for OB or OD of excess, obsolete, or unserviceable munitions; as munitions operating facilities where processes used might have resulted in the generation of concentrations of munitions constituents high enough to present an explosive hazard; or for munitions burial. (Note: When the depth of construction excavation exceeds the detection limits of the detection equipment used, soil will be removed in layers to allow detection and removal of MEC in the construction footprint.)

*e. Anomaly avoidance.*

(1) Anomaly avoidance techniques may be employed on properties known or suspected to contain MEC to avoid contact with potential surface or subsurface MEC to allow entry to an area for the performance of required operations (for example, cultural resource studies, installation of environmental monitoring wells).

(2) During anomaly avoidance:

(a) Surface MEC will be avoided, with the location of any MEC encountered noted and reported to appropriate authorities.

(b) Subsurface anomalies will be avoided, with any detected anomalies marked, when appropriate.

(c) Support must be provided by EOD personnel, or UXO-qualified personnel or UXO technicians. (Note: In areas known or suspected to contain CWM, such support can only be provided by EOD or UXO-qualified personnel trained in CWM responses.)

*f. Material presenting a potential explosive hazard* Manage MPPEH in accordance with DOD 4140.62 pending publication of Army implementing guidance.

## **19–7. Real property (buildings and installed equipment)**

*a. General.*

(1) The AE operating and former operating buildings (for example, munitions production or demilitarization facilities) and any installed equipment may contain residual explosives that present an explosive hazard. Of particular concern are building features (such as, floors, roofs, walls, drains, internal and external piping, ventilation systems) in which explosives residues could present explosive hazards and industrial equipment, particularly equipment with internal cavities from facilities used in munitions production or demilitarization operations (for example, cast loading or milling, steam-out) that generated explosives residues (such as, dust, vapors, liquids).

(2) Because such facilities were to remain under DOD control and be retained as part of DOD’s industrial base, the procedures used for cleaning AE operating buildings only partially removed residual explosives from the buildings and installed equipment. Prior to inactivating a building, explosives workers would wash down the exterior of any installed equipment, walls, and floors; and flush piping and vessels used to process explosives. Because these procedures did not remove all residual explosive residues for example, residues that may have filled voids in walls, or equipment), the remaining explosive residues potentially pose explosive hazards. As a result, installations normally classified deactivated AE operating buildings and installed equipment as “3X.” “3X” indicated residual explosives that potentially present explosive hazards may remain present. Some of installations on which these buildings exist have been affected by BRAC decisions or have been determined excess to DOD requirements. As a result, some of these buildings are

now being demolished or transferred from DOD control. The below procedures provide guidance for addressing buildings and equipment that may contain explosives hazards. (See also DODI 4140.62.)

(3) Test data addressing the concentration (for example, grams per square centimeter) of residual explosives on a surface that would present an explosives hazard is very limited. Neither DOD nor Army have approved surface-concentration thresholds for explosivity or reactivity. Therefore, the best way to conservatively determine whether a given surface presents potential explosives hazards is through visual inspection or field colorimetric screening tests. When such tests show that explosives residues are present, further evaluation and analysis is required.

(4) See paragraphs 19–7*b-d* (below) provides steps for classifying buildings as to their extent of any explosives residue present, inspecting and testing buildings for explosives residues; and removing explosives residues to eliminate any explosives hazards. Personnel responsible for determining whether explosives hazards may be present in an AE-operating building should review historical records about and consult with people who know the specific explosives AE-related operations that were conducted in a particular building. Although this guidance is conservative (it may classify some explosives residues as potentially posing an explosives hazard when such residues may not do so), it correctly classifies many instances where trace amounts of explosives may exist, but do not present explosives hazards. Such trace residuals, may, however, qualify, from an environmental perspective, as hazardous waste.

*b. Step One: Classify the Likely Extent of Any Explosives Residues Present.* Depending on the type of AE operating building and/or the AE-related operations conducted, classify the explosives residues in the building and its installed equipment as either “limited” or “significant.”

(1) “Limited” explosives residues are normally the result of a minor release of explosives in the immediate operating area with little to no migration. Operations that—

(a) Do not involve exposed explosives produce little, if any, explosives residues.

(b) Involve only exposed explosives and where mass high speed handling does not occur generally produce only a limited amount of explosive residues.

(c) “Significant” explosives residues are normally the result of operations (for example, milling, cutting, steaming out) that involve working with open explosives. Such operations release explosives as solid (for example, dust), liquid (for example, pink water), or vapor (for example, steam). These forms of explosive residues can migrate into inaccessible areas (for example, cracks, voids, behind wall and roof panels, drains, roof rafters, porous surfaces) and other areas. Such AE-related operation can result in extensive migration of significant amounts of explosives residues in a building and its installed equipment. In general, any operation capable of generating the release of significant quantities of explosives solids, liquids, or vapors must be assumed to produce significant explosives residues.

(d) Operations capable of generating explosives dusts may result in the presence and migration of significant explosives residues. Generally, any operation that involves high speed, mass handling of exposed solid explosives will produce explosives dusts. Dust from such operations can migrate and settle onto accessible surfaces and behind hidden surfaces. Additionally, daily equipment washdowns can carry a significant amount of these explosives residues into waste streams and systems. In contrast, AE-related operations that generate explosives chunks, slabs, or other large pieces of explosives residue generally would not result in the presence or migration of significant amounts of explosive residues, but such operations could allow for migration of explosive residues into wastewater drains and sumps.

(e) In-process liquid explosives (for example, melted trinitrotoluene (TNT)) can result in the presence of significant amounts of explosives residues inside all pipes and vessels that carry these liquid explosives. Steam from these processes can result in a significant amount of explosive residues building up in a number of areas (for example, on tops of structural ceiling beams, ventilation systems, sills). Additionally, spills and periodic (for example, daily, weekly) wash-downs of equipment can carry dissolved or suspended explosives residues into cracks in the floors, drains and sumps. These processes can also result in soil near the building becoming contaminated with high-concentrations of explosives. For purposes of assessment, liquid explosives includes explosives that are:

1. In a liquid state at normal temperatures (for example, nitroglycerin);

2. Heated and melted for further processing (for example, melting TNT for loading into projectiles or blending with other explosives).

3. Dissolved in a solvent.

4. Suspended in a liquid carrier.

5. Colloided—limited to in-process propellants in liquid or paste (for example, a colloided state) that have not yet been dried to a solid colloid.

(f) Gases. Generally, whenever an explosive that is a solid at normal temperatures is heated into a liquid (melted), some of the melted explosive volatilizes into the air. This gaseous explosive can migrate about the building and condense on any surface it comes in contact with, including hidden surfaces. After condensation, the explosive is again a solid.

(2) Figure 19–1 provides examples of explosives operations/buildings and classifies each example as to:

(a) The phase (solid, liquid, gas) of the explosives residue(s) released when the process was in operation and

(b) The extent of explosives residues (significant or limited).



Type of AE Operation or Facility	Phase of Explosive Released (Solid, Liquid, Gas)	Extent of Explosives Residues Present	
		Significant	Limited
1. Amatol manufacture	Solid (spills of explosive in the cooling/pelletizing/flaking area)		X
	Liquids (washdown water, spills of melted explosive)	X	
	Gas (from melted TNT) (see note 3)	X	
2. Ammonium nitrate manufacture	Solids (generated during handling and packing of dried crystals)		X
	Liquids (vessels/piping/evaporators/prilling towers used in actual manufacture, which involves ammonium nitrate in solution in water; washdown water; wastewater)	X	
3. Booster pellet pressing, high speed, high volume, automated	Solids (dusts)	X	
	Liquids (washdown water)	X	
4. Bullet impact testing	Solids (chunks)		X
5. Cast loading	Solid (dust particles generated during crushing of sprues for remelting, or tamping pelletized explosive onto top of casting)	X	
	Liquids (washdown water, spills of melted explosive)	X	
	Gas (from melted explosive)	X	
6. Change houses <sup>1</sup>	Solid		X
7. Chipping	See pelletizing		
8. Closing plug installation or removal	Solid		X
9. Composition B manufacture	Solid (spills of explosive in the cooling/pelletizing/flaking area)		X
	Liquids (washdown water, spills of melted explosive)	X	
	Gas (from melted TNT) (see note 3)	X	
10. Contained detonation chamber	Solid (small amounts of undetonated explosive)		X
11. Contaminated waste processing (a type of thermal treatment)	Solid (unburned explosive; presence of more than trace amounts unlikely)		X
12. Cutting, high speed, high volume	Solid (small chunks not caught by coolant)		X
	Liquid (washwater, coolant recovery/reconditioning system)	X	
13. Cyclotol manufacture	Solid (spills of explosive in the cooling/pelletizing/flaking area)		X
	Liquids (washdown water, spills of melted explosive)	X	
	Gas (from melted TNT) (see Note 3)	X	
14. Depriming cartridge cases, press fit primers, high speed, high volume, automated	Solid (dusts)	X	

Figure 19-1. Phase and extent of explosives residues

15. Depriming cartridge cases, press fit primers, low speed, low volume, automated or manual	Solid (loose primers, small particles)		X
16. Depriming cartridge cases, threaded primers	Solid (small particles)		X
17. Detonator press loading, high speed, high volume, automated	Solid (dusts)	X	
	Liquid (washdown water)	X	
18. Drilling explosives, low speed, automated, not liquid cooled	Solid (small particles)		X
	Liquid (washdown water)		X
19. Drilling explosives, liquid cooled	Solid (small chunks not caught by coolant)		X
	Liquid (coolant recovery/reconditioning system, washdown water)	X	
20. Explosive D manufacture	Liquid (in picric acid/ammonia reaction vessels and piping; spills; wash-down water; wastewater)	X	
21. Explosive waste incineration (a type of thermal treatment)	Solid (residual unburned explosive)		X
22. Explosives or explosives dust vacuum collection	Solid (dusts)	X	
23. Extrusion, propellant grains and demolition charges, high speed, high volume	Solid (chunks and particles)		X
	Liquid (washdown water)	X	
24. Firing hardstands for missiles, guns, etc.	Solid (small particulates)		X
25. First fire composition manufacture	See pyrotechnic mixing		
26. Flaking	See pelletizing		
27. Flare mix manufacture	See pyrotechnic mixing		
28. Flashing (a type of thermal treatment)	Solid (unburned explosive)		X
29. Fuze installation or removal	Solid (release of explosives very unlikely)		X
30. Fuze liner removal	Solid (chunks of explosive adhere to fuze liner exterior and can fall off on floor)		X
31. Gaging ammunition	Solid (release of explosive very unlikely)		X
32. HBX manufacture	Liquids (washdown water, spills of melted explosive)	X	
	Gas (from melted TNT) (see Note 3)	X	
33. HMX manufacture	Liquid (HMX is dissolved in solvents at certain stages of manufacture)	X	
34. Hot gas decontamination	Solid (small particles of explosive that fell off the items to be treated may remain in the hot gas chamber)		X
35. Ignition mix manufacture	See pyrotechnic mixing		
36. Incendiary mix manufacture	See pyrotechnic mixing		

Figure 19–1. Phase and extent of explosives residues—continued

37. Incineration	Solid (small amounts of unburned explosive may remain in the incinerator)		X
38. Inspection (e.g., surveillance workshops, "K" lines)	Solid (small amounts of explosive may have been spilled during inspection)		X
39. Lathe turning, low speed, not liquid cooled	Solid (dusts, small chunks)		X
	Liquid (wash-down water)	X	
40. Lathe turning, liquid cooled	Solid (small particles that are not captured by coolant)		X
	Liquid (wash-down water, coolant recovery/reconditioning system)	X	
41. Laundering facilities for explosives workers' coveralls <sup>2</sup>	Solid (small particles dropped from clothing prior to washing)		X
	Liquid (laundry washwater)		X
42. LCL (less than car-load) building	Solid (minor spills)		X
43. Lifting plug installation or removal	Solid (very small particulates at most)		X
44. Linking or de-linking ammunition	Solid (release of any explosive not likely)		X
45. Loading dock	Solid (small possibility of minor spills due to accidentally punctured containers of ammunition or bulk explosives)		X
46. LTL (less than truck load) Building	Solid (minor spills)		X
47. Melt out of explosives from projectiles or bombs	Solid (spills of explosive in the cooling/ pelletizing/flaking area)		X
	Liquids (washdown water, spills of melted explosive)	X	
	Gas (from melted explosive)	X	
48. Melt-pour of explosives into projectiles, warheads, bombs, etc	See Cast loading		
Milling	See Drilling		
49. Missile final assembly/disassembly (does not include assembly/disassembly of explosives components)	Solid		X
50. Missile maintenance	Solid		X
51. Nitrocellulose manufacture	Liquid (in nitrating vessels, in wringers and dryers, equipment wash-down water, wastewater)	X	
52. Nitroglycerine manufacture	Liquid (in nitrating vessels, separators, washers, settling tanks, nitroglycerin storage tanks, equipment wash-down water, wastewater)	X	
53. Octol manufacture	Solid (spills of explosive in the cooling/ pelletizing/flaking area)		X
	Liquids (washdown Water)	X	
	Gas (from melted explosive)	X	
54. Pack/unpack bay in a	Solids		X

Figure 19-1. Phase and extent of explosives residues—continued

maintenance or production building			
55. Packaging and shipping	Solids		X
56. Painting or marking ammunition or packaging	Solids (no release likely)		X
57. Palletizing	Solids (no release likely)		X
58. Pelletizing	Solids		X
	Liquids (washdown water, spills from melted explosive)		X
	Gas (from melted explosive)	X	
59. Personnel shelters	Solids (no release likely)		X
60. Photoflash powder manufacture	See Pyrotechnic Mixing		
62. Popping Plant (a type of thermal treatment)	Solid (unburned explosive)		X
63. Pressing, low speed, automated or manual (normally used in the press loading larger items, such as projectiles and warheads)	Solid		X
64. Pressing, high speed, high volume, automated (normally used in the pressing of smaller items, such as detonators and small shaped charges)	Solid (dusts)	X	
	Liquid (washdown water)	X	
65. Primer loading, high speed, high volume, automated	Solid (dusts)	X	
	Liquid (washdown water)	X	
66. Primer mix manufacture	See Pyrotechnics	X	
Priming cartridge cases	Solid		X
67. Projectile base plate assembly or removal	Solid		X
68. Projectile crimping	Solid		X
69. Projectile fin assembly or removal	Solid		X
70. Projectile main charge pressing	Solid		X
71. Projectile ogive assembly or removal	Solid		X
72. Projectile pull-apart (from cartridge case)	Solid		X
73. Projectile rotating band or obturator assembly or removal	Solid		X
74. Projectile seating	Solid		X
75. Projectile tracer assembly to bullet, tracer element has no metal body (typical for small caliber ammunition [.50 cal and smaller])	Solid (dusts)	X	
76. Projectile tracer - assembly to or removal from projectiles and tracer elements have metal bodies (typical for medium and large caliber [20mm and larger])	Solid (small particles)		X
77. Propellant collection, in containers, high speed, high volume	Solid (dusts) (normally captured in a vacuum collection system)	X	

Figure 19–1. Phase and extent of explosives residues—continued

	Liquid (in washdown water)	X	
78. Propellant collection, in containers, low speed (usually manually dumped), low speed, low volume	Solid (individual grains of propellant)		X
79. Propellant collection, using vacuum collection system	Solid (dusts)	X	
80. Propellant loading or removal, bagged propellant	Solid (individual grains)		X
81. Propellant loading or removal, unbagged (loose) propellant, high speed, high volume	Solid (dusts) (normally captured in a vacuum collection system)	X	
	Liquid (washdown water)	X	
82. Propellant loading or removal, unbagged (loose) propellant, low speed, low volume	Solid (individual grains)		X
83. Propellant manufacture – single, double, or triple base	Solid (small chunks released at extrusion and cutting operations)		X
	Liquid (solvent/propellant mixing equipment, waste water, equipment wash-down water, nitroglycerin tankage and supply lines [double and triple base only])	X	
84. Propellant or propellant dust vacuum collection	Solid (dusts)	X	
85. Pyrotechnic ingredient mixing, dry	Solid (dusts)	X	
	Liquid (wash-downs)	X	
86. Pyrotechnic ingredient mixing, wet	Liquid (in mixing vessels and associated piping, from spills during wet mixing, from wash-downs)	X	
87. RDX manufacture	Solid (in drying rooms or equipment)	X	
	Liquid (in nitration vessels and piping, from spills, wash-down water, wastewater)	X	
88. Rotary kiln furnace (a type of thermal treatment)	Solid		X
89. Shaker testing	Solid		X
90. Signal mix manufacture	See Pyrotechnics		
91. Starter mix manufacture	See Pyrotechnics		
92. Static test stand for warheads, projectiles, etc	Solid		X
93. Steam out of explosives from projectiles or bombs	See Melt Out	X	
94. Storage (e.g., earth-covered magazines, aboveground magazines, covered storage pads, service magazines)	Solid (low possibility of traces of spilled explosives)		X
95. Supplementary charge insertion or removal	Solid (small particles)		X
96. Temperature conditioning units or magazines	Solid		X
97. Temporary storage bay in a maintenance or production building	Solid		X
98. Tetryl manufacture	Solid (in drying rooms or equipment)		X

Figure 19–1. Phase and extent of explosives residues—continued

	Liquid (inside all reaction vessels and piping serving them; from washdown water and process waste water)	X	
99. Tetrytol manufacture	Solids (in drying rooms or equipment)		X
	Liquids (washdown water, spills of melted explosive)	X	
	Gas (from melted TNT and tetryl)	X	
100. TNT manufacture	Solid (flaking operation)		X
	Liquid (nitrating vessels and associated piping, molten TNT purification vessels, washdown water, waste water)	X	
	Gas (explosive effluent tetranitromethane emitted at trinitration step; TNT vapors from molten TNT purification vapors)	X	
102. Torpex manufacture	Liquids (washdown water, spills of melted explosive)	X	
	Gas (from melted TNT) (see Note 3)	X	
103. Tracer mix manufacture	See Pyrotechnics		
104. Tritonal manufacture	Liquids (washdown water, spills of melted explosive)	X	
	Gas (from melted TNT) (see Note 3)	X	
105. Vacuum collection system for propellant or explosives	See Propellant Vacuum Collection		
106. Vibration testing			X
107. Wash out of explosives from projectiles or bombs	See Melt-out		

Figure 19–1. Phase and extent of explosives residues—continued

*c. Step Two: Inspect and test for explosives residues.* Visual inspection, supplemented by colorimetric tests, can conservatively determine the presence of explosives hazards. The underlying principle in the rules below is that explosives residues undetectable to the human eye pose no explosives hazards.

(1) *General rules.*

(a) All surfaces where explosives residues are suspected to have been deposited must be visually inspected. The number of surfaces visually inspected depends on the type of AE-related activities that occurred in a building and the potential for explosives residues to be present (see para 19–7b). If an area (for example, voids in walls or equipment, cracks in flooring) where significant explosives residue might be expected to be present cannot be visually inspected, assume that an explosives hazard may be present.

(b) If explosives can be seen on a surface, assume a potential explosive hazard.

(c) If explosives or other suspect residues cannot be seen on a nonporous surface it is unlikely that a potential explosives hazard exists, even if a colorimetric test yields a positive reaction. (See para 19–7c(3)(d) for porous surfaces.)

(d) If unidentifiable foreign material can be seen on a surface, perform either a colorimetric field test or a flame test. For a colorimetric field test, there are readily available commercial colorimetric test kits (for example, EXPRAY) that are widely used. These commercially available field tests can detect a wide range of explosives compounds. If a test is positive, assume a potential explosives hazard. However, some commercially available field tests detect extremely small amounts of explosive; therefore, may potentially provide an overly conservative “positive” reading. If acceptance of a potential explosive hazard is not reasonable for a given location, perform a flame test. For a flame test, it is permissible to test a small sample of unidentifiable material for its reaction to flame. Using non-sparking tools, collect a sample of the material no larger than a pinhead. Locate the sample in an area away from any areas known or suspected to contain explosives. Place the sample on a clean, dry, nonflammable surface, such as a steel plate. Although the test quantity is so small it will not expose test personnel to explosive hazards, leather gloves, full face protection, and ear protection are required. The operator will expose the sample to flame, such as a portable blowtorch. It is best to perform this test at least 10 times. An energetic reaction (rapid burning or a “pop”) during any test indicates that a potential explosives hazard exists.

(2) For AE facilities or equipment that may contain only “limited” explosives residues visually inspect or test accessible surfaces using procedures provided in paragraph 19–7c(1). It is not necessary to visually inspect inaccessible surfaces, as explosives migration into these areas is very unlikely.

(3) For AE facilities or equipment that may contain "significant" explosives residues:

(a) *Surfaces.* Visually inspect or test accessible surfaces using procedures provided in paragraph 19–7c(1). Inaccessible surfaces should be accessed for inspection or test by disassembly. Care must be taken when disassembling equipment known or suspected to contain explosives residues. All threaded connections, flanges, mating surfaces and any similar connections should be soaked with penetrating oil and allowed to sit for 24 hours before disassembly. Pipes and tanks with known or suspected explosives residues should be filled with water before disassembly. Disassembly can be performed manually, or with remotely controlled power equipment. The risks associated with manual disassembly are greater than those posed by remote disassembly. During manual disassembly, do not use chisels, saws, or drills; do not loosen threaded connections by using cheater bars on wrenches; do not pound equipment with hammers; and do not hammer wedges into mating surfaces to separate them. The use of power tools (such as, saws, shaped charges, shears, and so forth) during disassembly must be done remotely when either explosive residues are known to be present or the absence of explosives cannot be verified. Inaccessible surfaces (for example, voids in walls, the interior of piping) that cannot be disassembled can sometimes be inspected by specialized equipment (for example, borescope). However, use of such equipment may not allow a determination of whether a surface is merely discolored or there is explosive or other residue on the surface. Therefore, if foreign material is seen, assume it presents potential explosives hazards, unless a sample can be remotely collected for colorimetric or flame test. Inaccessible surfaces that are not disassembled or remotely inspected or tested shall be considered to contain explosives residues that present potential explosives hazards. For many AE operating buildings in which operations occurred that would likely result in the presence of significant explosives residues, it is often more effective to simply assume any inaccessible surfaces contain explosives residues. When this is the case, and the building is to be demolished, it may be appropriate to burn the building (see para 19–7d).

(b) *Cracks.* Cracks may hide explosives residues. Cracks often occur in welds or joints, but can occur in other areas as well. Experience has shown the amount of secondary explosive residue in cracks is insufficient to create a hazard where the outside surfaces are confirmed clean, the material is nonporous, and the material is no more than 1/8-inch thick. Assume all nonporous materials over 1/8-inch thick have cracks, unless a detailed visual inspection proves otherwise. Assume all cracks containing primary explosives present a potential explosive hazard regardless of the thickness of the material.

(c) *Porous surfaces.* Porous materials (for example, unpainted wood, flooring that is not sealed, gypsum board, cardboard) may absorb explosives residues that are in a liquid or vapor form. These explosives may be undetectable during a visual inspection. If AE-related operations that occurred in a building indicate that liquid or vapor explosives may have been released and the building contains porous surfaces, assume explosives residues have penetrated the porous material surface and physical cleaning would not have decontaminated the material. (See table 19–1.)

**Table 19–1**  
**Absorption of explosives as a function of type of material and phase of explosive**

Type of material <sup>1</sup>	Phase of explosive		
	Solid <sup>2</sup>	Liquid <sup>3</sup>	Vapor <sup>4</sup>
Painted wood	Non-absorptive	Non-absorptive	Non-absorptive
Unpainted wood	Non-absorptive	Absorptive	Absorptive <sup>6</sup>
Metal (except cast iron)	Non-absorptive	Non-absorptive <sup>8</sup>	Non-absorptive
Cast iron	Non-absorptive	Non-absorptive <sup>7</sup>	Non-absorptive <sup>7</sup>
Concrete	Non-absorptive	Non-absorptive <sup>7</sup>	Non-absorptive <sup>7</sup>

**Table 19-1**  
**Absorption of explosives as a function of type of material and phase of explosive—Continued**

Transite	NA <sup>5</sup>	NA <sup>5</sup>	Non-absorptive
----------	-----------------	-----------------	----------------

Notes:

<sup>1</sup> Assumes material contains no cracks. Cracks are addressed in paragraph 19-7c(3)(c).

<sup>2</sup> Includes not only chunks, slabs, and so forth, but also explosives dust. Explosives dusts are not vapors. Dusts are composed of individual particles of explosive in the air. Each particle consists of many (millions) of molecules of the explosive. Vapors consist of individual molecules of the explosive in the gaseous state.

<sup>3</sup> Includes explosives that are liquids at normal temperatures (for example, nitroglycerine), explosive that are liquids at elevated temperatures (for example TNT, white phosphorous), and explosives that are dissolved in solvents (for example, flare mix dissolved in hexane during a mixing operation), explosives that are suspended in liquids (explosive laden waste or wash water), and propellant colloids before the colloid is dried.

<sup>4</sup> Vapor phase explosives are found where explosives are melted to pour them into shell or bomb bodies. They are also found where explosives are washed, steamed, or melted out of shell or bomb bodies.

<sup>5</sup> Transite, an extremely fire-resistant material, was used for roof shingles and sometimes for the exterior siding of ammunition and explosives buildings. Solid or liquid explosives contact with transite is therefore an unlikely scenario.

<sup>6</sup> Of particular concern is wood in proximity to any explosives manufacturing operation involving nitration or nitric acid. This wood can itself become partially nitrated so as to form low-grade cellulose nitrate, a flammable solid.

<sup>7</sup> Small amounts of liquid or vapor explosive can migrate into concrete and case iron, but not in sufficient quantities to present explosion hazards.

<sup>8</sup> Explosives can reside below the rust and scale inside of pipes and tanks.

(d) Drains, waste disposal systems, and slabs. The drains and waste disposal systems (for example, industrial and sanitary sewers, sumps) directly associated with AE-operating buildings in which operations occurred that would likely result in the presence of significant explosive residues must also be assumed to present a potential explosives hazards. Concrete slabs and any soil underneath the slab may also contain significant amounts of explosives residues deposited through cracks or other openings as a result of operations conducted within the building or from cleaning the building or equipment. Explosive may also have built up in the soil surrounding a building.

*d. Step 3: Remove Explosives Residues.*

(1) In AE facilities or equipment that may contain only "limited" explosives residues, any explosives residues present would not be expected to migrate into hidden surfaces and would most likely be readily detected during a visual inspection of all accessible areas. Any explosives, including munitions or munitions components, found should be manually removed. After visual inspection and removal of any residual explosives, such buildings and any installed equipment can be considered to present no explosives hazards.

(2) For AE facilities or equipment that may contain "significant" explosives residues:

(a) Traditionally, burning AE buildings in place has been the method used to remove explosive hazards from explosively contaminated buildings and installed equipment. A normal procedure is to burn the building or heat the building and its installed equipment to a level above the decomposition temperature of explosives residues and hold the temperature long enough to ensure the largest mass of the building is at that temperature; thereby, decomposing any explosive residues present. Combustible material (for example, wooden pallets, hay bales) may be added to the buildings to provide the required temperature. Enough combustible material must be added to bring the building and equipment up to and over the temperature at which explosives will decompose, burn, or detonate. Explosives will decompose, burn, or detonate when exposed to temperatures of 600 degrees Fahrenheit, which is conservative as any explosives will decompose at lower temperatures, for a sustained period. Experience shows that a sustained, vigorous engulfing burn for at least one hour ensures all building features, including equipment, reaches this temperature. If specific data is available to support a lower temperature, then the lower temperature may be used. It should be noted that measuring the burn temperature is an important aspect of the explosive decontamination process. Extensive temperature monitoring of the first buildings burned at a site provides data to indicate the amount of combustible material necessary for subsequent burns in other buildings.

(b) Detonations that may occur during a burn may expel equipment or other material (for example, piping) that will require inspection and may require re-flashing. To reduce the number of detonations that may occur during a burn, vent any explosives-laden vessels, piping or equipment (for example, motors, dust collectors) that may be capable of containing pressures and detonating to minimize the probability of accidental detonation during a burn. Linear shaped charges are often used to vent material (pipes, equipment) where pressure can build and cause a detonation. When using linear shaped charges, the minimum separation distance (MSD) for all personnel shall be the greater of:

1. K328, which will be based on the sum of the shaped charges' NEW and an estimate of the NEW of any explosives residues in the material being vented;

2. K328, which will be based on only the sum of the shaped charges' NEW when a prior inspection determined that the shape charge can be positioned over an area where explosives have not accumulated; or

3. 1,250 ft. If explosives (for example, linear shaped charges) cannot be used for any reason (such as, noise concerns), remotely operated saws or water jet cutters can be used. In these cases, all personnel shall withdraw to the greater of K50 or 1,250 ft.

(c) An MCE, which establishes the MSD for all personnel during the demolition (for example, burning) of a



building or AE process equipment, will be based on an estimate of the NEW involved. This estimate should be made during step one. The MSD shall be the greater of K328, which is based on the MCE, or 1,250 ft. Although many explosives will merely burn when a building is burned, some explosives residues, particularly those located in confined locations (for example, process vessels, piping), may detonate.

(d) After a burn, the burn's effectiveness should be verified. It should be noted that burning a building in place will not necessarily remove any explosives accumulation that has occurred beneath slabs (see 19-7d(2)(j) and (k)). The primary method for monitoring and verifying that a burn has removed explosive hazards from a building and any installed equipment is to confirm that the temperature at which explosives decompose, burn, or detonate was achieved. Temperature verification (see paras (e) to (g), below) may be conducted using several different methods either alone or in combination.

(e) Real-time temperature monitoring, which is the only method that measures both temperature and time, positively confirms that a temperature of "600 degrees for one hour" was attained. Using this method, thermocouples are placed at select locations within the buildings and equipment during setup for the burn. Thermocouples should be placed in areas of a building that are of greatest concern (and that are also most insulated by surrounding equipment or building structural features) to document that the required temperature is maintained for the required amount of time. Data loggers (such as multi-measurement System MMS-3000-T6V4) and thermocouples provide continuous real-time monitoring of a burn. Thermocouple wires must be protected from heat as they will degrade at the burn temperatures. The data logger must be placed outside of the building in a location protected from the heat.

(f) Certipaks can also be used to verify that any explosive hazards have been removed. Certipaks can be prepared by dissolving two grams of the type of explosives present at the site in 10 mL of acetone. When necessary, the explosive may be recovered from the site. Porcelain boiling beads or chips are immersed in the solution and allowed to sit for ten minutes. These chips are then removed and allowed to air dry on a square of aluminum foil. Once dry, six of the beads or chips are randomly selected for testing for the presence of detectable levels of explosives using a commercially available colorimetric test kit. Upon confirmation that the explosives can be detected, 3 to 5 beads or chips are wrapped in aluminum foil or stainless steel or galvanized sheet steel and placed in clean one-quart paint cans for placement in and around the building and equipment that are to be burned. Following the burn, any of the certipaks (paint cans) that are intact cans are recovered, with the recovered beads tested for the presence of explosives. Because it takes a temperature of approximately 900 degrees to melt a paint can, it is unnecessary to attempt to recover and test the beads or chips that were placed in the melted cans.

(g) Other methods that only measure the maximum temperature achieved can be used to verify a burn's effectiveness. When used, the target temperature must be raised to 900 degrees F, which is the "fast reaction" temperature for all explosives. This ensures that any explosives reaching this temperature even if only for a few seconds will react. Temperature sensitive crayons, (for example, OMEGASTICK®), pellets (for example, OMEGAPELLET®) or lacquers (for example, OMEGALAQ®) that have a target change temperature of 900°F should be placed inside piping and equipment at several locations throughout the building being burned. These crayons and pellets melt at the target temperature. The melting and resolidification in a new shape or disappearance is proof that the melting point was reached. Lacquers, when initially applied; dry to a dull opaque mark. When the target temperature is reached, the material melts and upon cooling solidifies to a glossy-transparent appearance. If a temperature significantly above the target is achieved or the target temperature is held for an extended period, the paint may char.

(h) Post-burn inspection and testing can be performed as a final check. UXO-qualified personnel can inspect and test selected surfaces using a commercially available colorimetric test kit (for example, Expray®). Selection of the areas tested is based on judgment of UXO-qualified and on-site personnel.

(i) An alternative to burning or heating a building and its installed equipment is to use engineered disassembly and explosives removal. Disassembly operations are far more extensive than the disassembly and venting operations required prior to a burn. When installed equipment must be manually disassembled for inspection and decontamination, the procedures described in paragraphs 19-7c(3)(b), 19-7d(2)(b), and 19-7d(2)(c) apply. It is recommended that components of a building and any installed equipment be reduced sufficiently in size to allow thermal treatment in conventional hazardous waste incinerators, heating ovens, or in hot gas decontamination units. At some sites, regulators have permitted the open-air burning of disassociated equipment. In lieu of thermal treatment, conventional cleaning (for example, pressure washing, steam cleaning, brushing, scraping) or chemical neutralization may be employed. Once any contaminated equipment is addressed, the building itself must be addressed. Inspect all building surfaces for explosives, and remove as much explosives as possible from walls, ceilings, rafters by steam cleaning or other approved methods. Walls need to be inspected for penetrations, hollow block construction, openings and cracks and crevices that may contain explosive residues. Noticeable cracks in hollow walls will be flooded with water within three feet on either side of a cracked area. Alternatively, explosives accumulated in hollow walls can be vented by using donor charges. Conventional demolition equipment can then be used to raze the building. If any doubt remains as to whether explosive hazards may be present, "wet" demolition, wherein a stream or mist of water is directed at the portion of the building or equipment being razed, should be used.

(j) Regardless of whether the building is burned in place or disassembled and cleaned, building slabs must still be addressed (burning in place will not effectively remove explosives from slab cracks or beneath slabs). Large amounts

of explosives can accumulate beneath building slabs under certain conditions. If equipment with significant contamination was subjected to periodic washdowns when the equipment was operational, explosive-laden wash water can migrate through cracks in the slab and accumulate beneath it. The burning in place procedures described above will not necessarily remove these explosives accumulations. There are two alternatives to address slabs, depending upon whether the explosives are of the “primary” or “secondary” variety.

(k) Slabs over primary explosives. Primary explosives are initiating explosives used in primers and detonators. Common primary explosives, which are highly sensitive, are lead azide, lead styphnate, mercury fulminate, and DDNP. Dry, undecomposed nitrocellulose, and nitroglycerin, although not technically primary explosives, should be considered as such for this paragraph. Attempt to confirm whether primary explosives may be present under a slab by taking a sample by remotely drilling through the slab into the soil beneath the slab. The building’s usage and classification, the slab’s configuration and the soil’s geology will help determine the number of sample required and locations for drilling for samples. During drilling, maintain IBD. Prior to taking samples, fill the drill holes with water to desensitize sample material and then take samples for field test or laboratory analysis. If the results of sampling are positive or if primary explosives are suspected to be present, do not lift the slabs. The only safe option for removing any primary explosives present is to detonate large linear shaped charges placed over the cracks to detonate any of the primary explosives present. Maintain a minimum withdrawal distance of 2,500 feet during detonation. The slab can then be lifted using hardened equipment. If it is more cost effective, the drilling and lab analysis step can be skipped, and the project can proceed directly to the use of linear shaped charges. If the results are confirmed negative, the slabs can be lifted using conventional equipment (for example, backhoes).

(l) Slabs over secondary explosives. Slabs that are over secondary explosives (for example, TNT; Compositions A, B, and C; Explosive D; octol; and so on), which are less sensitive than primary explosives, may be lifted. Because pinch points may be created at existing cracks when a slab is lifted, thoroughly soak all cracks with water or better yet, oil before lifting.

*Note.* (Nitroguanidine, although not technically a secondary explosive, should be considered such for the purpose of this paragraph.)

*e. Management of building and equipment debris after the removal.*

(1) Because AE operating buildings and equipment that would only contain “limited” amounts of explosives residues generally remain intact after all residual explosives are removed, there is little, if any, building or equipment debris generated. The exceptions are buildings razed because of structural weaknesses that pose safety hazards. Buildings and equipment and any debris to be transferred within or released from DOD control should be processed per DOD 4140.62 until Army implementing guidance is published.

(2) Because AE operating buildings and equipment that contain “significant” amounts of explosives residues are normally damaged or destroyed when residual explosives are removed, significant amounts of building and equipment debris are generated. Buildings and equipment and any debris to be transferred within or released from DOD control, including being placed in a land fill, should be processed per DOD 4140.62 until Army implementing guidance is published.

## **19–8. Submunitions with an high explosive fill**

Many submunitions have very sensitive fuzes. When HE-filled and present as UXO, these submunitions increase the probability of an accidental detonation upon physical contact. The precautions outlined below do not apply to areas used exclusively for live-fire training or testing with practice, incendiary, or other submunitions that lack an HE filler.

*a.* Strictly control access to areas known or suspected to contain submunitions. Brief all personnel entering such areas on the types of submunitions known or suspected to be present. As determined by range managers or munitions response safety personnel, provide UXO escort service for personnel entering any area known or suspected to contain submunitions.

*b.* Prior the conduct of range clearance activities, surface removals or any ground disturbing or intrusive activities (for example, environmental sampling, emplacing utilities) in an areas known or suspected to contain submunitions, complete a CORA per DA Pam 385–30. The CORA shall consider:

(1) *Hazard severity.* The probable result of an accidental detonation of a submunition when in close proximity to an unprotected operator is death or serious injury. When submunitions are being removed from soil using mechanical sifters or other mechanized process and then subsequently shredded, and operators are properly protected by shielding or distance, the probable result of an accidental detonation is negligible (for example, first aid, minor damage to the equipment).

(2) *Hazard probability.* Assess hazard probability based on these factors, at a minimum:

(a) *Fuzing.* Some submunitions’ fuzing systems are more sensitive than others. Submunition fuzes with external firing pins, external pusher plates or similar external mechanical means of initiation are more sensitive than submunition fuzes with all-internal fuzing mechanisms. All-internal fuzing mechanisms are generally less sensitive to motion and impact. EOD or UXO-qualified personnel should evaluate the fuzing system to determine its relative sensitivity.

(b) *Density of submunitions in the area.* The greater the density, the higher the probability of accidental contact and accidental initiation. Areas with only 1 to 2 submunitions per acre are considered low density. Areas with 3 to 40

submunitions per acre are considered medium density, while areas with 41 or more submunitions per acre are considered high density.

(c) *Type of activity to be conducted.* Anomaly avoidance in support of environmental sampling (for example, soil sampling, emplacing monitoring wells) presents less chance for accidental detonation than surface clearance during range clearance activities or a surface removal during a munitions response. A surface removal may present less of a chance for accidental detonation than a subsurface removal.

(d) *Vegetation.* Dense vegetation (for example, brush, grass, leaves), which can prevent visual detection of submunitions and increase the chance of accidental detonation should be burned off prior to the conduct of range clearance activities or surface removals to reduce the risk to personnel.

## **19–9. Unexploded ordnance**

### *a. General.*

(1) The UXO are considered the most dangerous category of military munitions. However, other military munitions that are encountered outside the Army's munitions logistics management system and/or have experienced abnormal environments should be considered equally dangerous and managed as UXO until assessed and determined otherwise by technically-qualified personnel (for example, EOD personnel, UXO-qualified personnel). Munitions that have experienced abnormal environments include, but may not be limited to, munitions remaining after attempted demilitarization by OB or OD; munitions involved in accidents or fires; munitions or components subjected to certain tests (for example, fuze arming tests, jolt and jumble tests) that might cause arming.

(2) The UXO will most likely be found in areas that the Army currently uses (for example, operational ranges) or once used (for example, former ranges) for military munitions training or testing, and in areas where contingency, combat or military operations other than war have occurred. For a variety of reasons, UXO can also be encountered in other areas.

### *b. Disposition of unexploded ordnance.*

(1) Agencies designing and executing munitions response actions shall work collaboratively with environmental regulators and safety officials toward resolving, in a mutually agreeable manner, any concerns with the planned disposition of UXO during a response action; however, the protection of people, to include Army response personnel, from the hazards associated with UXO and with the disposition of UXO is paramount.

(2) There are no safe procedures for moving, rendering safe or destroying UXO, but merely procedures considered less dangerous. Destruction-in-place (referred to as either blow-in-place or BIP) is the least dangerous; therefore, the preferred method for UXO destruction.

*c. Unexploded ordnance compliance.* Army response actions to address UXO must comply with these standards other applicable Army and DOD policies, and with applicable Federal, tribal, State, and local laws, regulations, statutes, and agreements. Agencies designing response actions to UXO must ensure that, if not already in place, protective measures (for example, site access control for Army installations; public awareness for FUDS) are implemented as quickly as practicable following discovery. Should environmental regulators and safety officials have concerns regarding the sufficiency of the protective measures to be taken, these concerns should be raised to HQDA, Deputy Assistance Secretary for Environment, Safety and Occupational Health for resolution. Protective measures must be maintained during any delay caused by—

(1) Compliance with laws, regulations, statutes and/or agreements.

(2) The need to address concerns raised by environmental regulators and safety officials about:

(a) Methods for managing any potential adverse impacts (for example, harming endangered species, damaging cultural resources) of implementing a pending BIP operation.

(b) The use of alternative (to BIP) disposition methods.

(c) Other factors (for example, weather).

*d. Unexploded ordnance qualification.* The UXO shall not be moved, unless EOD or other technically qualified personnel (UXO-qualified personnel specifically authorized by the Army) determine that the risks associated with movement are acceptable. Although environmental regulators and safety officials recognize the expertise of Army personnel involved in UXO disposition decisions, they may challenge an Army field expert's decision and seek to elevate their concerns to higher levels of authority for resolution.

(1) If technically qualified personnel determine that the risk associated with movement is unacceptable, or if the munition's condition precludes an adequate assessment the risk of moving it then it should be BIP.

(2) In some circumstances, EOD personnel may determine that only careful movement of a UXO, for a limited distance, using prescribed EOD procedures, is necessary and allowed by EOD procedures. In such circumstances, destruction by detonation will occur in the general vicinity of discovery.

(3) Under some circumstances, when BIP does not pose an immediate, certain and unacceptable risk to people and/or to critical operations, facilities or equipment, environmental regulators and safety officials may seek collaboration with the Army agency designing or conducting the response to mutually agree to mitigation measures to reduce potential impacts of the pending BIP to public safety, the environment and cultural resources.

(4) When BIP poses an immediate, certain and unacceptable risk to people and/or to critical operations, facilities or equipment, EOD personnel may determine that render safe procedures (RSP) should be attempted.

(a) Only EOD personnel are authorized to conduct RSP.

(b) Because the application of RSP exposes EOD personnel to added risks (greater than BIP), the application of RSP shall only be attempted in limited circumstances.

(c) Should EOD personnel employ RSP, protective measures shall be applied to mitigate potential explosive effects.

(d) EOD personnel shall perform RSP per Joint Service EOD Technical Data.

(e) When the condition of UXO (for example, crushed, bent, broken, mangled) precludes strict adherence to published procedures, on-site EOD personnel will determine and perform the procedure-established or innovative-that will have the most probable degree of success to render the munition safe, while mitigating potential explosive effects.

(f) The on-site EOD supervisor or, in the case of munitions responses, the UXO safety officer shall ensure that the detonation site is inspected after each detonation, or any misfire. No one shall be allowed within MSD from the detonation site until the on-site EOD supervisor or UXO safety officer declares the area is safe.

e. Before UXO that may pose an explosive hazard may be transported or shipped over public transportation routes, EOD personnel must determine whether the UXO is safe for transport. A determination that the UXO is safe for transport must be documented in the EOD incident report. A copy of the incident report must accompany the shipment.

#### **19–10. Firefighting in areas known or suspected to contain munitions and explosives of concern**

a. See also <https://www.denix.osd.mil/uxosafety>.

b. Advanced planning is essential for firefighting operations involving areas that are known or suspected to contain MEC. Coordination of such plans between firefighters and explosives safety personnel or EOD personnel is essential.

c. Senior firefighting personnel should carefully assess whether to fight a fire involving areas that are known or suspected to contain explosive hazards. Factors to consider include, but are not limited, to: the types of munitions that might be present, the safety of firefighting personnel and of the public, the potential loss of critical assets, and the duration and intensity of the fire.

d. When the decision is made not to fight such fires:

(1) Evacuate the area. The Commander and/or designated fire and safety department personnel shall determine safe evacuation distances. In the absence of such, evacuate to maximum fragment distance (see para 19–12).

(2) Remain out of the area until it has cooled for at least 24 hours.

e. When the decision is made to fight such fires, all firefighters involved in fighting the fire should be provided basic safety training for fighting fires involving military munitions. The decision to fight such a fire is made by the installation Commander in consultation with fire and safety department personnel. To assess the risk to firefighters, use table 8–14, “Hazard Division 1.1 Hazardous Fragment Distances”. To find a separation distance that provides a level of risk acceptable to the installation Commander and his or her firefighting and safety departments, use table 8–14 in conjunction with the algebraic manipulations described below.

(1) Identify the round with the largest NEW known or suspected to be on or within 3 inches of the surface in the firefighting area.

(2) Using the NEW for this round, find its hazardous fragment distance in table 8–14. For example, if the round has an NEW of 6 lbs, the hazardous fragment distance is 434 feet.

(3) Fighting a fire at the separation distance provided by table 8–14 exposes firefighters to a 1 percent chance of death or serious injury from each detonation of that round.

(4) Fighting fires at distances greater or less than the table 8–14 distance changes the 1 percent probability in inverse proportion to the square of the change in distance. For example, if the separation distance is halved (in other words, the halved distance= $(.5)(\text{the table 8–14 distance})$ ), the risk increases by the square of the inverse of the reduction. The square of the inverse of the reduction= $(1/.5)^2=4$ . This means that fighting a fire at half the table 8–14 distance increases the risk of death or serious injury from the detonation of a single round by a factor of four; specifically, from 1 percent to 4 percent. Similar calculations can be performed to assess risk for other reductions, or increases, to the table 8–14 hazardous fragmentation distance.

#### **19–11. Controlled burns in areas known or suspected to contain munitions and explosives of concern**

Controlled burns in areas known or suspected to contain MEC are permitted provided proper safeguards are in place to protect all personnel from unintentional detonations. These burns must be carefully planned and executed to manage potential explosives safety risks and environmental effects. During such burning operations, all personnel shall be at MFD from the burning or burned area, based on the munition with the greatest maximum fragmentation distance (MG MFD), and shall remain out of the area until it has cooled for at least 24 hours. (See paragraph 19–12. for an explanation of MFD and MG MFD.)

## 19-12. Quantity-distance criteria for munitions response actions

For QD purposes, assume MEC is 1.1., unless historical and physical evidence indicates that only 1.3 or 1.4 munitions are present at a munitions response site (MRS).

a. Establishing the MGMFD, the munition with the greatest hazardous fragment distance (MGHFD), the munition with the greatest fragment penetration capability (MGFPC), the munition with the greatest blast hazard (MGBH), and the MCE. Each of these five terms is defined in the paragraphs immediately below:

(1) *Munition with the greatest maximum fragmentation distance.* Each munition has a calculated MFD. The MFD is the calculated maximum horizontal range of primary fragments from the detonation of a munition. The MGHFD is the munition with the greatest MFD that can reasonably be expected to be present at any particular MRS. The MGHFD is used to establish MSD around many types of munitions response activities that involve MEC (see 19-12b.).

(2) *MGHFD.* Each munition has a calculated hazardous fragment distance (HFD). The HFD is the distance to which a munition will project hazardous fragments to a density of 1 per 600 square feet. The HFD is equal to IBD (based on fragmentation) for QD purposes. The MGHFD is the munition with the greatest HFD that can reasonably be expected to exist in any particular MRS. The MGHFD is used to establish MSD around many types of munitions response activities that involve MEC (see para 19-12b).

(3) *MGFPC.* Each munition's primary fragments have calculated penetration capabilities into various types of materials (for example, steel, earth, concrete, LEXAN, bullet-proof glass). The MGFPC is the munition with the greatest fragment penetration capability that can reasonably be expected to exist in any particular MRS. The MGFPC is only used to determine shielding thickness for those mechanized MEC operations that require such (see para 19-12b(7)).

(4) *MGBH.* The MGBH is the munition with the greatest NEWQD at an MRS. The MGBH is used to establish MSD from many types of munitions response activities that involve MEC (see para 19-12b).

(5) *MCE.* The term MCE, as used in a munitions response that does not involve chemical warfare material applies to explosive soil, buildings and installed equipment that contain explosives residues potentially presenting an explosive hazard.

(a) For removal and treatment of explosive soil, establish the MCE in pounds of explosive. The MCE is the weight of the mix multiplied by the concentration of explosive (for example, 1,000 lbs explosive soil with 10 percent TNT has an MCE of 100 lbs). When concentration varies within an area, weighted averages or any other valid mathematical technique can be used as long as the technique can be explained and technically supported (for example, in the explosives safety submission).

(b) For buildings that may contain significant amounts of explosives residues that potentially present an explosive hazard (see para 19-7), establish an MCE in pounds of explosive. The MCE must be estimated on a case-by-case basis by personnel familiar with the explosives operations conducted in a building. If such an estimate is not possible, then an MCE of 100 lbs is a conservative default.

(6) A web page maintained by DDESB lists, for a wide array of munitions, the MFD, the HFD, fragment penetration capability, and NEWQD. (Note: the JHCS is the official source of NEWQD.) Contact DDESB at 703-325-2525 for access instructions to this Web page. If, after access is obtained, the munition of interest is not listed, contact the USACE's Military Munitions Center of Expertise (MMCX) at 256-895-1653 and request a calculation.

b. *MSD around MEC operations.* Unless DDESB-approved engineering controls (see para 19-12.(8)) are used to mitigate blast, fragments, or crater ejecta, the following MSD apply.

(1) Preliminary site work (for example, preliminary assessments, site visits, surveying, marking search lanes, geophysical investigation) that does not involve ground disturbing or other intrusive activities, intentional contact with MEC or placement of explosives on the MRS do not require an explosives safety submission (for example, an munitions response explosive safety submission (MRESS) or explosives safety site plan) or the establishment of MSD. However, project personnel may be more restrictive applying MSD when considered appropriate.

(2) Surface or subsurface removal includes removal of MEC both during the investigation of anomalies and during a munitions response action. The MSD to nonessential personnel and corresponding QD siting shall be established on the basis of an unintentional (accidental) detonation of a single MEC.

(a) For removal of UXO, the MSD to nonessential personnel shall be the greater of K40 or the MFD that will be based on the MGHFD. However, the MSD based on MFD may be reduced to HFD, which will be based on the MGHFD, if a risk assessment shows that the reduction is acceptable. The risk assessment shall account for the fuze sensitivity (a function of fuze design, fuze condition, and armed/unarmed status), the number of nonessential personnel that would be exposed by a reduction from MFD to HFD, and any other mitigating factors.

(b) For removals of MEC that have been determined not to be UXO (for example, DMM), the MSD shall be the greater of K40 or HFD based upon the MGHFD.

(c) In day-to-day operations, the MSD to nonessential personnel need only extend from the specific grid or grids in which munitions response activities are ongoing, rather than from the boundaries of the entire MRS. For situations where inhabited areas are in close proximity, it is permissible to apply the MSD from each individual dig, rather from the grid, to minimize evacuations or the erection of engineering controls. Additionally, it is not always necessary to

worst-case the entire MRS. That is, different MGMFD for UXO or MGHFD for DMM can be used for individual digs in a grid, if a geophysical prove-out has shown that the detection system can reliably discriminate between munitions with different MGMFD and different MGHFD.

(d) Munitions responses to MEC shall be separated from AE storage locations by 1.1 IMD (K11), based on an unintentional detonation of one MGBH at the intrusive operation.

(e) Team Separation Distance (TSD) during surface or intrusive munitions response to MEC is based on blast overpressure, as computed by the formula:  $D=40W^{1/3}$ .

(3) Intentional detonations of MEC. MEC may “blown in place” (BIP), consolidated on the MRS with other MEC and detonated, moved within an MRS grid and detonated, or moved to a designated demolition area within the MRS and detonated per the conditions outlined in the MRESS. Regardless, use the greater distance of K328, which will be based on the NEW of all MEC and the donor explosives used in the shot, or MFD, which will be based on the MGMFD in the shot.

(4) Explosive soil operations. The MSD to nonessential personnel shall be the IBD as listed in table 8–8 using the “Other PES” column.

(5) Buildings with explosive residues. (See para 19–7d(2).)

(6) Magazines used to store demolition (donor) explosives or recovered MEC.

(a) Site magazines per chapter 8 of this pamphlet.

(b) No specific separation distance applies from storage magazines to essential personnel or authorized visitors.

(c) In some cases, a portable magazine will be placed within the MRS. If a portable magazine is placed within the MRS, any MEC detected must be removed from the footprint of location of the magazine and from an area within 75 feet of the magazine’s footprint. After removal, place the magazine and continue the removal beyond 75 ft from the magazine. This will ensure that removal operations conducted at 75 ft or more from the magazine provide the required IMD to the magazine. The 75-foot separation distance is a conservative default distance that is based on preventing the prompt propagation of explosives in the magazine from an accidental detonation of up to 200 lbs 1.1 (e.g., from a 500 lb bomb) during intrusive operations. If project personnel want to conduct removals at a lesser distance than 75 feet from the magazine and the largest NEW of any MEC item at the MRS is less than 200 lbs, then a lesser distance may be used based on 1.1 IMD prescribed in chapter 8 (use K11 and the net explosive weight for quantity-distance (NEWQD) of the MGBH).

(7) Mechanized MEC processing involving intentional contact with MEC (for example, sifting; trommel-spinning; magnetic or eddy-current metal separating; crushing, shredding). Such operations shall be treated as a remote operation for QD purposes, unless a risk assessment per AR 385–10 indicates that the risk (a combination of probability of accidental detonation and the severity of effect, given detonation) is very low (Risk Assessment Code (RAC) 5). For RACs 1–4, the following apply:

(a) Protection of essential personnel. For protection from fragments, the design munition shall be the MGFPC. Essential personnel shall be protected by shields or barricades designed to defeat fragments from the MGFPC. For protection from blast, use the NEW of the MGBH. Essential personnel shall be separated by K24 based on the NEW of the MGBH. Exceptions: if operators are wearing double hearing protection, they may be located at K18.

(b) Protection of nonessential personnel. High Input (for example, shredding): Use MFD to nonessential personnel. Low Input (for example, sifting): Nonessential personnel shall be separated from sifting operations by MFD based on the MGMFD.

(8) Engineering controls. A variety of DDESB-approved engineering controls can reduce QD during a munitions response to MEC. (See DDESB Tech Paper 15 or contact USATCES for further information.)

(a) Method for Predicting Primary Fragmentation Characteristics of Cased Explosives. This method is used to provide fragment mass and velocity data for input into other methods to predict MFD and HFD. The method can be used only by qualified engineering organizations (for example, USACE’s MMCX).

(b) Method for Calculating Range to no More Than One Hazardous Fragment per 600 Square Feet. The method can be used only by qualified engineering organizations (for example, USACE’s MMCX).

(c) Miniature Open Front Barricade. This barricade is used to reduce QD during intrusive removal operations where the MGMFD is 81mm in diameter or smaller.

(d) Open Front and Enclosed Barricades. These barricades are used to reduce QD during intrusive removal operations where the MGMFD is 155mm in diameter or smaller.

(e) Procedures for Demolition of Multiple Rounds (Consolidated Shots) on Ordnance and Explosives (MEC) Sites. This procedure stipulates how to physically configure projectiles, bombs, and warheads for a multiple round shot to avoid increasing the QD due to interaction effects among the projectiles.

(f) Use of Water for Mitigation of Fragmentation and Blast Effects Due to Intentional Detonation of Munitions. This method describes how to use water containers (for example, a child’s swimming pool) to reduce the QD from intentional detonations of MEC that is 155mm in diameter or smaller.

(g) Use of Sandbags for Mitigation of Fragmentation and Blast Effects Due to Intentional Detonation of Munitions.

This method describes how to use sandbags to reduce the QD from intentional detonations of MEC that is 155mm in diameter or smaller.

(h) Buried Explosion Module (BEM): A Method for Determining the Effects of Detonation of Buried Munitions. This method describes how to use earth cover to reduce the QD from intentional detonations of MEC of any size.

(i) Contained Detonation Technology. This technology, which is mobile, can destroy munitions of various sizes based on the DDESB-approval for each chamber. This technology, which reduces reliance on open detonation, provides for on-site destruction.

c. Essential personnel and authorized visitors. The executing agency is responsible for determining those personnel essential for the operation being performed.

(1) Essential personnel may include, but may not be limited to EOD personnel, UXO technicians, and UXO-qualified personnel.

(2) Non-essential personnel are all personnel that are not essential for an operation.

(3) Authorized visitors include those non-essential personnel who have need to temporarily enter an MSD. The on-site safety officer (government or contractor) will determine those persons to who access will be authorized, and the conditions (for example, areas of access, requirement for escort, time of access) of such access. When possible, access should be limited to those periods when munitions response activities (for example, intrusive operations) other activities that directly involve the handling or processing of MEC are not being conducted.

### 19–13. DOD required safety submissions

Munitions response explosives safety submissions (MRESS) (also referred to as explosives safety submissions (ESS)) address explosives safety requirements for munitions responses (for example, field activities) that involve the intentional physical contact with MEC or the conduct of ground-disturbing or other intrusive activities in areas known or suspected to contain MEC. In contrast, site plans (explosives safety site plans and chemical warfare material site plans) address spatial relationships between PESs and ESs based on the deterministic QD criteria for exposure, placement, and construction of the PES and ES. Some MEC activities require an MRESS, while others may only require a site plan. See table 19–3 to determine when MRESS and site plans are required. See paragraphs 19–15 to 19–19 for descriptions of the required contents of MRESS and site plans.

a. Agencies or installations conducting a munitions response to MEC should submit the MRESS or site plan to USATCES 90 days before the planned start of munitions response activities that involve intentional physical contact with MEC or the conduct of ground-disturbing or other intrusive activities in areas known or suspected to contain MEC or the placement of explosives on site. USATCES will provide Army-level approval and forward the MRESS or site plan to DDESB for review and DOD-level approval.

*Note.* (Electronic submissions are preferred. For hard copy, submit 2 copies to USATCES.)

b. Routing and approval.

(1) For Army installations that are closing or closed due to BRAC decisions or other reason, the installation shall send the submittal (that is, MRESS or site plan) to the BRAC office. The BRAC office will provide ACOM, ASCC or DRU-level approval and forward to USATCES. If the installation is not staffed, then the installation's supporting BRAC office shall send the MRESS or site plan to USATCES. USATCES will review the MRESS or site plan and provide Army-level approval and forward it to DDESB. DDESB will review and provide final DoD-level approval.

(2) For active Army installations, the IMCOM Regional Office shall forward the submittal to USATCES. USATCES will review, provide Army-level approval and forward it to DDESB. DDESB will review and provide final DoD-level approval.

(3) For FUDS, the USACE Division, District, or Center shall forward the submittal to the USACE MMCX. The MMCX will provide ACOM, ASCC, or DRU-level approval and forward to USATCES. USATCES will review the ESS and provide Army-level approval and forward it to DDESB. DDESB will review the ESS and provide final DOD-level approval.

c. When circumstances dictate, USATCES, in coordination with the agency having ACOM, ASCC or DRU-level approval authority for MRESS, may approve initiation of munitions response activities that involve the placement of explosives on a site, intentional physical contact with MEC or the conduct of ground-disturbing or other intrusive activities in areas known or suspected to contain MEC prior to DDESB approval of the MRESS or site plan. Such approvals, which are the exception, not the rule, are made on case-by-case basis and are site specific. The following criteria apply:

(1) USATCES must have approved the submittal.

(2) The USATCES-approved submittal must be at the DDESB for review and approval.

(3) The initiation of the affected munitions response activities must be justified.

(4) The ACOM, ASCC, or DRU and executing agency must accept the fact that the DDESB approval process may impose different or additional requirements.

d. USATCES will inform Office of the Deputy Assistant Secretary of the Army for Environment, Safety, and Occupational Health (ODASA (ESOH)) of the decision to proceed and supporting rationale.

**19–14. DOD required safety submissions for munitions responses to munitions and explosives of concern**

There are various types of munitions response actions to MEC, and MRESS and site plan requirements vary accordingly. These requirements are listed in table 19–2.

<b>MEC activity</b>	<b>Required safety submission</b>
Explosives or munitions emergency response	None
Site visits (with no intentional physical contact with MEC) to support non-intrusive investigation activities (for example, range inventory, Inventory Project Report (INPR), Archives Search Report (ASR), Preliminary Assessment (PA), Site Inspection (SI))	None
Non-intrusive investigation activity results in a “No DOD Action Indicated” (NDAI) decision	NDAI MRESS See paragraph 19–15.
Time-critical removal action (TCRA)	TCRA MRESS See paragraph 19–16.
Surface or intrusive sampling during SI, Engineering Evaluation/Cost Analysis (EE/CA), or Remedial Investigation/Feasibility Study (RI/FS)	Explosives Safety Site Plan See paragraph 19–17.
SI, EE/CA, or RI/FS or results in a signed “No DOD Action Indicated” (NDAI) decision document	NDAI MRESS See paragraph 19–15.
Construction support, where the probability of encountering MEC is low	None
Construction support, where the probability of encountering MEC is moderate to high and a removal action must therefore be conducted prior to or during the construction	For TCRA: TCRA MRESS See paragraph 19–16.  For NTCRA: MRESS See paragraph 19–19.
Non Time-Critical Removal Actions and Remedial Actions	MRESS See paragraph 19–19.
Anomaly Avoidance	None
UXO Escort	None

**19–15. “No DOD action indicated” or “no further action” MRESS**

Submit an NDAI or NOFA MRESS to USATCES 60 days before the date the decision document is projected to be signed. An NDAI or NOFA MRESS will, at a minimum, provide the following:

- a. The site identification (for example, name, unique identifier).
- b. The site location.
- c. Justification for the decision.

**19–16. TCRA MRESS**

a. Submit a TCRA MRESS to USATCES 60 days before the munitions response to MEC (removal action) is scheduled to begin.

b. A TCRA is conducted to address immediate MEC hazards at a site, and a non-time critical removal or remedial action is done later to address remaining hazards.

c. The TCRA MRESS will contain the following site-specific information.

- (1) The site identification (for example, name, unique identifier).
- (2) The TCRA site name and location.
- (3) TCRA’s purpose, in sufficient detail to explain the reason the TCRA was authorized. Example: “UXO (81mm HE mortar rounds) were discovered washed up on the beach at the Flowery State Recreation Area. A TCRA is required to remove the immediate hazard to users of the Recreation Area.”
- (4) The estimated date that on-site TCRA activities will be:



- (a) Initiated.
- (b) Completed.
- (5) The MGMFD, the MGHFD, the MGBH, the MGFPC, and the MCE (provide only those that apply; see para 19–12)
- (6) Scaled ESQD maps that show the MSD for:
  - (a) The removal area(s) within the area covered by the TCRA.
  - (b) Areas for intentional detonations.
  - (c) Areas or magazines for the storage of demolition explosives or MEC.
- (7) Actions and controls to be implemented (for example, surface removal, subsurface removal, evacuation, fences) as part of the TCRA.
- (8) DDESB-approved engineering controls (see Technical Paper 15) to be used, if any.
- (9) A point of contact for additional information.

**19–17. Explosives safety site plan for surface or intrusive investigation in support of a munitions response to MEC**

An explosives safety site plan is required for explosives operations on an MRS in support of any munitions response action (for example, surface removal, anomaly investigation EE/CA, and RI/FS) that could result in a need to destroy any MEC encountered. Provide the following:

- a. The MGMFD, the MGHFD, the MGBH, the MGFPC, and the MCE (provide only those that apply; see para 19–12)
- b. Scaled ESQD maps that show the MSD for—
  - (1) The MRS (acreage, parcels, and so forth) at which the investigation will be conducted.
  - (2) Areas to be used for any intentional detonations.
  - (3) Areas or magazines used for the storage of demolition explosives and, when appropriate, any MEC encountered.

**19–18. Construction support munitions response explosives safety submission**

Construction support may be required during intrusive activities (for example, development, laying or repairing utilities, improving roads) on property known or suspected to contain MEC. When the probability of encountering MEC has been determined to be moderate to high a MRESS for construction support will be submitted. The construction support MRESS should contain the information required per paragraph 19–19, but may be tailored based on the circumstances (for example, TCRA per paragraph 19–16).

**19–19. Selected munitions response munitions response explosives safety submission**

A munitions response to MEC requires a detailed MRESS. Much of the information required for an MRESS can be found in documents (for example, Historical Archives Search Reports, reports of an SI) developed per applicable laws and regulations in preparation for a munitions response to MEC. The MRESS should be submitted to USATCES at least 60 days prior to planned start of munitions response activities that involve intentional physical contact with MEC or the conduct of ground-disturbing or other intrusive activities in areas known or suspected to contain ME. The MRESS will include the following:

- a. *Background.* Provide:
  - (1) A brief description of the munitions-related activities that occurred at the MRS that led to the known or suspected presence of MEC
  - (2) The reason for the munitions response.
  - (3) The scope of munitions response activities
    - (a) Number of acres.
    - (b) Type of response (for example, removal or remedial action, removal or remedial action with land use controls, removal or remedial action with land use and engineering controls, removal or remedial action that involves a landfill known or suspected to contain MEC, soil removal, building demolition).
  - (4) The MGMFD, the MGHFD, the MGBH, the MGFPC, and the MCE (provide only those that apply; see para 19–12).
- b. *Maps.*
  - (1) *Regional map.* Provide a map showing the location of MRS within the state or region.
  - (2) *MRA (MRS) map.* Provide the large-scale map of the entire MRA or MRS showing the following:
    - (a) Any MRS addressed by the MRESS.
    - (b) Any NDAI or NOFA acreage within the MRA.
    - (c) Any MRS subject to the MRESS, but covered by a previous MRESS.
    - (d) Any MRS that is not the subject of the MRESS, but that may be investigated by a different or future MRESS.
  - (3) *Munitions response site map.* Provide a map of the MRS addressed by the MRESS (for example, the acreage to be subjected to a removal action, land use controls, remedial action, and so forth, under the MRESS). This MRS map

should be at a scale of 1 inch equals no more than 400 feet unless the MRS is so large that the map cannot be printed on standard 8½ by 11 inch paper. Show the following on the MRS map.

(a) *Unintentional detonations.* Draw an arc around the MRS showing the MSD to nonessential personnel from unintentional detonations during intrusive activities. Identify each exposure within the MSD (for example, buildings, facilities, roads, recreational areas, above and below ground utilities).

(b) *Intentional detonations.* Draw a maximum fragmentation distance arc around the area or, if DDESB-approved engineering controls are used, draw the applicable MSD arc for the engineering control. Identify each exposure within the arc.

(c) *Storage.* Storage areas or magazines used to demolition explosives and, when required, an MEC recovered. Draw an IBD arc around each storage location. Identify each exposure within the IBD arc.

(d) *Explosive soil.* For areas containing soil presenting explosives hazards (explosive soil):

1. Provide a map outlining the areal extent of such soil.

2. Draw an IBD QD arc around the area (see para 19–12b(4)). Identify each exposure within the IBD arc.

(e) *Buildings.* For buildings containing explosives residues that present explosives hazards (see paragraph 19–7):

1. Provide a map showing the footprint of the building(s).

2. Draw a MSD arc around each building (see para 19–7d(2)). Identify each exposure within the IBD arc.

(f) *AE storage locations for demolition materials and recovered MEC.* Draw an IBD arc around each location. Identify each exposure within the IBD arc. State type of storage (for example, earth-covered magazine, standard aboveground magazine, shed, open storage pad, commercial portable magazine). Provide explosives limits for each storage location (for example, “100 lb NEW of hazard class 1.1). State that the lightning protection system will be installed, inspected and tested in accordance with this pamphlet.

c. *Land use.* Provide—

(1) For property intended for release outside DOD (such as BRAC), the anticipated reuse of the area.

(2) For property not under DOD control (such as FUDS), the current use and, if known, the anticipated future use of each site. List any existing land use controls that limit exposure to MEC.

d. *Types of munitions.* Based on historical records and/or investigation, provide:

(1) The types of munitions expected to be encountered in the MRS. Be as specific as possible (for example, “Projectile, 105mm, HE, M1,” “Rocket, 66mm, Light Anti-Tank Weapon”)

(2) The expected depths of MEC to be encountered in the MRS. More than one depth may be listed, because the depth may vary for different types of munitions and also may vary from one part of the MRS to another part.

e. *Removal depths.* Indicate the planned removal depths. (Normally, removal to detected depth should be used.)

f. *Start date.* Provide the expected date that munitions response activities that involve the placement of explosives on-site, the intentional physical contact with MEC, or the conduct of surface or subsurface removal activities in the MRS are scheduled to start. Indicate the potential consequence, if any, if DDESB approval is not obtained by the start date. (Note: Site preparation activities (for example, surveying, gridding, vegetation removal, mag and flag, geophysical surveying, geophysical prove-out) may be conducted while awaiting DDESB approval of an MRESS.)

g. *MEC migration.* Describe naturally occurring phenomena (for example, drought, flooding, erosion, frost heave, tidal changes) that could cause the migration or exposure of MEC, and procedures for monitoring and managing such.

h. *Access control.* Describe measures to be taken to prevent access by nonessential personnel to areas within the MSDs established (for example, road blocks, warning signs, guards, and so forth).

i. *Detection equipment and response techniques.* The intent of this section is to describe the capabilities of detection equipment relative to the degree of removal required to support the current, determined, or reasonably anticipated end use.

(1) Describe the techniques to be used to detect and remove MEC (for example, mag-and-flag; geophysical survey; hand digging, mechanical excavation).

(2) Identify the types of detection equipment to be used and the areas in which they will be employed.

(3) Summarize methods used (for example, test plots) to establish the expected detection capabilities of the equipment used. If anomaly discrimination will be used, explain what methods will be used to establish the expected accuracy of the discrimination.

(4) When describing the detection methods:

(a) Describe the rationale (for example, best available technology based on geology, topography, munitions characteristics) used to select the detection methods and technologies to be used during the response.

(b) Address any limitations (for example, equipment, terrain, soil type) and mitigating actions, if any.

(c) Provide a statement that the equipment can detect each type of munition known or suspected to be present at the site to the stated removal depth. If the removal is a “removal to depth” (for example, to depth of detection), then state the depth the equipment can detect each kind of MEC at the site.

j. *QA/QC.* Describe QA/QC standards and pass/fail criteria for QA/QC control audits.

k. *Disposition techniques.*

(1) MEC—

(a) Briefly, describe the MEC disposition techniques (for example, OB, OD, contained detonation, incineration) to be used.

(b) When recovered MEC cannot be destroyed within the MRA or MRS, address how explosives safety requirements will be met during transportation and during off-site storage, treatment or disposal. (Note: disposition actions should consider guidance applicable to waste military munitions.)

(2) Material Potentially Presenting an Explosive Hazard (MPPEH). Describe the process to be used to manage MPPEH, material documented as exposed hazard (MDEH) and material documented as safe hazard (MDAS).

(3) Explosive Soil. Address methods (for example, blending, bio-remediation) to be used to reduce explosives concentrations to a non-reactive level. Address methods (for example, wetting the soil before blending) to be used to reduce any explosive hazards.

*l. Environmental, ecological, cultural, and/or other considerations.* Address any environmental, ecological (for example, endangered species), cultural (for example, tribal spiritual or gathering sites) and/or other factors that impacted, from an explosives safety perspective, the selection of the munitions response.

*m. Technical support.* Summarize EOD, Technical Escort Unit (TEU), or UXO-technician or UXO-qualified personnel support that may be required.

*n. Residual Risk Management.* No removal action is 100 percent effective; therefore, the MRESS will describe—

(1) *Land use controls.* The MRESS must summarize any LUC to be implemented and maintained on the property.

(2) *Safety education program.* Address methods to be used to educate the public about the risks associated with residual MEC. (Note: Such programs will be based on the Army's 3Rs Explosives Safety Program, see <https://www.denix.osd.mil/uxosafety>.)

(3) *Long-term management.* Describe how any potential residual risks due to MEC will be managed (for example, recurring reviews).

*o. Stakeholder involvement.* Briefly, summarize how stakeholder concerns affecting the explosives safety aspects of the selected munitions response were addressed (for example, public meetings, public notifications, stakeholder involvement in decision making process, education programs).

*p. Contingencies.* To reduce the need to submit amendments and corrections, an MRESS may describe alternative actions that could be used to address contingencies. Examples:

(1) Alternative DDESB-approved engineering controls that may be used under specified conditions.

(2) Alternative detection equipment.

(3) Alternative QA/QC procedures.

(4) Alternative removal techniques (for example, mag and flag vs geophysical survey; hand digging vs. digging by excavator)

(5) Alternative disposition techniques (such as, open detonation vs. contained detonation chamber vs. transport off-site).

## **19–20. Amendments and corrections to munitions response explosives safety submission and site plans**

*a.* Amendments reflect substantive changes to the MRESS or site plan and therefore require USATCES and DDESB review and approval. Corrections reflect minor changes to the MRESS or site plan and, therefore, are submitted to USATCES and DDESB for information only.

*b.* Normally, an amendment or correction to an MRESS or site plan does not require resubmission of the affected MRESS or site plan. The information submitted must be in sufficient detail to identify the specific MRESS or site plan being amended or corrected, the affected portions, and the precise amendments or corrections.

*c.* Amendments are only required when a change to an approved MRESS or site plan increases explosives safety risks, identifies requirements for additional or increased explosive hazard controls, or increases or decreases an ESQD arc.

(1) An amendment normally requires USATCES and DDESB approval before the affected munitions response actions can continue. However, munitions response activities need not be stopped pending such approval provided:

(a) The amendment pertains to an area for which an MRESS has already been approved. This includes situations where the amendment is merely increasing the size of the previously approved area.

(b) The agency executing the response institutes protective measures to address any explosives risks and accepts the possibility that the approval process may impose additional requirements.

(2) If the amendment is for a new area (for example, MRA or MRS), then USATCES and DDESB must approve the amendment before the start of munitions response activities that involve intentional physical contact with MEC or the conduct of ground-disturbing or other intrusive activities or the placement of explosives on the MRS.

(3) To allow the munitions response to continue with minimal interruption, amendments should be submitted electronically.

(4) Changes that require an amendment include:

(a) Constraints in funding, technology, access, and other site-specific conditions that impact the degree of removal addressed in the approved MRESS.

(b) Any change in the MSD or ESQD arcs, regardless of cause.

(c) Changes in LUC, to include changes in management or long-term monitoring procedures to address residual explosives hazards.

d. Corrections. MRESS corrections address changes to the approved MRESS that do not increase explosives safety risks or exposures. MRESS corrections:

(1) Do not require approval.

(2) Are primarily administrative in nature and provided for information purposes.

#### **19–21. After action reports**

a. An AAR is required for all munitions responses completed per a DDESB-approved MRESS. The AAR's purpose is to document that the explosives safety aspects of the selected response have been completed per the approved MRESS, not to obtain USATCES or DDESB approval or verification that the munitions response is complete. In most cases, a "Statement of MEC Removal" or a "Statement of Munitions Response MEC Removal Actions" fulfills the requirements of paragraph 19–21d. The DDESB shall acknowledge receipt of an AAR, and raise any issues that require resolution before land transfer or an alternative use can safely proceed.

b. Submit AAR to USATCES 60 days before the land transfer or alternate use is scheduled.

c. USATCES and DDESB will retain the AAR in their files; however, the agency or installation that conducted the munitions response is responsible for maintaining detailed, permanent records necessary for historical purposes.

d. After action reports must:

(1) Summarize the MEC found.

(2) Describe the relative effectiveness and any limitations of the technologies used during the munitions response and the effects on residual risk relative to that originally projected.

(3) Explain, in cases where response actions were not performed, the rationale for not addressing those areas (for example, a mass of buried reinforced concrete; presence of endangered species).

(4) Include maps showing—

(a) Areas from which MEC was removed.

(b) Areas within acreage covered by the AAR where response actions were not performed (see para 19–21d.(3)).

(5) The known or reasonably anticipated end uses of the acreage covered by the AAR.

(6) Summarize the LUC that were implemented, if any, and the areas to which they apply.

(7) Address provisions for long-term management.

#### **19–22. Transfer or lease of real property**

a. *Transfer from DOD control.* Real property known or suspected to contain MEC must not be leased or transferred from DOD control until a munitions response consistent with the determined or reasonably anticipated land use, from an explosives safety perspective, has been completed per a DDESB-approved MRESS.

(1) Real property containing MEC may be transferred from DOD control prior to a munitions response, provided:

(a) The DESOH approves the transfer or lease.

(b) The DDESB approves the explosives safety provisions for the transfer or lease (for example, Environmental Services Cooperative Agreement, Land Use Control Implementation Plans).

(c) The receiver is advised of any known or suspected explosive hazards present.

(2) For real property that has been subjected to a munitions response, but still contains residual explosive hazards, records that document the transfer must:

(a) Notify the receiver of details of any past removal or remedial actions.

(b) Notify the receiver that detection and removal methods are not 100 percent effective, and that some residual hazards may remain.

(c) Notify the receiver not to excavate or drill beyond the removal depth without appropriate permits or assistance (for example, construction support or anomaly avoidance), as stipulated in transfer documents.

(d) Notify the receiver not to attempt to disturb, remove, or destroy any found MEC, but to immediately notify local law enforcement representatives who will arrange for the appropriate support.

(e) Be entered in the permanent land records of the civil jurisdiction in which the land is located.

(f) Include disposal documents, to include site-specific data and records that indicate the scope of the MEC response action, and the process used to determine that response action to be adequately protective.

b. *Transfer from Army control to other DOD components.*

(1) Real property known or suspected to contain MEC, excluding property presenting chemical agent hazards, may be transferred from Army control to other DOD Components. Transfers to other DOD Components can only be made to organizations qualified to receive such real property.

(2) Records that accompany the transfer document must identify:

(a) All known impact areas, OB/OD sites, and their associated safety zones (for example, range fans) on the real property.

(b) Any known or suspected MEC that may be present on the real property, by munitions' nomenclature or type, when known, and the known or suspected location. In addition, any records maintained on munitions expended and estimated dud rate by type, quantity, and location shall be transferred.

(c) Any previous explosives or munitions emergencies, range clearance activities or munitions response efforts, conducted within the real property.

*c. Transfers to National Guard Bureau.* Real property known or suspected to contain MEC, excluding property presenting chemical agent hazards, may be transferred to a National Guard unit. In addition to providing the information outlined in paragraph 19–22*b*, the transfer documents must:

(1) Restrict the real property's use to that compatible with the presence of any MEC known or suspected to be present.

(2) Require a munitions response per an approved MRESS before a change of use or further transfer.

### **19–23. Change of use of real property**

Prior to changing the use of Army real property known or suspected to contain MEC to a use that is incompatible with the degree of MEC potentially present; a munitions response per a DDESB-approved MRESS is required.

## **Chapter 20 Transportation of Ammunition and Explosives**

### **Section I General Requirements**

#### **20–1. General information**

Shipments of Army explosives and other dangerous articles by military conveyances are governed by AR 385–10, this pamphlet, other referenced military publications, and, outside the United States, host country regulations. In the United States, shipments of military explosives and other dangerous articles are governed by DOT regulations and DTR 4500.9–R. Shipments outside of the United States are governed by host country regulations. In the absence of host country hazardous materials transportation regulations, AR 385–10 and this pamphlet will apply to movements of ammunition and explosives.

#### **20–2. Certification of personnel involved with transportation**

All personnel involved with the classification, preparation of items and/or bills of lading, inspection of vehicles and/or shipments, loading or unloading of carriers, driving, or other duties that directly involve the transportation of ammunition or explosives require training and certification in accordance with DTR 4500.9–R and DOT regulations.

#### **20–3. Hazard classification**

*a.* All ammunition and explosive items require a final or interim hazard classification before shipment. The JHCS shall be used as the source for all DOD final hazard classified items.

*b.* Items without final hazard classification must have an interim hazard classification (IHC) assigned before shipment. The developing ACOM, ASCC, or DRU normally issues an interim classification for that item. The interim classification must be signed only by personnel delegated that authority, per TB 700–2 (see <http://www.ddesb.pentagon.mil>). It may also be issued by USATCES as necessary. A copy of all IHCs must be forwarded to the DDESB. IHCs are valid for transportation for up to one year. IHC renewals for transportation require a request for justification for the continued need. Army IHCs are valid for storage indefinitely worldwide. The following is a list of items requiring an IHC before shipment:

(1) Developmental or test items.

(2) Standard items that have been modified.

(3) Ammunition items of foreign manufacture. (See chap 10 for rules governing captured ammunition.)

#### **20–4. Preparation for shipment**

*a.* Once a requirement for an ammunition shipment is identified, a person trained and certified in accordance with DTR 4500.9–R verifies the hazard classification of the explosives item. This person then provides the following minimum information to the transportation officer:

(1) Proper shipping name.

(2) DOT hazard class.

- (3) DOT labels required.
- (4) DOT markings required.
- (5) DOD hazard class and division.
- (6) DOD storage compatibility group.
- (7) United Nations Organization (UNO) number.

*b.* TB 9-1300-385 will be checked for suspensions/restrictions before offering an ammunition/explosive item for shipment.

*c.* Transportation on roads that are uncontrolled by DOD, as defined in DTR 4500.9-R, chapter 204, shall comply with all packaging, marking, labeling, loading, placarding, and certification requirements of local, state, Federal (49 CFR), host country and DOD publications.

#### **20-5. Compatibility of explosives in transportation**

*a.* The Army storage compatibility grouping authorized in table 7-1 differs from compatibility authorized in a transportation mode. Army storage compatibility allows additional combinations of compatibility grouping by authorizing the use of 'Z' storage criteria. The DOT Highway, Rail and Sea compatibility tables do not utilize 'Z' compatibility. Additionally, the Army storage compatibility chart allows compatibility group N to be stored with compatibility groups B, F, and G. These combinations are not authorized for transportation by the DOT.

*b.* When ammunition in either commercial or military conveyance is to be transported along or across roads accessible to the public, DOT compatibility rules shall apply.

*c.* When ammunition is transported along or across roads that are not accessible to the public or roads that are clearly posted as prohibited to the public, ammunition may be transported according to the Army storage compatibility chart (see table 7-2). Blasting caps or detonators will not be transported with high explosives unless they are packed in an MK 663 MOD 0 container or equivalent. Additionally, table 7-2, note 7 is not authorized for transportation.

*d.* When ammunition is transported in the training area on the installation, by troops on a training exercise using tactical vehicles, the vehicles may transport a mix of ammunition similar to that the vehicles would carry in combat, provided the vehicles do not cross or move along a route accessible to the general public.

*e.* Incompatible loads may be transported on public roads during times of war, contingency operations (not contingency exercises) or declared national emergencies when DOT Exemption 3498 has been invoked and the shipper complies with all provisions of that exemption. Section II Section II Part Four Motor Vehicles

#### **20-6. Vehicle general safety requirements**

*a.* Government-owned motor vehicles used to transport hazardous materials must be inspected frequently by a qualified person to see that mechanical condition and safety devices are in good working order. The periodic inspections of such vehicles will be documented using a DD Form 626 (Motor Vehicle Inspection), or a similar local form.

*b.* Operators must conduct a daily inspection to determine that:

(1) Fire extinguishers are serviceable and of proper (10-BC or greater) rating. Extinguishers must have an intact inspection seal or a gage to verify that the extinguisher is full.

(2) Electric wiring is in good condition and properly attached.

(3) Fuel tank and piping are secure and not leaking.

(4) Brakes, steering, and other equipment are in good condition.

(5) The exhaust system is not exposed to accumulations of grease, oil, gasoline, or other fuels and has ample clearance from fuel lines and other combustible materials.

*c.* All lifting devices on vehicles used in explosives operations will have a serviceable mechanism designed to prevent the sudden dropping of the load if power fails.

*d.* All ammunition or explosives loaded on vehicles will be secure and stable before movement. Additionally, ammunition or explosives will be blocked and braced in accordance with approved drawings.

*e.* Placarding of explosives-laden vehicles gives firefighters an idea of the hazards that a vehicle contains. All vehicles hauling ammunition and/or explosives for the Army within the United States require proper DOT placards for off post movement. Host country requirements for placarding will be followed outside the United States. Ammunition or explosives shipments that remain on post may be placarded with the DOT placards, host country bilingual placards (outside the United States) or with the fire symbols detailed in chapter 6. If the Army installation is an open post, DOT placards will be used in the United States.

#### **20-7. Inbound motor shipment of ammunition and explosives**

*a.* Inbound motor vehicles loaded with explosives, ammunition, or other hazardous material will be inspected by a competent person at a designated inspection station in accordance with DTR 4500.9-R using DD Form 626. The inspection station will be far from hazardous and populated areas.

b. When inspection reveals that an incoming tractor or trailer is in an unsatisfactory condition, the risk associated with the defect will be assessed.

(1) Under no circumstances will a tractor or trailer be allowed into the ammunition area with a defect which could endanger the area or the load.

(2) When a commercial truck is not allowed to enter the ammunition area, consider unloading it at the truck inspection station. If no other option is available, the tractor will be disconnected from the trailer and the tractor will be sent off-post for repairs. In this case, the installation will provide security for the trailer.

(3) The drivers or repairmen hired by the drivers will repair the trailer. No repairs which use a flame or spark producing device will be made to an explosives-laden trailer.

(4) In all cases, defective equipment on inbound shipments will be noted on the DD Form 626 and a copy provided to the transportation officer.

(5) At no time will an explosives-laden truck known to be defective be allowed to leave an Army installation.

c. When explosives-laden vehicles cannot be dispatched to unloading points immediately, they must be moved to a holding yard or area. The holding yard or area must be sited in accordance with the provisions of table 8-6 of this pamphlet.

## **20-8. Outbound motor shipment of ammunition and explosives**

a. All motor vehicles which will be carrying DOT Class 1.1, 1.2 or 1.3 explosives must be inspected using a DD Form 626. Deficient equipment will not be used.

b. When a commercial vehicle fails an inspection using a DD Form 626, a copy of the inspection will be provided to the transportation officer and the procedures in DTR 4500.9-R will be followed.

c. Loading methods prescribed by Army Materiel Command (AMC) 19-48 series drawings will be followed for the loading and bracing of motor vehicle shipments of military ammunition and explosives. The packages will be placed in position without excessive or violent force.

d. All Government trucks transporting any DOT class of explosives (both on post and off post) will be equipped with two portable fire extinguishers rated class 10BC or greater. It is recommended that these two fire extinguishers be rated 2A:10B:C to enable users to fight a class "A" fire. One must be CO<sub>2</sub> or dry chemical, if chemical munitions are being transported. Commercial trucks transporting explosives for the Army are required to have only one 10BC or greater rated fire extinguisher. Crews loading and unloading vehicles carrying or about to carry ammunition or explosives must have two 10BC or greater fire extinguishers available as required by chapter 6.

e. Before motor vehicles loaded with ammunition and/or explosives leave an installation, drivers will be given hazardous materials response information. Commercial drivers will have the bills of lading annotated with the appropriate guide number from DOT Emergency Response Guidebook (ERG). Military drivers will use the DD Form 836 for hazardous materials information dissemination.

f. See AR 190-11 for instructions on security of vehicles carrying ammunition and/or explosives.

## **20-9. Secure holding area for explosive shipments**

Installations with a secure holding area capability as identified in DTR 4500.9-R may grant safe haven to explosive shipments when requested by Surface Deployment and Distribution Command (SDDC) through the installation commander. Drivers who request secure holding area use from the guard at the installation gate will be advised to contact their company and have the company request safe haven through SDDC. If approval to use the secure holding area is granted, the driver is still accountable for the security of the load. Installations may approve use of secure holding areas in other situations at the discretion of the installation commander. If approval is not granted, installations will consider allowing an explosives-laden truck to rest at a secure area that meets QD criteria, but installations will not assume security responsibility for the shipment unless directed to do so by the installation commander.

## **20-10. On-post explosives movements**

a. Cargo-type trucks and truck-tractor drawn semi-trailer vans are best for transporting ammunition or explosives.

b. Equipment used for transporting ammunition or explosives must meet the following minimum requirements:

(1) Special precautions must be taken to avoid automotive exhausts igniting material.

(2) The lighting system must be in good working condition. Batteries and wiring will be located so that they will not come into contact with containers of explosives, ammunition, or other hazardous material. If exposed explosives or flammable vapors are encountered in a vehicle, only approved portable lights are permitted (listed by a nationally recognized organization for the specific hazardous locations defined by NFPA 70).

(3) The interior of the cargo body will have all exposed ferrous metal covered with non-sparking material when transporting ammunition or explosives not packaged for shipment in accordance with DOT specifications.

(4) Open-body vehicles, other than flatbed trailer-types used to transport large items such as rockets or missiles must have sides that are strongly constructed and securely fastened so that the items are safely retained.

(5) When a top is required, it will be of a noncombustible or flame-proof material. Tarpaulins used for covering explosives will be secured by rope or tie downs. Nails will not be used to fasten protective tarpaulins.

c. Ammunition will be blocked and braced or secured with suitable tie-down straps to prevent movement.

## **20–11. Passengers in or on Government vehicles transporting explosives**

a. Except as noted below, passengers shall not ride in vehicles transporting ammunition or explosives.

b. Under certain conditions, as approved in a standard operating procedure, the minimum essential personnel and limited quantities of HDs 1.2.2, 1.3 and 1.4 ammunition and/or explosives may be transported together in the cargo portion of vehicles. Examples are vehicles used by the military police (MP) in providing security or by EOD personnel performing their mission. These conditions are as follows:

(1) Explosives are packed separately from other items and packed in closed, clearly identified metal or wooden containers properly secured or sandbagged in the vehicle body to prevent movement.

(2) Seats are provided for all passengers.

(3) Smoking is not allowed in the vehicle.

(4) The vehicle cannot be left unattended.

c. Troops and ammunition may be transported in the same vehicle during training exercises when the vehicle is the prime mover for a weapon system engaged in the tactical portion of the exercise, troops being transported are assigned to the weapon system being moved, the vehicle is organic to the unit, and the vehicles remain on the training range. The only exception will be for HD 1.4 ammunition when it is necessary to travel between training ranges (on post or off post) and then conditions in paragraph e below will apply. Transport between ranges (on post or off post) of all other ammunition and explosives will be in accordance with paragraph 20–8 above.

d. Mission essential passengers may ride in the passenger compartments of vehicles transporting explosives if they can be safely seated.

e. Explosives will not be transported in a passenger compartment of a vehicle except in cases involving limited quantities (no more than two full outer-packs of small arms ammunition with non-explosive bullets). The small arms ammunition must be in closed containers which are properly secured in the vehicle, and seats must be available for all personnel. Using privately owned vehicles for such purposes is prohibited, except for the Reserve Officer Training Corps (ROTC) and Marksmanship Programs when a government-owned vehicle is not available. It is permissible to transport limited quantities of HD 1.4 small arms ammunition in the trunk of sedan-type government-owned vehicles or in cargo compartments of government-owned van type vehicles.

## **Section II**

### **Rail, Air, and Water Transport**

#### **20–12. Railroad transportation**

a. *Railcar inspection.*

(1) A car must not be loaded with any DOT Class 1.1 or 1.2 explosives unless it has been thoroughly inspected by a qualified individual, employed by the railroad. This individual must certify that the railcar conforms to the requirements established in DTR 4500.9–R.

(2) Shipments of DOT Class 1.3 explosives may be loaded in a closed car or container car which is in good condition and which sparks cannot enter.

(3) Selections of cars for shipment of DOT classes 1.4, 1.5, or 1.6 will be done in accordance with 49 CFR selection criteria for 1.4 (Sec 174.115).

b. *Transportation of hazardous materials.* In addition to the requirements of other parts of this section, the following rules will be followed:

(1) When cars containing explosives or other hazardous materials are received at the installation or held in yards, precautions must be taken to prevent accidents, particularly at night. These precautions must include provisions for quickly removing and isolating the cars in case of fire.

(2) Cars loaded with hazardous materials must be properly loaded and placarded before being offered for transportation. The carrying of hazardous materials on locomotives or other self-propelled rail vehicles is prohibited.

(3) Before cars are moved by a locomotive, the air brake hose will be coupled and tested to assure that the air brakes are in proper working condition and the car doors will be closed.

(4) Empty cars will not be removed from warehouses, magazines, building, or loading docks until all warning placards have been removed.

(5) Special care must be taken to avoid rough handling of cars. Cars must not be cut off while in motion and must be coupled carefully to avoid unnecessary shocks. Other cars must not be cut off and allowed to strike a car containing explosives. Cars must be so placed in yards or on sidings that they will be subject to a minimum of handling and can be readily removed from danger of fire. Such cars must not be placed under bridges; in or alongside passenger sheds of a station; and, where avoidable, engines on parallel tracks will not be allowed to stand opposite or near them.

(6) “Dropping,” “humping,” “kicking,” or the use of the flying switch is prohibited.



(7) Adequate measures such as guarding, patrolling, and safety inspecting must be provided at all times. All such activities will be under positive administrative controls.

(8) Fire symbols or DOT placards will be placed on each railroad car while transporting ammunition or explosives within an installation to provide quick identification of the potential hazard if fire breaks out.

*c. Car inspection.* Car inspections will be conducted in accordance with DTR 4500.9-R.

*d. Car certificates.* Car certificates will be used in accordance with DTR 4500.9-R.

*e. Leaking packages.* Constant alertness must be maintained to detect hazardous materials leaking from faulty packages either by sight or through characteristic odors. Leaking packages will be removed from cases and repaired. If artificial light is necessary, only electric lights approved for the hazard involved will be used. All unnecessary movement of a leaking package discovered in transit must cease until the unsafe condition is remedied.

*f. Car loading of items containing ammunition and explosives.* Loading methods prescribed by AMC 19-48 series drawings (AMC Drawing 19-48-75-5 contains a list of AMC drawings and ordering instructions.) will be followed for the loading and bracing of railway car shipments of military ammunition and explosives. If no drawing is available or yet developed, Bureau of Explosives (BOE) Pamphlets 6 and 6C will be used. The packages will be placed in position without excessive or violent force.

*g. Tools for loading and unloading railcars.* With reasonable care, steel tools may be used inside cars if explosives likely to ignite are not exposed. When explosives subject to initiation are exposed, sparkproof-tools will be used.

*h. Sealing cars containing ammunition and explosives.* In addition to any other seals that may be used, cars containing ammunition or explosives will be secured. A cable seal lock plus an upper rail lock will be used to secure car doors. Serial numbers of seals will be placed on the Government bill of lading (GBL).

*i. Inspection of cars before unloading.*

(1) A qualified person must inspect railcars containing ammunition and explosives entering an installation. This inspection includes examining the outside and underside of each car for damage, to detect unauthorized and suspicious items, and to check the correctness of individual car numbers and seal numbers against bills of lading. When the probability of sabotage is remote, such inspections may be accomplished from ground level without using an inspection pit to discover unsafe structural mechanical deficiencies of the car. During periods of emergency when sabotage may be attempted, and also to aid in the rapid inspection and movement of cars, an inspection pit will be provided.

(2) Cars of ammunition or explosives on which foreign and suspicious articles have been secreted or attached outside or underneath the car, or cars which show a defect that might affect the installation or contents of the car, will be removed to the suspect siding for additional inspection.

(3) Cars which satisfactorily pass the inspection outlined above may be considered reasonably safe, but care must be exercised in breaking car seals and opening car doors because of possible damage or shifting lading, leaking containers, and so forth. When the QD standards for classification yards are met, cars may be opened for inspection in the classification yard. Otherwise, interior inspection will be accomplished after the cars have been spotted at the unloading point.

*j. Inspection of cars after unloading.* Cars in which ammunition or explosives are received will be inspected after unloading to see that they are clean and free from loose explosives or other flammable materials and that the placards and car certificates are removed. Explosives sweepings must be destroyed.

*k. Damaged shipment.* Any shipment received in a damaged condition because of inadequate or improper blocking and bracing or failure to load in accordance with appropriate AMC 19-48 series drawings will be reported on DD Form 361 (Transportation Discrepancy Report) in accordance with DTR 4500.9-R-Part II, Cargo Movement. If the damage was due to improper preservation, packaging, or packing, a supply discrepancy report will be prepared in accordance with AR 735-11-2 and AR 12-12.

*l. Marking railcars with blue flags or signals.* Blue flags or signals will be placed at both ends of a car or group of cars when personnel are working in, on, or under the cars. Cars marked in this manner will not be coupled to or moved. The supervisor or foreman in charge of the personnel loading or unloading the cars will place and remove the blue flag or signal. Train crews will be informed of the use of blue flags or signals. Exceptions are as follows:

(1) Flags are not required when flat cars are involved and the presence of a working party is clearly evident.

(2) Flags or signals may be omitted from the end of a car located against or toward a dead end spur. This also applies to a loading ramp where no other railcars can approach from that direction.

*m. Looping railroad lines.* Railroad lines serving explosives areas will be looped to give at least two ways to exit. Looping of railroad lines may not be required if a local hazard analysis indicates operations can be conducted safely.

*n. Right-of-way fire hazard.* Grass and brush along railroad right-of-way which present a fire hazard will be controlled.

## **20-13. Air transportation**

Carrying ammunition, explosives, and other hazardous materials on civil aircraft is regulated by the DOT. Criteria for preparing and carrying hazardous materials on military aircraft are contained in TM 38-250, DOT regulations, and AR 95-27.

*a. Military aircraft operating regulations.*

(1) If an aircraft carrying hazardous materials makes a landing, forced or otherwise, and only minor repairs or refueling are necessary, the cargo need not be unloaded. Repairs or refueling will be accomplished at a location separated from dissimilar explosives and other aircraft by the appropriate IBD for the cargo aboard. For major repairs, the plane will be unloaded and the cargo stored in accordance with QD requirements. Appropriate protection will be afforded the cargo during inclement weather.

(2) When an explosive laden aircraft is parked in a designated, restricted, and posted explosives parking or loading and unloading area, fire symbols will be posted at all normal approaches to the designated area. Otherwise, fire symbols will be placed at the nose, tail, and each side of the aircraft. Where the height of the aircraft does not readily permit attaching the fire symbols to the aircraft, the fire symbols may be mounted on stands approximately 1.5 meters (5 feet) in height, positioned adjacent to the aircraft where they are visible at long range. At other DOD installations and at non-DOD installations, placarding will be in accordance with the requirements of TM 38-250 and the requirements of the host installation.

*b. Permissible air shipments.* Ammunition and/or explosives that may be shipped by civil air are identified in 49 CFR. Ammunition and/or explosives that may be shipped by military aircraft are identified in TM 38-250.

*c. Loading and unloading aircraft.*

(1) Before an aircraft can be loaded or unloaded with ammunition and/or explosives, it must be electrically grounded so that the resistance to ground does not exceed 10,000 ohms.

(2) When loading or unloading aircraft containing ammunition or explosives, work crews will display placards and fire symbols.

(3) Loading and unloading will be done in accordance with the QD requirements of chapter 8.

(4) All ignition switches must be in the OFF position.

(5) Front and rear wheel will be chocked.

(6) The loadmaster will direct the loading of military aircraft. Nonmilitary aircraft will be loaded to comply with civil air regulations.

(7) At nonmilitary airfields used by US Army flight activities, the host normally provides aircraft rescue and fire protection. If this protection does not meet the standards established in AR 420-1, Army fire department personnel and/or auxiliary firefighters will be used during Army flight activities, including loading and unloading of explosives.

(8) As a minimum, four portable fire extinguishers will be available for firefighting during all loading and unloading of explosives. Recommended extinguishers are as follows:

(a) Two each pressurized water-type extinguishers using Aqueous Film-Forming Foam (AFFF) liquid concentrate, 6 percent (MIL-F-24385); and,

(b) Two each Potassium Bicarbonate Base Dry chemical extinguishers, 13.6 kilograms (30 pounds) capacity.

*d. Damaged shipments.* Air shipments of ammunition or explosives received in a damaged condition or not loaded in accordance with applicable requirements will be reported in accordance with 41 CFR 101 or DTR 4500.9-R Part II Cargo Movement.

*e. Containers.* Containers of explosives in aircraft will not be opened or repaired.

## **20-14. Water transportation**

*a.* Transporting explosives and/or ammunition on waters under US jurisdiction and in vessels engaged in commercial service is regulated by the U.S. Coast Guard (USCG). Shipments overseas will be made in accordance with the regulations of the carrier, the USCG, International Maritime Dangerous Goods Code, or the Department of the Army (See TM 55-607). If the travel route requires passing under any bridges, obtain prior authorization from the responsible agency.

*b.* Damaged shipments or shipments not stowed in accordance with regulations when received will be reported in accordance with DTR 4500.9-R-Part II Cargo Movement. If damage was due to improper preservation, packaging, or packing, a supply discrepancy report will be prepared in accordance with AR 735-11-2.

*c.* Containers of ammunition and explosives will not be opened or repaired on board a vessel.

*d.* Vessels in which ammunition or explosives are received will be inspected after unloading to see that they are clean and free from loose explosives or other flammable materials and that warning placards, and so forth are removed. Explosives sweepings will be destroyed.

## **Chapter 21 Storage and handling of commercial explosives**

### **21-1. Background**

This chapter provides guidance on the storage and handling of commercial explosives on Army installations.

## 21-2. Use

Using commercial explosives, other than for production and Research, Development, Test, & Evaluation (RDTE), is prohibited unless commercial explosives are mission essential and specifically authorized by the installation's ACOM, ASCC or DRU commander (see para 21-3e and f, below). ACOM, ASCC, or DRU approval is not required for the storage of commercial small arms ammunition used by contract security personnel for use in non military weapons provided the ammunition is stored in a properly licensed arms room that is separate from government owned ammunition, and a risk assessment has been performed and approved by the appropriate risk acceptance authority (the arms room shall be licensed in accordance with chapter 5 of this pamphlet). Additional authorizations and guidance for the storage, treatment, and disposal of nondefense toxic and hazardous materials are provided in 10 USC 2692.

## 21-3. Procedures

- a. Obtain approval to use commercial explosives before purchase.
- b. The HD and CG information will be requested and should be received before purchase.
- c. When commercial explosives are received before USATCES assigns HD and CG information, commercial explosives will be stored as HD 1.1, CG L. Small arms ammunition will be stored as HD 1.4, CG S.
- d. The NEW will be calculated based on the weight of the explosive or TNT equivalent, whichever is larger.
- e. Approval request to store or handle commercial explosives will be sent through command channels to the installation's ACOM, ASCC or DRU approving authority.
- f. When the requesting unit is a tenant activity, the request will be sent through the unit's command channels and the host installation's ACOM, ASCC or DRU approving authority must concur with the approval.
- g. The HD and CG will be obtained by providing the following information to Director, USATCES.
  - (1) Documentation of an HD assignment by a competent authority; that is, DOT, BOE, Bureau of Mines (BOM), or foreign government; or reports of HD testing or function testing accomplished by a competent authority; or results of small scale laboratory tests conducted by a competent authority.
  - (2) Complete item nomenclature.
  - (3) Part number, drawing number, or something that uniquely identifies the item in its storage configuration.
  - (4) Explosives or hazardous composition and weight. A chart or listing of hazardous materials with their weights is preferred.
  - (5) Packaging data.
  - (6) Number of independent safety features if the item is a fuze, contains a fuze, or has features similar to a fuze.
  - (7) Any other available information that may reflect the function or the effects of the explosive.
  - (8) A point of contact and telephone number for the responsible Army organization.
- h. To receive inspection interval codes and inspection procedures, forward information required in paragraph 21-3g(1) - (8) above, to Commander, US Army Joint Munitions & Lethality Life Cycle Management Command.

## 21-4. Commercial dynamite

a. Dynamite is sensitive to heat and shock. Containers suspected of containing sticks of dynamite that may exhibit signs of exudation or crystallization (generally, these boxes have an oily appearance) will be removed and inspected by EOD or trained personnel. Individual sticks having exudation or crystallization will be disposed or destroyed by burning or detonation immediately. The remainder may be repacked and returned to storage. Empty containers that have been used for dynamite will be destroyed by burning. Oily stains of nitroglycerin on magazine floors will be carefully scrubbed up with a mixture of solution A (Sodium sulfide - 9 parts by weight and water - 30 parts by weight.) and Solution B (Denatured ethyl alcohol - 70 parts by weight and acetone - 20 parts by weight) after the magazine has been emptied of all other explosives. Immediately before decontaminating the nitroglycerin, combine the solutions. If the solutions are mixed and then stored, the potency diminishes in storage. Limit the use of this mixture to very small quantities. Ensure the oily film that adheres to surfaces has been removed with non sparking tools, sponges or absorbed in wood pulp or sawdust. Residue from cleanup operation shall be destroyed by burning. Operators using this solution shall wear rubber gloves and face shields.

b. Store cases of commercial dynamite initially right side up, so cartridges will lie flat. However, to reduce the possibility of exudation of nitroglycerin from the cartridges of straight dynamite 60 percent or over in strength, it will be necessary to turn the cases, based on average storage temperature ( see table 21-1).

c. The first turning will leave the cases bottom side up, with the cartridges still in a horizontal position. The second turn of the boxes will place the boxes right-side-up. Each turn of the boxes will be 180 degrees. Frozen dynamite will not be turned. With the exception of straight dynamite, 60 percent and over in nitroglycerin strength, other types of dynamite-ammonia, ammonia-gelatin, and gelatin need not be turned in storage. However, yearly, at the conclusion of the year's warmest season, a representative sample will be selected and the containers examined for evidence of nitroglycerin on the exterior of the cartridge and/or packing materials.

**Table 21-1**  
**Turning of commercial dynamite**

<b>Average storage temperature</b>	<b>Interval between turnings</b>
Below 30 degrees (F)	Do not turn
30 to 60 degrees (F)	Every 4 months
60 to 75 degrees (F)	Every 3 months
Over 75 degrees (F)	Every 6 weeks

## **Appendix A References**

### **Section I Required Publications**

#### **AR 190-11**

Physical Security of Arms, Ammunition and Explosives (Cited in paras 8-3a, 20-8f.)

#### **AR 190-12**

Military Working Dog Program (Cited in paras 2-14, 13-1a, 13-2.)

#### **AR 385-10**

Army Safety Program (Cited in paras 1-1, 1-2a, 1-4, 1-5, 1-6b(18), 1-10, 2-4, 4-1g, 18-5a, 19-7, 19-12b(7), 20-1, and para D-1c.)

#### **AR 385-63**

Range Safety (Cited in paras 4-1b(1), 4-1a(11).)

#### **AR 420-1**

Army Facilities Management (Cited in paras 3-15, 6-1f, 6-1c, 6-7, 6-18a, 16-24, 20-13c.)

#### **AR 690-950**

Career Management (Cited in para 1-6.)

#### **AR 75-1**

Malfunctions Involving Ammunition and Explosives (RCS-CSGLD-1961 (M1)) (Cited in para 2-1c.)

#### **AR 75-15**

Policy for Explosive Ordnance Disposal (Cited in para 3-7c.)

#### **DA Pam 40-501**

Hearing and Conservation Program (Cited in paras 13-1a, 13-2, 15-3b(8).)

#### **DA Pam 385-10**

Army Safety Program (Cited in paras 2-2, 2-4, 17-19g.)

#### **DA Pam 385-30**

Mishap Risk Management (Cited in paras 2-2, 6-19d, 8-28a, 14-3b.)

#### **DA Pam 385-61**

Toxic Army Chemical Agent Safety Standards (Cited in paras 3-9f(3), 3-9a(1), 17-19g.)

#### **DA Pam 385-63**

Range Safety (Cited in paras 1-6, 1-12, 19-2c(1).)

#### **DA Pam 385-65**

Explosive and Chemical Site Plan Development and Submission. See table 12-4. (Cited in paras 4-2, 8-2c.)

#### **DA Pam 40-501**

Standards of Medical Fitness (Cited in para 15-3b(8).)

#### **DOD 5100.76-M**

Physical Security of Sensitive Conventional Arms, Ammunition, and Explosives (Cited in para 13-1d(6).)

#### **DOD 4160.21-M-1**

Defense Demilitarization Manual (Cited in para 14-15b.)

#### **DOD 6055.16**

Explosive Safety Management Program (Cited in para 1-5b(2).)

**DODD C-3325.1**

Foreign Material Program (Cited in para 2-8e.)

**DODD 6055.9E**

Explosives Safety Management and the DOD Explosives Safety Board (Cited in paras 1-1, 1-5b(2), 18-6b.)

**DODI 4140.62**

Material Potentially Presenting an Explosive Hazard (MPPEH) (Cited in paras 3-6f, 14-15b, 19-6f, 19-7e, 19-7a.)

**DODM 6055.09-M**

DOD Ammunition and Explosives Safety Standards. (Cited in paras 1-1, 1-5b(2), 10-9b(3), 12-4, 19-1.)

**DTR 4500.9-R Part II**

Cargo Movement. See table 8-6. (Cited in para 20-7c.)

**ANSI Safety Code A14.3**

American National Standards for Ladders-Fixed-Safety Requirements. Available at <http://webstore.ansi.org>. (Cited in para 16-9.)

**ANSI Safety Code A156.3**

American national Standards for Exit Devices. Available at <http://webstore.ansi.org>. (Cited in para 16-7.)

**ASHRAE Standard 15**

Safety Standard for Refrigeration Systems. Available at <http://www.ashrae.org/catalog>. (Cited in para 16-18.)

**ASTM F2413**

Standard for Performance Requirements for Foot Protection. Available at <http://www.astm.org/Standards/F2413.htm>. (Cited in para 7-10d(2)(a).)

**TB 700-2**

Department of Defense Ammunition and Explosives Hazard Classification Procedures. See <http://www.ddesb.pentagon.mil>. (Cited in paras 7-1, 20-3, 19-11i.)

**FM 55-450-2**

Army Helicopter Internal Load Operations (Cited in para 17-10n.)

**FM 4-02.285 (FM 8-285)**

Multiservice Tactics, Techniques, and Procedures for Treatment of Chemical Agent Casualties and Conventional Military Chemical Injuries (Cited in para 3-12.)

**International Standards Organization (ISO) 1813**

Belt drives—V-ribbed belts, joined V-belts and V-belts including section belts and hexagonal belts-Electrical conductivity of antistatic belts: Characteristics and methods of test (This publication may be obtained from the American National Standard Institute, 1430 Broadway, ATTN: Sales Dept, New York, NY 10018.) See appendix C-6b. (Cited in para 17-15.)

**Joint Hazard Classification System (JHCS)**

Official DOD database of final hazard classification data for the military services' ammunition and explosives maintained by USATCES (Cited in paras 8-6, 19-12a(6), 20-3a.)

**MIL-HDBK 419**

Grounding, Bonding, and Shielding for Electronic Equipment and Facilities (This publication may be obtained from the Commanding Officer, Naval Publications and Forms Center, 5801 Tabor Avenue, Philadelphia, PA 19120.) See appendix B-4a. (Cited in para 17-15.)

**MIL-STD-1474C**

Noise Limits (This publication may be obtained from the Naval Publications and Forms Center, Standardization Documents Order Desk, Bldg 4D, 700 Robins Avenue, Philadelphia, PA 19111-5094.) (Cited in para 8-28b.)

**MIL-STD-398**

Shields, Operational for Ammunition Operations, Criteria for Design and Tests for Acceptance. See table 8-27. (Cited in paras 8-28a(2), 14-3a.)

**MIL-T-21869**

Truck, Lift, Fork, Electric, Solid Tires, 2000 - 4000 - 6000 Pound Capacity, General Specification. See table 17-1. (Cited in paras (Cited in paras 17-10, 17-13, 17-14).)

**NFPA) Standard 13**

Standard for the Installation of Sprinkler Systems (This publication may be obtained from the National Fire Protection Association, 1 Batterymarch Park, Quincy, MA 02269-91 (Cited in para 16-24.)

**NFPA Standard 16**

Standard for the Installation of Foam-Water Sprinkler and Foam-Water Spray Systems (Cited in para 16-24.) (This publication is available at the National Fire Protection Association, 1 Batterymarch Park, Quincy, MA 02269-9101.)

**NFPA Standard 30**

Flammable and combustible Liquids Code (This publication may be obtained from the National Fire Protection Association, 1 Batterymarch Park, Quincy, MA 02269-9101.) See tables 8-6, 12-5, and 12-2. (Cited in paras , 6-8f.)

**NFPA Standard 31**

Standard for the Installation of Oil-Burning Equipment (This publication may be obtained from the National Fire Protection Association, 1 Batterymarch Park, Quincy, MA 02269-9101.) See table 8-6. (Cited in para 8-17.)

**NFPA Standard 33**

Standard for Spray Application Using Flammable and Combustible Liquids (Cited in paras 14-8e, 14-8a, 14-10d, 14-11a, 17-10k, 19-9a.)

**NFPA Standard 50**

Standard for Bulk Oxygen Systems at Consumer Sites. See table 12-7. (Cited in para 12-5.)

**NFPA Standard 58**

Storage and Handling of Liquefied Petroleum Gases (This publication may be obtained from the National Fire Protection Association, 1 Batterymarch Park, Quincy, MA 02269-9101.) (Cited in para 2-17d.)

**NFPA Standard 70**

National Electrical Code (This publication may be obtained from the National Fire Protection Association, 1 Batterymarch Park, Quincy, MA 02269-9101.) (Cited in paras 16-22, 17-1, 17-2f, 17-2b, 17-3a, 17-5a, 17-10c, 17-10b, 17-13d, 17-14g(1)(a).)

**NFPA Standard 77**

Recommended Practice on Static Electricity (Cited in paras 12-10k, 14-8a, 14-9a.)

**NFPA Standard 80**

Standards for Fire Doors and Other Opening Protectives (This publication may be obtained from the National Fire Protection Association, 1 Batterymarch Park, Quincy, MA 02269-9101.) (Cited in paras 16-4, 16-7.)

**NFPA Standard 90A and Standard 90B**

90A—Standard for the Installation of Air-Conditioning and Ventilating Systems, 90B—Standard for the Installation of Warm Air Heating and Air-Conditioning Systems (Cited in paras , 16-21d.)

**NFPA Standard 101**

Life Safety Code(r) (2006) (This publication may be obtained from the National Fire Protection Association, 1 Batterymarch Park, Quincy, MA 02269-9101.) (Cited in paras 16-5, 16-7.)

**NFPA Standard 251**

Standard Methods of Tests of Fire Resistance of Building Construction and Material. See table 12-5. (Cited in para 12-5.)

**NFPA Standard 430**

Code for the Storage of Liquid and Solid Oxidizers. See table's 12-2, 12-6. (Cited in para 12-5.)

**NFPA Standard 505**

Fire and Safety Standards for Powered Industrial Trucks, Including Type Designations, Areas of Use, Conversions, Maintenance, and Operations (This publication may be obtained from the National Fire Protection Association, 1 Batterymarch Park, Quincy, MA 02269-9101.) (Cited in para 2-17b(6).)

**NFPA Standard 780**

Standard for the Installation of Lightning Protection Systems. See table 17-5 and appendix D-2a. (Cited in paras 17-13c, 17-14g(1)(a), 17-22, 17-28g.)

**NFPA Standard 1123**

Fireworks Displays (This publication may be obtained from the National Fire Protection Association, 1 Batterymarch Park, Quincy, MA 02269-9101.) (Cited in para 2-12d.)

**TB 43-0142**

Safety Inspection and Testing of Lifting Devices. See table 17-1. (Cited in para 17-10i.)

**TB 9-1300-385**

Munitions Restricted or Suspended (Cited in para 7-4.)

**TB 43-0142**

Safety Inspection and Testing of Lifting Devices (Cited in para 6-10.)

**TM 3-250**

Storage, Shipment, Handling, and Disposal of Chemical Agents and Hazardous Chemicals (Cited in para 3-14.)

**TM 5-811-1**

Electric Power Supply and Distribution (Cited in para 17-19f.)

**TM 5-811-3**

Electrical Design, Lightning and Static Electricity Protection (Cited in para 17-19f.)

**TM 5-811-7**

Electrical Design, Cathodic Protection (Cited in para 17-19f.)

**TM 5-855-1**

Design and Analysis of Hardened Structures to Conventional Weapons Effects (Cited in para 19-6a(2).)

**TM 5-1300**

Structures to Resist the Effects of Accidental Explosions. See table 8-31. (Cited in paras 8-5, 8-11, 14-2f, 16-1, 16-13b(3), 16-28e.)

**TM 9-1300-250**

Ammunition and Explosive Standards (Cited in paras 2-4, 14-5b.)

**TM 38-250**

Preparing Hazardous Materials for Military Air Shipments (Cited in paras , 20-13.)

**TM 43-0001-47**

Army Equipment Data Sheets: Ammunition Peculiar Equipment (Cited in paras 14-5b, 14-9d.)

**UFC 3-260-01**

Airfield and Heliport Planning and Design (Cited in para 8-32d(3).)

**UFC 3-600-01**

Fire Protection Engineering for Facilities (Cited in para 6-11.)



**10 USC 2692**

Storage, treatment, and disposal of nondefense toxic and hazardous materials (Cited in para 1–5a(5).)

**29 CFR 1910**

Occupational Safety and Health Standards See table's 12–2, 12–5, 12–7 (Cited in paras 6–6, 6–8f, 6–8d, 14–8a, 14–9, 14–11a.) (This publication may be obtained from the Superintendent of Documents, Government Printing Office, Washington, DC 20402.)

**40 CFR 264 through 266**

Protection of Environment (Cited in paras 15–4b, 18–1, 18–2b, 18–3c, 18–3a, 18–5.)

**49 CFR 173 through 177**

Transportation. (Cited in paras 13–1d, 20–12a, 20–13b.)

**Section II**

**Related Publications**

A related publication is a source of additional information. The user does not have to read a related publication to understand this regulation.

**AR 75–14**

Interservice Responsibilities for Explosives Ordnance Disposal

**AR 95–27**

Operational Procedures for Aircraft Carrying Hazardous Materials

**AR 405–80**

Management of Title and Granting Use of Real Estate

**AR 710–2**

Supply Policy Below the National Level

**AR 735–11–2**

Reporting of Supply Discrepancies

**DA Pam 190–12**

Military Working Dog Program

**DA Pam 385–40**

Army Accident Investigation and Reporting

**DODD 4715.11**

Environmental and Explosives Safety Management on Operational Ranges Within the United States

**DODD 4715.12**

Environmental and Explosives Safety Management on Operational Ranges Outside the United States

**40 CFR SubpartM**

Military Munitions Rule

**AMXTH–TE–CR 86096**

Testing to Determine the Relationship Between Explosive Contaminated Sludge Components and Reactivity

**CEHNC–ED–CS–S–97–3**

On-Site Demolition Container for Unexploded Ordnance

**DDESB Technical paper Number 10**

Methodology for Chemical Hazard Prediction

**DDESB Technical Paper Number 13**

Prediction of Building Debris for Quantity-Distance Siting

**DDESB Technical Paper Number 15**

Approved Protective Construction

**EPCRA Sections 302–312, Environmental Protection Agency (EPA)**

The Emergency Planning and Community Right-to-Know Act (EPCRA)

**HNC–ED–CS–S–97–7**

Buried Explosion Module (BEM): A Method for Determining the Effects of Detonation of a Buried Munitions

**HNC–ED–CS–S–98–2**

Method for Calculating Range to No More Than One Hazardous Fragment per 600 Square Feet

**HNC–ED–CS–S–98–7**

Use of Sandbags for Mitigation of Fragmentation and Blast Effects Due to Intentional Detonation of Munitions

**HNC–ED–CS–S–98–8**

Miniature Open Front Barricade (MOFB)

**HNC–ED–CS–S–99–1**

Open Front and Enclosed Barricades (OFB and EB)

**HNC–ED–CS–S–00–3**

Use of Water for Mitigation of Fragmentation and Blast Effects Due to Intentional Detonation of Munitions

**MIL–F–24385**

Fire Extinguishing Agent, Aqueous Film-Forming Form, (AFFF) Liquid Concentrate, for Fresh and Seawater

**Naval Facilities Engineering Service Center (NFESC) 99220001–99220012**

High Performance Magazine Definitive Drawings, <http://www.nfesc.navy.mil/index.html>

**Occupational Safety & Health Administration (OSHA)**

(Available at <http://www.osha.gov/>.)

**SC 4925–95–CL–A03**

Supply Catalog, General Support (GS) Maintenance, Special Tools and Equipment

**SFIM–AEC–ET–CR–97015**

Follow-On Reactivity Study of Primary Explosives in Soil

**SFIM–AEC–ET–CR–95083**

Composting of Nitrocellulose Fines -Hazards Analysis

**TM 55–607**

Loading and Stowage of Military Ammunition and Explosives Aboard Break-bulk Merchant Ships

**UFC 3–600–02**

Operations and Maintenance: Inspection, Testing, and Maintenance of Fire Protection Systems <http://www.hnd.usace.army.mil/techinfo/UFC/UFC%203–600–02.PDF>

**USAEC Report SFIM–AEC–ET–CR–97015**

Follow-On Reactivity Study of Primary Explosives in Soil, May 1997

**USATCES–P 385–02**

Site and General Construction Plan Developer's Guide

**U.S. Army Corps of Engineers Guide Specification CEGS–08850**

Fragment Retention Films (July 1992)

**U.S. Army Corps of Engineers Pamphlet EP 1110–345–2**

Index of Design Drawings for Military Construction

**U.S. Army Corps of Engineers publication HNDED-CS-S-95-01**  
Guide for Evaluating Blast Resistance of Non-Standard Magazines

**U.S. Department of the Interior, Bureau of Mines, Washington D.C., Bureau of Mines Report of Investigation 5707**

Research on the Hazards Associated with the Production and Handling of Liquid Hydrogen, (1961)

### **Section III**

#### **Prescribed Forms**

This section contains no entries.

### **Section IV**

#### **Referenced Forms**

Unless otherwise indicated, DA forms are available on the Army Publishing Directorate (APD) Web site (<http://www.apd.army.mil>); DD forms are available on the Office of the Secretary of Defense (OSD) Web site (<http://www.dtic.mil/whs/directives/infomgt/forms/formsprogram.htm>); and Standard Forms (SF) are available on the U.S. General Services Administration (GSA) Web site (<http://www.gsa.gov>.)

#### **DA Form 2028**

Recommended Changes to Publications and Blank Forms

#### **DA Form 2609**

Historical Property Catalog

#### **DA Form 3020-R**

Magazine Data Card

#### **DA Form 5383**

Hot-Work Permit

#### **DA Form 7632**

Certificate of Risk Acceptance (CORA).

#### **DD Form 361**

Transportation Discrepancy Report

#### **DD Form 626**

Motor Vehicle Inspection

#### **DD Form 836**

Dangerous Goods Shipping Paper/Declaration And Emergency Response Information For Hazardous Materials Transported By Government Vehicles/Containers Or Vessel

#### **DD Form 1575**

Suspended Tag – Materiel

## **Appendix B**

### **Earth Electrode Subsystem Test and Inspection**

#### **B-1. Introduction**

This appendix provides criteria and procedures for conducting both visual inspection and electrical testing of earth electrode subsystems.

#### **B-2. Visual inspection criteria**

The earth electrode subsystem will be visually inspected only when or where the subsystem is visible. The earth cover will not be removed from the earth electrode subsystem for the sole purpose of inspection.

- a. Components will be in good repair.
- b. Components will be free of paint or other nonconductive coating.
- c. Components will be free of corrosion. Discoloration of materials is not considered corrosion.

- d.* Components will be free of breaks, cuts, and damage that will affect equipment integrity.
- e.* All permanent (welded) and semi-permanent (bolted) bonds are in good condition.
- f.* Components will be securely fastened to their mounting surfaces and protected against movement and damage.
- g.* There have not been additions or alterations to the protected facility that would require additional protection or testing.
- h.* Compression clamps are tight.

### **B-3. Earth resistance testing**

The resistance of the earth surrounding the facility should be measured using a four terminal fall-of-potential meter. The reading obtained indicates the average resistance of the soil in the immediate vicinity of the test area. A resistance profile of the site requires that the test be repeated at many sample locations over the region being mapped.

*a.* For small sites, up to 2,500 square feet (232 square meters), make at least one measurement at the center of the site and at each of the four corners of a 50-foot (15 meters) square as shown in figures B-1 and B-2. Drive a stake or marker at the locations shown. Position the potential and current probes in a straight line with the stake or marker centered between the probes. Make a resistance measurement at each location and calculate the resistance. Record the resistance. Take the average of the five readings as the resistance for the soil at the site. If possible, soil measurements should be made during average or normal weather conditions. Measurements should never be made immediately after a rain or storm.

*b.* For larger sites, make measurements every 100 to 150 feet (31 to 46 meters), over the site area. Include in the site area the locations of support elements such as transformer banks, towers, engine-generator buildings, and so forth. Choose a sufficient number of test points to indicate the relative uniformity of the soil composition throughout the area. Be particularly alert for the presence of localized areas of very high or very low resistance soils.

*c.* A single soil resistance measurement is made using the four-probe method in the following manner:

(1) At a location near the center of the site, insert the four short probes supplied with the earth resistance test set into the soil in a straight line as illustrated in figure B-2. A convenient probe spacing of 6 to 9 meters (20 to 30 feet) is recommended as a start. If probes are not supplied with the test set or if they have been lost or misplaced, four metal (steel, copper, or aluminum) rods, 1/4 to 3/8 inch in diameter and 12 to 18 inches in length, may be used. Drill and tap the rod for Nos. 6-32, 8-32, or 10-24 screws, according to rod size and securely fasten the test set leads to the rods. Clamps may also be used for connecting the leads to the probes.

(2) Following the manufacturer's instruction, obtain a resistance reading, *R*, with the test set.

(3) Convert the probe spacing, *A*, to centimeters.

(4) Compute resistance from  $p=6.28RA$  (in ohm-cm). Example: Assume that a resistance of 2 ohms is measured with probe spacings of 20 feet. Convert 20 feet to centimeters: 20 ft. x 30.5 cm/ft. =610 cm. Calculate resistance:  $p=6.28 \times 2 \text{ (ohm)} \times 610 \text{ (cm)}=7662 \text{ ohm-cm}$ .

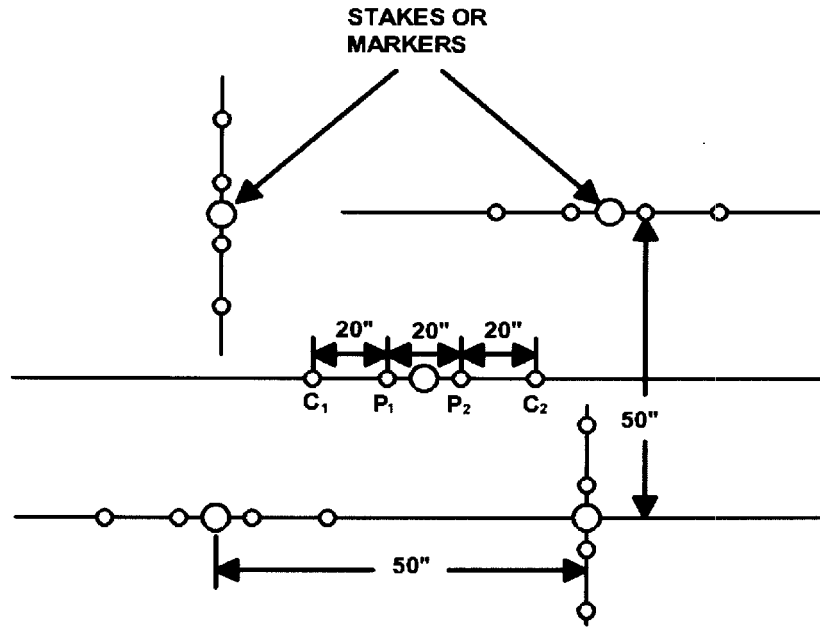
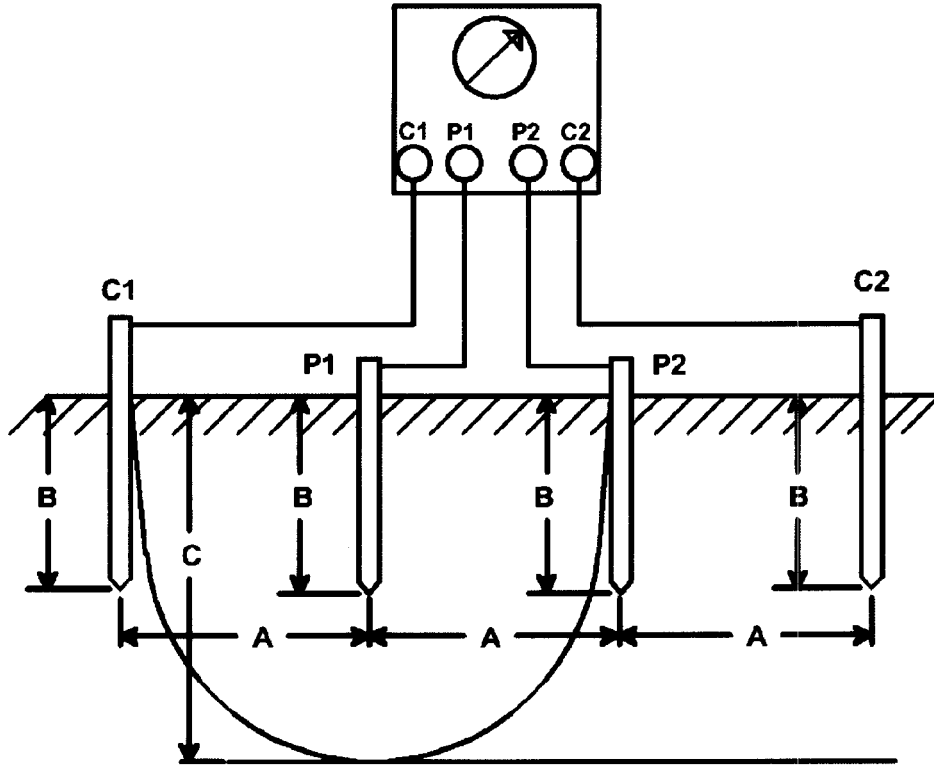

Figure B-1. Measurement of soil resistance



**A = ELECTRODE SPACING**  
**B = DEPTH OF PENETRATION < A/20**  
**C = DEPTH AT WHICH RESISTIVITY IS DETERMINED = A**

Figure B-2. Resistance determination of a small site

#### B-4. Resistance to earth testing

The calculated resistance of a given earth electrode subsystem is based on a variety of assumptions and approximations that may or may not be met in the final installation. Because of unexpected and uncontrolled conditions which may arise during construction, or develop afterward, the resistance to earth of the installed earth electrode subsystem must be measured to see if the design criteria are met. In an existing facility, the resistance to earth of the earth electrode subsystem must be measured to see if modifications or upgrading is necessary. There is only one test method (the 3-point fall of potential method) that is recognized by the Army. The 3-point fall of potential method involves the passing of a known current between the electrode under test and a current probe as shown in figure B-3. The drop in voltage between the earth electrode and the potential electrode located between the current electrodes is then measured. The ratio of the voltage drop to the known current gives a measure of resistance.

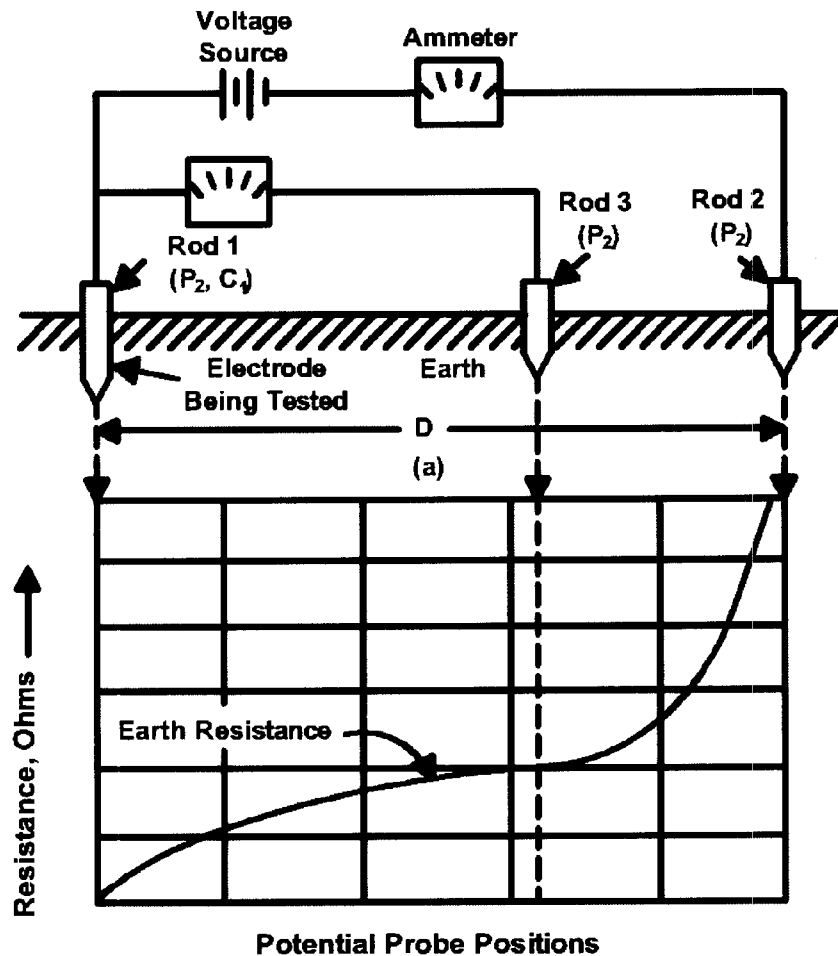

Figure B-3. Fall of potential method for measuring the resistance of earth electrodes

*a. Probe spacing.* Current flow into the earth surrounding an electrode produces shells of equipotential around the electrode. A family of equipotential shells exists around both the electrode under test and the current reference probe. The sphere of influence of these shells is proportional to the size of each respective electrode. The potential probe in figure B-3 provides an indication of the net voltage developed at the earth's surface by the combined effect of these two families of shells. If the electrode under test and the current reference probe are so close that their equipotential shells overlap, the surface voltage variation as measured by the potential probe will vary as shown in figure B-4. Since the current flowing between the electrodes is constant for each voltage measurement, the resistance curve will have the same shape as the voltage curve. For close electrode spacings, the continuously varying resistance curve does not permit an accurate determination of resistance to be made. By locating the current reference probe far enough away from the electrode under test to ensure that the families of equipotential shells do not overlap, a voltage curve like that shown in figure B-4 will be obtained to produce the type of resistance curve shown in figure B-3. When the distance (D) between the electrode under test and the current reference probe is very large compared to the dimensions of the earth electrode subsystem under test, the latter can be approximated as a hemisphere, and interaction between the two electrodes is negligible. Thus the true value of resistance to earth corresponds to the ratio of the potential difference to the measured current when X is 62 percent of the distance (D) from the electrode under test to the current probe. It is important to remember that (D) is measured from the center of the electrode under test to the center of the current probe and that (D) is large relative to the radius of the electrode under test. Figure B-4 shows an example of data taken with the fall-of-potential method. The correct resistance of 13 ohms corresponds to the potential probe location of 27.4 meters (90 feet) which is 62 percent of the distance to the current probe. For a complete explanation of probe spacing see Military Handbook 419.

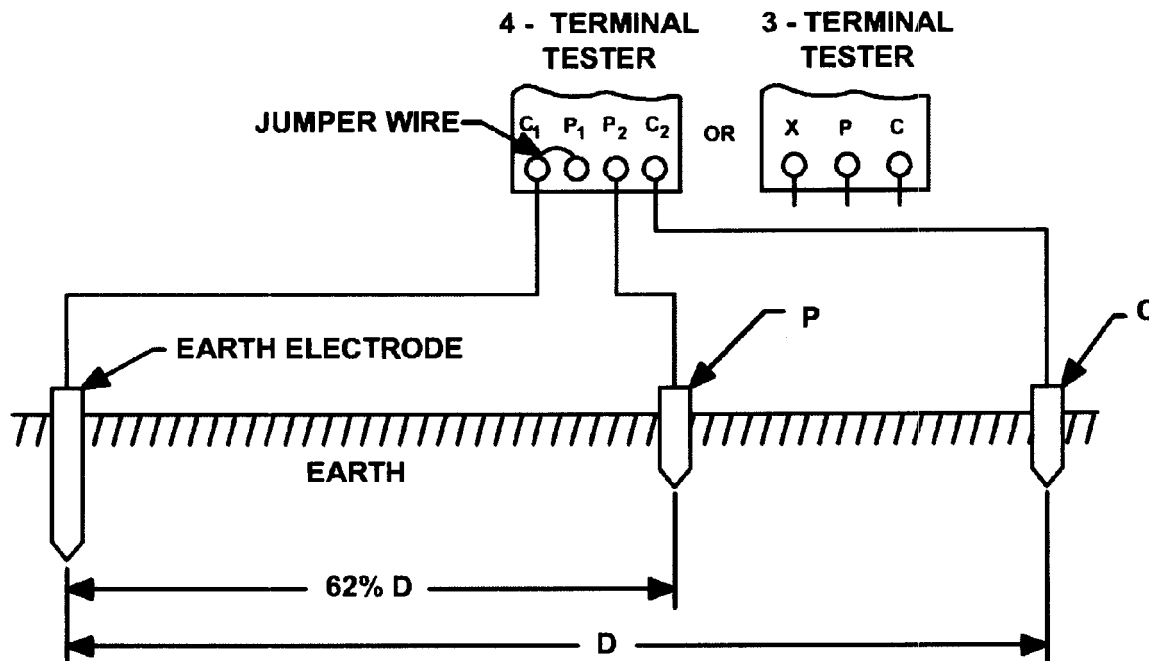

Figure B-4. Fall of potential resistance to earth test

*b. Meters.* Meters for this type of test are manufactured with either three or four terminals. With a four-terminal meter, the P1 and C1 terminals must be interconnected and connected to the earth electrode to be tested. With a three-terminal instrument, connect terminal X to the earth electrode being tested. The earth electrode subsystem will be disconnected when practical. If the earth electrode is directly accessible, connect the C1 P1 terminals or the X terminal of the test meter directly to the earth electrode or interconnecting cable. If the earth electrode is not directly accessible, connect the C1 P1 terminal or X terminal to the lowest portion of the LPS down conductor or a structural ground connection. The driven reference probe C should be driven at the distance (D) from the electrode under test as specified in table B-1. Potential reference probe P is then driven at a point between the earth electrode under test and probe C as specified in table B-1. The test leads should then be connected as shown in figure B-4. Reference probes should be driven to a three-foot depth unless an acceptable reading can be achieved with the reference probes driven to a lesser depth. Operate the test meter in accordance with manufacturer's instructions to obtain the resistance to earth reading. Record the reading.

Table B-1  
Test probe C and P distances

Earth Electrode System	Figure #	Probe C distance (D)	Probe P distance
Ground rods			
Single Rod		40 meters/131 feet	25 m/82 ft
Multiple Rod	17-2	40 meters/131 feet	25 m/82 ft
Ground Loop/ counterpoise	17-3	40 meters/131 feet	25 m/82 ft
Grid	17-5	40 meters/131 feet	25 m/82 ft
Radial	17-6	40 meters/131 feet	25 m/82 ft
Plates	17-7	40 meters/131 feet	25 m/82 ft
Navy installed system	174	40 meters/131 feet	25 m/82 ft



## Appendix C

### Inspection and Test of Static Electricity Charge Dissipation Subsystem

#### C-1. Introduction

This appendix provides criteria and procedures for conducting both visual inspection and electrical testing of static electricity charge dissipation systems.

#### C-2. Visual inspection procedures and criteria

- a. Visual inspection procedures and criteria for conductive floors, mats, and runners.
  - b. Floors mats and runners will be clean, dry, and free of paint or other nonconductive coating.
    - (1) Related equipment (metal parts) will be free of corrosion. Discoloration of materials is not considered corrosion.
    - (2) Floors, mats, and runners will be free of breaks, cuts, and damage that will affect equipment integrity.
    - (3) Bonding straps will not have more than 50 percent of the wire strands broken.
    - (4) Components will be in good repair.
    - (5) Components will not be weakened by vibration.
    - (6) Components will be securely fastened to their mounting surfaces and protected against movement and damage.
    - (7) There have not been additions or alterations to the protected equipment which would require additional protection or testing.
  - c. Visual inspection procedures and criteria for conductive shoes.
    - (1) Conductive sock liners not separated or removed from conductive plug.
    - (2) Conductive plugs not depressed below the insole surface.
    - (3) Conductive soles clean and free of nonconductive materials.
    - (4) No additions or alterations to the footwear which would negate protective properties of the footwear.
  - d. Visual inspection procedures and criteria for belt system.
    - (1) Belts and related equipment will be free of paint or other nonconductive coating.
    - (2) Related equipment (metal parts) will be free of corrosion. Discoloration of materials is not considered corrosion.
    - (3) Belts and related equipment will be free of breaks, cuts, and damage that could affect equipment integrity.
    - (4) Bonding straps will not have more than 50 percent of the wire strands broken.
    - (5) Components will be in good repair.
    - (6) Components will not be weakened by vibration.
    - (7) Components will be securely fastened to their mounting surfaces and protected against movement and damage.
    - (8) There are no additions or alterations to the protected equipment which would require additional protection or testing.
  - e. Visual inspection procedures and criteria for legstats and wriststats.
    - (1) Legstats or wriststats will be free of paint or other nonconductive coating.
    - (2) Legstats or wriststats will be free of corrosion. Discoloration of materials not considered corrosion.
    - (3) Legstats or wriststats will be free of breaks, cuts, and damage that shall affect their integrity.
    - (4) Wriststat bonding straps will not have more than 50 percent of the wire strands broken.
    - (5) Components of legstats or wriststats will be in good repair.
    - (6) There are no been additions or alterations to the protected equipment which would require additional protection or testing.
  - f. Visual inspection procedures and criteria for machinery and equipment.
    - (1) Mating surfaces of machinery and equipment will be free of paint or other nonconductive coatings.
    - (2) Machinery and equipment will be free of corrosion. Discoloration of materials is not considered corrosion.
    - (3) Bonding straps will not have more than 50 percent of the wire strands broken.
    - (4) Machinery and equipment will be in good repair.
    - (5) Components of machinery and equipment will be securely fastened to their mounting surfaces and protected against movement and damage.
    - (6) There are no additions or alterations made to the protected machinery or equipment which would require additional protection or testing.

#### C-3. Electrical testing of conductive floors and mats

- a. *Equipment requirements.*
  - (1) Conductive surface resistance will be measured with a calibrated ohmmeter that operates on nominal open circuit output voltage of 500 V dc with short circuit current of 2.5 mA to 5 mA. Nominal internal resistance must not be less than 100,000 ohms.
  - (2) Accessories required for these tests shall include 2 weighted electrodes. Each electrode shall weigh 5 lbs and have a flat circular contact area 2 1/2 inches in diameter. The contact surface shall be comprised of aluminum or tin

foil .0005 inches to .001 inches thick with a backing layer of rubber 1/4 inch thick. The rubber backing will have a hardness rating of between 40 and 60 based on measurement with a Shore Type A Durometer.

*b. Testing procedures (two electrode).*

- (1) Obtain resistance readings from five different locations on the conductive surface.
- (2) When conducting this test, two electrodes are placed 3 feet apart at each of the 5 test points.
- (3) Record the readings and compute the average of the five locations.
- (4) The average resistance must be more than 25,000 ohms and less than 1,000,000 ohms.
- (5) No individual reading shall be less than 10,000 ohms or more than 5,000,000 ohms.

*Note.* When obtaining resistance measurements, it is recommended that approximately 5 seconds be allowed for meter stabilization before recording reading.

*c. Test procedures (one electrode to ground).*

- (1) Obtain 5 resistance readings to ground. For this test only 1 electrode is placed at each test location on the conductive surface. The meter leads are connected to the electrode and to the ground point.
- (2) The average of the 5 values must be greater than 25,000 ohms with no individual reading less than 10,000 ohms nor more than 1,000,000 ohms.

#### **C-4. Electrical testing of conductive shoes**

*a.* The testing instrument should consist of conductive plates arranged so that the employee stands with only one foot on each plate to complete the circuit. When tests are so made the maximum allowable resistance is 1 million ohms. The test voltage will be no greater than 500 volts. The short circuit current across the electrodes (plates) will not exceed 2.5 milliamperes to 5 milliamperes (0.5 milliamperes is required when the instrument is used with personnel). Positive safeguards must be incorporated into the design of the instruments to eliminate the chance of electric shock to the subject undergoing test. Tests must not be performed in rooms where exposed explosives are present.

*b.* Shoes will be tested first without cleaning the soles and heels and if the resistance does not exceed required limits, the shoes may be put in service. If resistance exceeds 450,000 ohms per shoe when testing, they will be cleaned and retested. If readings are then sufficiently low, the shoes may be returned to service. Those with excessive readings will be destroyed. Sandpaper, solvents, or other agents affecting the structure or conductivity of the sole materials will be avoided. Separation or removal of the conductive sock liners from the conductive plug or depression of the conductive plugs below the surface of the insole of the shoe may cause high resistance.

#### **C-5. Electrical testing of conductive conveyor belts**

*a.* The building will be clean and dry. The room will be free of flammable gas mixtures, explosive dust, and explosives.

*b.* Electrodes will comply with paragraph C-3a.

*c.* Resistance will be measured with a calibrated ohmmeter. The meter will operate on a nominal open circuit voltage of 500 volts DC, or a short circuit current of 2.5 to 5 milliamperes, and have an effective internal resistance of 100,000 ohms.

*d.* Both electrode-to-electrode and electrode-to-earth electrode subsystem measurements will be made at five or more locations on the belt and the results averaged. The average will be below the value specified in table 17-1. When the resistance to the earth electrode subsystem is measured, two measurements will be taken at each of the five test points. The test leads will be interchanged between each of the measurements and the two readings shall be averaged. Electrodes will not be placed closer than three feet from any down conductor or bonding strap (except when space is not available). All readings will be made after the voltage has been allowed to stabilize for 5 seconds. Record the readings.

#### **C-6. Electrical testing of conductive V-belts**

*a.* Requirements of paragraph C-5a apply.

*b.* Requirements of International Standards Organization (ISO) 1813 will be used to test conductive V-belts prior to installation.

*c.* Requirements of paragraph C-5 c apply.

#### **C-7. Electrical testing of legstats**

*a.* Legstats will be tested using any meter capable of measuring resistance in the 0 to 1 megohm range.

*b.* Each legstat will be tested both off and on the wearer. Use paragraph C-4 for testing procedures.

#### **C-8. Electrical testing of wriststats (see table 17-1)**

Wriststats shall be tested in accordance with the publication requiring use of the wriststats.

#### **C-9. Electrical testing of equipment and machinery**

*a.* The requirements in paragraph C-5 a apply.

- b. The meter will be capable of reading 2 ohms.
- c. Measurements will be made, as a minimum, at a location closest to the earth electrode subsystem, at a location farthest from the earth electrode subsystem, and at all locations requiring bonding straps. Test electrodes shall not be placed closer than 3 feet from any LPS down conductor or bonding strap that are attached to down conductors (except when space is not available). Record the readings.

### **C-10. Electrical testing of airfield loading pads**

Use appropriate procedures contained in Appendix B.

## **Appendix D Inspection and Test of Lightning Protection Subsystems**

### **D-1. General requirements**

Lightning protection systems will be visually inspected and tested as specified in table 6-1 for electrical resistance and adequacy of grounding. Any system will be considered deficient if the required resistance value cannot be met. Any system found to be deficient will be repaired. If the deficiency cannot be corrected immediately, the lightning protection system test/maintenance/ace personnel shall record the deficiency on the test record and initiate the following actions:

- a. Notify the installation safety office.
- b. If the deficient system protects an ammunition or explosives storage structure, the custodian of the contents shall be notified.
- c. Interim control measures will be developed based on a risk assessment in accordance with AR 385-10. The risk assessment must include consideration of ceasing operations in and around the building and, for storage facilities, rewarehousing the contents. A decision not to rewarehouse the contents of a storage magazine is justified only when the risk of rewarehousing exceeds the risk associated with the deficient lightning protection system. When use of the facility will continue, maintenance to achieve the required resistance must be accomplished as soon as possible.

### **D-2. Visual inspection of lightning protection subsystem**

Components of the subsystem will be inspected for the following:

- a. Subsystem will meet the requirements specified in NFPA 780.
- b. Components will not be broken.
- c. Components will be in good repair.
- d. Components will be free of corrosion. Discoloration of materials is not considered corrosion.
- e. Components will be free of breaks, cuts, and damage that will affect equipment integrity.
- f. Bonding straps will not have more than 50 percent of the wire strands broken and the remaining portion of the strap will meet the minimum strap thickness and width/cross section requirements of table 17-5.
- g. Components will not be weakened by vibration.
- h. Components will be securely fastened to their mounting surfaces and are protected against accidental mechanical displacement as required.
- i. There have not been additions or alterations to the protected facility which would require additional protection or testing.

### **D-3. Electrical testing of lightning protection subsystems**

a. *Test instruments.* Electrical tests consist of measuring the bonding resistance of the lightning protection subsystem components. The instrument must be capable of measuring resistance up to 1 ohm +10 percent. The manufacturer's instruction manual will be followed to assure proper use of the instrument.

b. *The bonding test.*

(1) The bonding test (see fig D-1) consists of firmly attaching one lead of the ohmmeter to the down conductor where it enters the earth. The earth electrode system will be disconnected when practical. The other lead will then be firmly attached to:

- (a) The other down conductor where it enters the earth (see fig D-1).
- (b) Each component of the lightning protection subsystem.
- (c) Each component of all other subsystems on the facility.
- (d) All large metal bodies (a surface area equal or greater than 400 square inches) that are bonded to the lightning protection subsystem.

(2) Read the meter. If the meter reading is one (1) ohm or less the lightning protection subsystem is acceptable. Record the reading. If the meter reading exceeds one ohm, the lightning protection subsystem is not acceptable.

(3) If lightning protection down conductors are not accessible, the air terminal base may be used as an alternate reference test point for the meter test lead. The air terminal selected should be the same one used to do the 3-point fall of potential test which validates the system's resistance to earth.

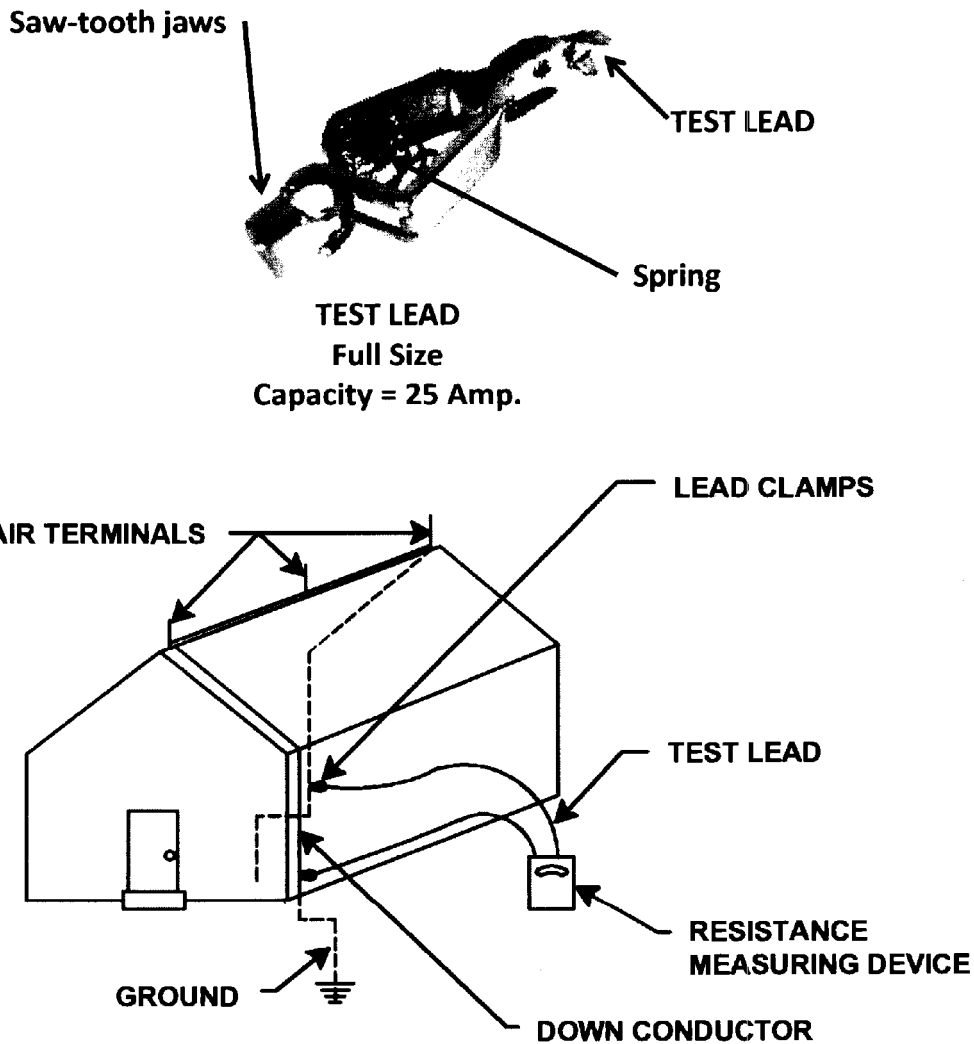

Figure D-1. Testing lightning protection systems

## Appendix E Field Expedient Grounding Techniques

### E-1. Introduction

This appendix provides field expedient grounding techniques.

### E-2. Ground rod technique

- a. Drive a 3-foot ground rod into moist earth to a depth of approximately 30 inches.
- b. Attach a length of cable (having a resistance value of less than 1 ohm) to the item being worked and the driven

ground rod. (Example: When working on propelling charges in the field. Drive the ground rod. Attach one end of the lead to the charge container and the other end to the driven ground rod.)

c. The ground rod will meet the requirements of chapter 17 this pamphlet.

### E-3. The equalization of potential method

This method equalizes the static electricity charge potential between the item and the operator. For this reason the equalization of potential method will be used only when no other method is available. This method consists of the operator touching a mass of bare metal before touching the item being worked. Note: CAUTION: The operator will not touch exposed propellant, electrically sensitive explosives or EEDs.

## Appendix F Safe Conveyor Separation for Ammunition/Explosives

### F-1. Safe separation distances

Safe separation distances are meant for use on conveyor systems at maintenance lines. The distances and precautions given in table F-1 are sufficient to prevent sympathetic detonation.

### F-2. Items Not Listed in Table F-1

For information on items not listed in Table F-1, consult Commander, Joint Munitions Command.

**Table F-1**  
**Safe conveyor spacing**

Nomenclature	Model	Distance	Shield/barrier	Notes
40mm (TNT)		May be placed in contact	None	Projectile only or complete round
57mm (TNT)		6 inches between items	None	Projectile only or complete round
60mm (TNT)		4 inches between items	None	Projectile only or complete round
75mm (TNT)		5 inches between items	None	Projectile only or complete round
76mm (TNT)		5 inches between items	None	Projectile only or complete round
81mm (Comp B)	M374	8 inches between items, for pearlitic malleable iron (PMI) cartridges. 8 inches between items, oriented vertically, with intervening shield, for steel cartridges	For the steel cartridges, the intervening shields must be 2-inch diameter bars with minimum length equal to the length of the cartridges, and may be of steel or aluminum.	Projectile only or complete round
81mm (TNT)		7 inches between items	None	Projectile only or complete round
90mm (TNT)		7 inches between items	None	Projectile only or complete round
90mm, HEAT (Comp B)	M371A1	7 inches between items, oriented horizontally, 20 degrees oblique	None	Composition B loaded projectile with M530A1 PIBD fuze
90mm, HEAT (Comp B)	M371A1	7 inches between items, oriented horizontally, 20 degrees oblique	None	Composition B loaded projectile w/o fuze
90mm, HEAT (Comp B)	M371A1	7 inches between items, oriented horizontally, nose-to-tail	None	Composition loaded complete cartridge
90mm, HEAT (Comp B)	M431A1	7 inches between items, oriented horizontally, 20 degrees oblique	None	Composition B loaded projectile with M509A1 PIBD fuze
90mm, HEAT (Comp B)	M431A1	7 inches between items, oriented horizontally, 20 degrees oblique	None	Composition B loaded projectile w/o fuze
90mm, HEAT (Comp B)	M431A1	7 inches between items, oriented horizontally, nose-to-tail	None	Composition B loaded complete cartridge

**Table F-1**  
**Safe conveyor spacing—Continued**

Burster for 4.2 inch M2A1 cartridge	M14	64 inches between items, oriented end-to-end	None	Bursters from chemical munition projectiles
Burster for projectile, 105mm, M360	M40A1	48 inches between items, oriented end-to-end	None	Bursters from chemical munition projectiles
Burster for projectile, 105mm, M60	M5	8 inches between items, oriented end-to-end	None	Bursters from chemical munition projectiles
Burster for projectile, 155mm, M104, M110	M6	8 inches between items, oriented end-to-end	None	Bursters from chemical munition projectiles
Burster for projectile, 155mm, M121A1	M71	16 feet between items, oriented end-to-end	None	Bursters from chemical munition projectiles
Burster for projectile, 8 inch, M426	M83	24 feet between items, oriented end-to-end	None	Bursters from chemical munition projectiles
Cartridge, HEAT-T, 52mm	M409 series	15 feet between projectiles, center-to-center, in a nose down, vertical orientation	None	Complete round.
Cartridge, 105mm, HEAT-T	M456	23 inches, center-to-center, oriented vertically, w/aluminum bar placed halfway between cartridges; or 15 inches, center-to-center, oriented horizontally, side-to-side, w/aluminum bar placed halfway between cartridges	Barrier bars are aluminum, 6061-T6, 3 inch diameter, and of aluminum length equal to that of the cartridges	Complete round
Cartridge, 105mm, HEAT-T	M456	23 inches, center-to-center, oriented vertically, w/aluminum bar placed halfway between projectiles	Barrier bars are aluminum, 6061-T6, 3 inch diameter, and of aluminum length equal to that of the cartridges	Projectile only
Cartridge, 105mm, HEAT-T	M456	23 inches, center-to-center, oriented vertically, w/aluminum bar placed halfway between cartridges cases, and with protective caps on cases or rapid response deluge protection over cartridge cases	Barrier bars are aluminum, 6061-T6, 3 inch diameter, and of aluminum length equal to that of the cartridge case. Protective caps must be fire resistant, and must protect propellant charge from fire brands and radiant thermal effects.	Primed, loaded cartridge cases.
Cartridge, 105mm, HEAT-T	M456	Empty cases may be placed in contact	None	Empty cartridge cases w/M83 primers
Cartridge, 105mm, HE	M1	15 inches between items oriented nose-to-tail	None	Complete cartridge with primer protected
Cartridge, 105mm, HE	M1	15 inches between items oriented nose-to-tail	None	Complete cartridge w/o fuze, primer protected
Cartridge, 105mm, HE	M1	15 inches nose-to-tail w/ rounds oriented nose-to-tail	None	Fuzed or unfuzed rounds
Cartridge, 106mm HEAT	M344	6 inches between items	None	Complete (nose-to-base)
Cartridge, 20mm, HEI-T-SD	M246	¾ inch (edge-to-edge)	None	Horizontal and perpendicular
Cartridge, 25mm, HEI-T	M792	2.5 inches, center-to-center, oriented vertically	None	Loaded body assembly, w/o fuze
Cartridge, 25mm, HEI-T	M792	2.5 inches, center-to-center, oriented vertically	None	Fuzed projectile only
Cartridge, 25mm, HEI-T	M792	2.5 inches, center-to-center, oriented vertically	None	Complete round
Cartridge, 25mm, HEI-T	M792	One half inch, center-to-center	None	HEI mix pellet, type II, containing 1.94 grams: 97/3 percent RDX/wax (64 percent), aluminum powder (35 percent), and graphite and/or calcium stearate (1 percent)

**Table F-1  
Safe conveyor spacing—Continued**

Cartridge, 25mm, HEI-T	M792	One inch, center-to-center, between stacks	None	Stack of 3 HEI mix pellets, type I, totaling 10.11 grams: 97/3 percent RDX/wax (64 percent), aluminum powder (35 percent), and graphite and/or calcium stearate (1 percent)
Cartridge, 30mm, TP	M788	Zero (in contact)	None	Horizontal and perpendicular to the conveyor travel
Cartridge, 4.2 inch illuminating	M335	No separation required in the horizontal coaxial orientation	None	
Cartridge, 4.2 inch mortar, HE	M329	21 inches between items	None	Cartridge
Cartridge, 81mm	M821	No separation required in the nose-to-tail horizontal coaxial orientation	None	
Cartridge, 81mm	M889	No separation required in the nose-to-tail horizontal coaxial orientation	None	
Cartridge, 81mm, illuminating	M301	No separation required in the horizontal coaxial orientation	None	
Cartridge, 81mm, w/ alloy steel projectile	M374	6 inches between items oriented nose-to-tail	None	With or w/o fuze, and with or w/o propellant.
Cartridge, 90mm, AP-T	M318	No separation required in the horizontal coaxial orientation. The point of the windscreen must not be in contact with the primer of the cartridge in front.	None	
Cartridge, 90mm, APERS-T	M580	7 inches between items, oriented nose-to-tail	None	Complete round
Cartridge, 90mm, Canister	M336	Zero (in contact)	None	Horizontal coaxial (nose-to-tail)
Charge, propelling, 155mm	M4	84 inches tail-to-tail	None	Horizontal oblique, 30 degree angle
Cloud detonator for M130 SLUFAE rocket	M130	4 feet between items center-to-center oriented vertically	None	Steel outer body containing a detonator/delay element, safety and arming mechanism, and two booster pellets loaded with PBXN-5.
Cluster tray for grenade, GP	M42/M46	Zero spacing between trays	Tray is a component for continuous feed conveyor systems used in the load, assembly, and pack of M483 and M509 projectiles	Tray configuration and material of construction must be identical to that depicted in the 4th Ind DRXOS-ESSP, 29 Sep 81, to letter, DRDARLCM-SP, 7 May 81, subject: Test Results Safe Separation Distance Testing of M42/M46 GP Cluster Tray
Composition B		20 feet, side-to-side; or 12 feet, side-to-side, when effective means exist to prevent spread of a fire between buildings via the conveyor.	None	60-lb box.
Explosive D		15 feet, side-to-side	None	50-pound box or fiber container
Fuze, point detonating	M48A3, M51A5, & M557	3 inches between cans	5/16-inch thick paper non-propagation tubes (NSN 8140-01082-9678; dwg #9328329) will replace the normal plastic bottom support for the fuzes	8 fuzes per M2A1 ammunition can with non-propagation tubes, w/o can covers, and w/o nose supports for the fuzes.
Fuze, point detonating	M48A3, M51A5, & M557	6 inches, edge-to-edge, in a nose up orientation	None	Fuze only

**Table F-1**  
**Safe conveyor spacing—Continued**

Grenade, 40mm, cartridge	M406	6 inches, edge-to-edge	None	Edge-to-edge in the horizontal perpendicular position
Grenade, hand, fragmentation	M26	3 inches between grenades	None	Fuzed grenade only
Grenade, hand, fragmentation, delay	M33	12 inches between grenades regardless of orientation	None	Grenade body is a 2.5 inch diameter steel sphere containing 5.5 oz. of Comp B high explosive. Its M213 fuze is equipped with a steel safety pin, but not a safety clip
Grenade, hand, fragmentation, delay	M61	12 inches between grenades regardless of orientation	None	Grenade body is a 2.25 inch diameter consisting of 2 pieces of thin wall sheet steel containing a total of 5.5 oz. of Comp B & .3 oz of tetryl pellets
Grenade, hand, fragmentation, delay	M61	12 inches between grenades regardless of orientation	None	Grenade body is a 2.25 inch diameter consisting of 2 pieces of thin wall sheet steel containing a total of 5.5 oz. Of Comp B & .3 oz of tetryl pellets. Its M20A1/M204A2 incorporates a safety clip
Grenade, smoke	M18	6 inches between grenades	None	Horizontal, side-by-side w/o fuze
Grenade, smoke	M18	6 inches between grenades, fuze-to-base	None	Horizontal, in line w/fuze
Hand grenade, Fragmentation	M67	12 inches, outside edge to outside edge w/o regard to orientation	None	With or w/o M213 fuze.
Loading rings for grenade, GP (for M483 projectile)	M42/ M46	12 inches, outside edge to edge	None	8 grenade ring pack, Loading rings consist of grenades and metal parts constituting one layer in a projectile
Loading rings for grenade, GP (for M509 projectile)	M42/ M46	12 inches, outside edge to edge	None	15 grenade ring pack, Loading rings consist of grenades and metal parts constituting one layer in a projectile
Mine, AP	M74	Zero spacing (edge-to-edge) between the mines and the shield	A rod with a minimum height of 2.6 inches (mine height), 3-inches thick, and a width equal to the conveyor belt.	Complete assembly with 1.3 lbs of RDX, two conical shaped charge plates, two cover plates, and center loaded booster.
Mine, AP	M74	Zero spacing edge-to-edge w/shield described below loaded on the center line and between each mine, 3-inch diameter, 6061-T6 aluminum rod, height of the rod equal to the full height of the mine.	3-inch diameter, 6061-T6 aluminum rod, height of the rod equal to the full height of the mine.	Complete assembly with 1.3 lbs of RDX, two conical shaped charge plates, two cover plates, and center loaded booster.
Mine, AP	M18A1	12 ½ inches (edge-to-edge)	None	Horizontal, front of mine facing up, and side-by-side to each other
Mine, AT, HE, heavy	M15	25 feet between mines	None	Mine only
Mine, AT, HE, heavy	M15	25 feet between mines	None	Mine only, 4 mines per tray
Mine, AT-AV	M75	Zero spaced (edge-to-edge) between the mines and the shield	A rod with a minimum height of 2.6 inches (mine height), 3-inches thick, and a width equal to the conveyor belt.	Complete assembly with 1.3 lbs of RDX, two conical shaped charge plates, two cover plates, and center loaded booster.
Mines, AP, (TNT)	M16	12 inches between mines	None	Mine only
Pentolite (bulk)		35 feet, side-to-side	None	50-pound box or fiber container
Projectile for cartridge, 105mm	M1	15 inches between items, oriented nose-to-tail	None	Comp B loaded, w/o fuze, with lifting plug



**Table F-1**  
**Safe conveyor spacing—Continued**

Projectile for cartridge, 105mm	M1	22 inches between items, oriented horizontally, nose-to-tail	None	Comp B loaded, w/o fuze or nose.
Projectile, 105mm (Comp B)	M1	20 feet between pallets, rounds in vertical orientation, 1-inch apart	Intervening shield of 21 inches by 24 inches by 0.75 SAE 1020 steel.	Pallets of projectiles only, w/o funnels, 16 projectiles per pallet.
Projectile, 105mm (Comp B)	M1	30 feet between pallets, rounds in vertical orientation, 1-inch apart	None	Pallets of projectiles only, w/o funnels, 16 projectiles per pallet.
Projectile, 105mm, HE	M444	24 inches tail-to-tail	None	Horizontal oblique, w/o fuze, 45 degree angle
Projectile, 105mm, HE	M444	36 inches tail-to-tail	None	Horizontal oblique, w/o fuze, 45 degree angle
Projectile, 105mm, HE	M444	72 inches tail-to-tail	None	Vertical, w/o fuze, overhead mono-rail
Projectile, 105mm, illuminating	M314	No separation required between projectiles	None	Horizontal, 45 degrees oblique w/ fuze
Projectile, 105mm, illuminating	M314	No separation required between projectiles	None	Horizontal, 45 degrees oblique w/o fuze
Projectile, 106mm, HEP-T	M346	9 feet between items	None	Projectile
Projectile, 155 mm, HERA	M549	3.5 inches, outside edge to outside edge	3-inch diameter aluminum bar with a minimum length equal to the height of the projectiles placed halfway between projectiles, oriented vertically	Loaded projectiles w/o fuze, w/o lifting plugs
Projectile, 155 mm, HERA	M549	5 feet, center-to-center, oriented vertically, side-to-side	None	Loaded projectiles w/o fuze, with lifting plugs
Projectile, 155mm	M107	18 inches, center-to-center	Intervening shield of 0.5 inches steel, or 1-inch aluminum	This does not apply to ICM projectiles or the M795
Projectile, 155mm, HE	M795	15 feet center-to-center, oriented side-to-side, vertically	None	Single projectiles with loading funnels, filled with cast explosives
Projectile, 155mm, (Comp B or TNT)	M107	18 inches, center-to-center, placed horizontally with a shield located halfway between projectiles	Intervening shield of 0.5 inches thick steel, or 1 inch thick aluminum. A minimum of 9 inches by 25 inches in frontal diameter	Projectile only M107 type. This does not apply to ICM projectiles or the M795
Projectile, 155mm, HE	M449	42 inches positioned horizontally (nose-to-tail or side-by-side); 54 inches positioned vertically	None	Projectile with lifting plug and loaded with expulsion charge and M43 grenades
Projectile, 155mm, smoke	M116	No separation required between projectiles	None	Horizontal, 30 degrees oblique
Projectile, 175mm (Comp B)		15 feet between items	None	Projectile only
Projectile, 30mm, HEDP	M789	3 inches between projectiles (outside edge to outside edge) oriented side-to-side, vertically	None	Heated loaded body assembly with cone temperature of 205 degrees F
Projectile, 30mm, HEDP	M789	3 inches between projectiles (outside edge to outside edge) oriented side-to-side, vertically	None	Fuzed projectile
Projectile, 30mm, HEDP	M789	One inch between assemblies (outside edge to outside edge) oriented side-to-side, vertically	None	Shell body with 2 each, loose PBXN-5 pellets, 27 grams total explosive weight

**Table F-1**  
**Safe conveyor spacing—Continued**

Projectile, 30mm, HEDP	M789	One inch between assemblies (outside edge to outside edge) oriented side-to-side, vertically	None	Loaded body assembly with liner, 0.08 gram PBXN-5 relay charge and steel spacer, at ambient temperature
Projectile, 30mm, HEDP	M789	One inch side-to-side	None	Stacks of 2 each PBXN pellets, type 2, 13.5 grams
Projectile, 8 inch, HE	M106	8 feet edge-to-edge, in the vertical in-line orientation	None	
Projectile, 8 inch, HE	M106	One foot between outside edges with aluminum bar placed halfway between projectiles, oriented vertically	None	Loaded projectile w/o fuze, lifting plug, supplementary charge and liner
Projectile, 8 inch, HE	M404	42 inches positioned horizontally (nose-to-tail or side-by-side); 48 inches positioned vertically	None	Projectile with lifting plug and loaded with expulsion charge and M43 grenades
Projectile, HE, 8-inch	M509	5 feet center-to-center oriented vertically	V shield	Projectile w/o fuze or expulsion charge, at any stage of grenade loading
Rocket	M229	15 inches nose-to-tail	None	Complete round using M423 fuze and MK40 mod 3 motors. Warhead loaded with 4.8 lbs of Comp B-4.
Rocket, 2.75 inch	M151	15 inches nose-to-tail	None	Complete round using M423 fuze and MK40 motor. Warhead loaded with 2.3 lbs of Comp B-4.
Rocket, 3.5 inch, HEAT	M28A2	14 inches between items, placed horizontally at a 20 degree angle to the direction of movement	None	All up round.
Rocket, 3.5 inch, HEAT	M28A2	14 inches between items, placed horizontally at a 20 degree angle to the direction of movement	None	Warhead only, fuzed or unfuzed.
Rocket, 66mm, HEAT	M72	10 inches between items, placed horizontally at a 20 degree angle to the direction of movement	None	Complete round.
Rocket, 66mm, HEAT	M72	10 inches between items, placed horizontally at a 20 degree angle to the direction of movement	None	Warhead only, fuzed or unfuzed.
Submunition	BLU-97/B	4 feet between pallets with barrier placed halfway between	Solid barrier, 0.5 inch thick by 8 inches high by 16 inches wide, 6061-T6 aluminum plate	Pallet of 16 submunitions with solid barrier
Submunition	BLU-97/B	5 feet between pallets with barrier placed halfway between	Airflow barrier	Pallet of 16 submunitions with airflow barrier
Submunition	BLU-97/B	9 inches, center line-to-center line, with full height barrier placed between submunitions	Full barrier, 1.0 inch thick by 6 inches wide by 5.1 inches high, 6061-T6 aluminum plate	Single submunition
Submunition	BLU-97/B	9 inches, center line-to-center line, with partial height barrier placed between submunitions	Partial barrier, 1.0 inch thick by 6 inches wide by 3.75 inches high, 6061-T6 aluminum plate	Single submunition
Tetryl (bulk)		25 feet, side-to-side	None	50-pound box or fiber container
TNT		20 feet, side-to-side; or 12 feet, side-to-side, when effective means exist to prevent spread of a fire between buildings via the conveyor.	None	55-pound box, carton, or fiber container.

**Table F-1**  
**Safe conveyor spacing—Continued**

Warhead	BLU 108/B	17.5 feet from nearest edge of munition on tray to nearest edge of munition on the next tray with a shield between trays	Intervening shield of 1 inch thick aluminum (AL 6061-T6 plate). A minimum frontal dimension of 12 inches by 12 inches. Shield may be located as close as 2 feet, 8.5 inches from nearest tray	4 per tray, vertical, w/o fuze, with or w/o funnel
Warhead, rocket, 5 inch		36 inches tail-to-tail	None	Horizontal, 30 degree oblique, w/o fuze

## Appendix G

### Standard designs for explosives facilities

#### G-1. Drawings approved for new construction

The following drawings are approved for new construction:

*a. Earth-covered magazines.*

- (1) Reinforced concrete arch - 33-15-74.
- (2) Semicircular large steel arch - 421-80-01.
- (3) Semicircular small steel arch - 33-15-65.
- (4) Steel oval arch - 421-80-03.DOD 6055.9.
- (5) Precast concrete arch - 421-80-05.

*b. Other structures.*

- (1) Six bay surveillance facility - 216-12-01.
- (2) Twelve bay surveillance facility - 216-12-02.
- (3) Concrete cubicle - 422-15-01.
- (4) Barricades - 149-30-01.
- (5) Ammo maintenance building 33-69-09.

*c. Facility design drawings can be obtained from US Army Corps of Engineers Huntsville Center's Facilities Standardization Program Home Page located at <http://www.hnd.usace.army.mil/stddgn>, go to "Library Search", click in the 'Category Code' field, and select 'Category Code 400 - "Support Facilities"' from the drop-down menu.*

(1) The intent of this Web site is to host existing standard and definitive design packages which are to be used in the planning and design of military construction projects.

(2) The standards are intended for any federal agency, state and local agency, and private concerns which deal with military construction projects. For information regarding standards not available on the Web site, contact POC at: DLL-CEHNC-FacilitiesStd\_POC@hnd01.usace.army.mil.

#### G-2. Drawings not approved for new construction

Existing buildings constructed using the following drawings are considered to be standard magazines for QD purposes. They are no longer approved for new construction. All the following are ECMs.

- a. Mounded concrete - 33-15-06.*
- b. Stradley - 33-15-61.*
- c. Steel arch - AW33-15-64.*
- d. Steel arch - AW33-15-63.*
- e. Steel arch - 33-15-71.*
- f. Steel oval arch - 33-15-73.*
- g. Atomic blast resistant - 33-15-58.*
- h. Concrete box.*
- (1) USAREUR types I, II, III (330,000 lbs NEW only) - EUR33-15-15.
- (2) USAREUR types I, II, III - 33-15-16.
- i. Camp Darby magazine - 33-15-13.*
- j. Reinforced concrete arch-type, earth-covered magazines - OCE dwg Nos. 652-686 through 652-693.*

#### G-3. Earth-covered magazines

The primary objective of an earth-covered magazine is to provide protection for its assets. To qualify for the default IMDs in table 8-13 magazine, acting as an exposed site, must not collapse. Substantial plastic deformation of the magazine may occur. However, deflections should be limited within the air gap around the stored assets so that the

deformed structure or its doors(s) do not strike the contents. Due to their extreme sensitivities, special protective precautions must be taken for compatibility group (CG) B explosive materials.

a. Table 8–13 contains default intermagazine siting criteria for ECMs with headwall and blast door hardnesses of 7–Bar, 3–Bar, and Undefined. All ECMs in table 8–13 have the same earth cover requirements.

(1) Minimum design considerations for ECMs

(a) Consider conventional (live, dead, snow, and so forth) loads for the barrel of an arch-shaped ECM.

(b) Consider conventional (live, dead, snow, and so forth) and blast-induced loads for the roof of a flat-roofed ECM.

(c) Consider conventional (live, dead, snow, and so forth.) loads for the rear wall of an arch-shaped ECM and for the rear and sidewalls of a flat-roofed ECM.

(d) Consider blast-induced loads for the head wall and door of an ECM.

(2) Expected blast loads from an ECM

(a) The expected blast load on the head wall and door of an exposed site ECM oriented side-on to the side of a PES at a 1.25 W<sup>1/3</sup> distance (feet) is a triangular pulse with peak overpressure of 45 psi (3-bars) and impulse of 11.3W<sup>1/3</sup> psi-ms (1.0Q<sup>1/3</sup> bar-ms).

(b) The expected blast load on the head wall and door of an exposed site ECM oriented head-on to the rear of a PES at a distance of 2W<sup>1/3</sup> (feet) is a triangular pulse with peak overpressure of 100 psi (7-bars) and impulse of 13.9 W<sup>1/3</sup> psi-ms (1.23Q<sup>1/3</sup> bar-ms).

(c) The expected blast load on the roof of a flat-roofed exposed site ECM oriented rear-on to the front of a PES at a distance of 2W<sup>1/3</sup> (feet) is a triangular pulse with peak overpressure of 108 psi (7.5- bars) and impulse of 19W<sup>1/3</sup> psi-ms (1.7Q<sup>1/3</sup> bar-ms).

b. ECMs may be approved for storage of up to 500,000 Pounds NEW of Hazard Division 1.1 in accordance with table 8–15. DDESB Technical Paper No. 15 (TP–15), Approved Protective Construction (reference (ap)), provides listings of the various types of ECM that have been constructed over the years. These magazines are identified by their structural strength designator (that is, “7–Bar”, “3–Bar”, or “Undefined”). Table 4–1 of TP–15 lists the “7–Bar” and “3–Bar” ECM designs that are currently approved for new construction.

(1) If an ECM’s Drawing number is not listed in TP–15, it will be treated as an “Undefined” ECM, until a structural analysis is performed to show that the ECM qualifies for another strength designation, or support documentation is provided to show the ECM had been approved previously by the DDESB with a different strength designation.

(2) For existing, arch-shaped “Undefined” ECM, the Guide for Evaluating Blast Resistance of Non-Standard Magazines may be used to determine if an “Undefined” ECM could qualify as a “7–Bar” or a “3–Bar” ECM.

(3) DDESB approval is required prior to any change in an ECM’s structural strength designator.

(4) Certain ECM, aboveground magazines, and containers have been approved with reduced NEW and/or reduced QD and these are also listed in table 4–4 of TP 15. Use of these structures/containers requires that their use and siting meet all conditions/restrictions specified in the design and approval documentation, as described in TP 15.

#### **G–4. High performance magazines**

The primary objective of a HPM is to reduce the land encumbered by explosives safety quantity distances by limiting the maximum credible event (MCE) to a fraction of the total NEW stored in the HPM. Separation walls also provide protection against fire propagation between storage areas within the HPM. The HPM may be sited at the IMDs as shown in table 8–14. Damage to assets depends on the donor NEW and the scaled separation distance K. IMD provides nearly complete asset protection between HPMs (MCE=60,000 lbs maximum). However, damage may occur to ammunition in an HPM to about K9 from a donor NEW >350,000 lbs.

a. *HPM storage principles.* Because of its construction, each storage cell of the HPM is treated as a separate magazine for the purposes of meeting DOD storage and compatibility requirements. For the purpose of storage within a HPM, all Hazard Division 1.1 and 1.2 ammunition is grouped into five HPM Sensitivity Groups as listed in the JHCS. Within a cell, all current mixing and storage compatibility regulations, as defined in chapter 7, would apply.

b. *The five HPM Sensitivity Groups are—*

(1) HPM Sensitivity Group 1-robust or thick-skinned.

(2) HPM Sensitivity Group 2-non-robust or thin-skinned.

(3) HPM Sensitivity Group 3-fragmenting.

(4) HPM Sensitivity Group 4-cluster bombs/dispenser munitions.

(5) HPM Sensitivity Group 5- other - items that are prohibited or items for which HPM non-propagation walls are not effective (per JHCS).

c. When HPM Sensitivity Groups are mixed, the most sensitive group controls the allowable explosives weight in an adjacent cell. When HD1.3, 1.4 and 1.6 are stored with HD1.1 or 1.2, the sensitivity groups of the HD1.1 and 1.2 control the storage requirements for explosives safety.

d. For the purpose of assigning HPM Sensitivity Groups, an item should be placed into Group 1 when any two of the following criteria are met:

(1) Explosive weight/empty case weight < 1.

- (2) Case thickness > 0.4 inches.
- (3) Case thickness/NEW<sup>1/3</sup> > 0.05 in/lb<sup>1/3</sup>.
- e. If an item does not meet the criteria shown above for Group 1 and it is not a candidate for Group 4 (cluster bombs/dispenser munitions), then, it should be considered for Group 2.
- f. Group 3 items have cases designed for fragmentation-items with preformed fragment warhead, scored cases, continuous rod warheads, and so forth. These items are usually air-to-air missile warheads.
- g. Items are assigned to Group 5 because of their sensitivity. Either it is known that the item can be very sensitive or the sensitivity of the item has not been established.
- h. Item specific testing and/or analyses can and should be used to change the HPM sensitivity group of an item.

### **G-5. Other magazines**

Existing magazines described by definitive drawings and specifically approved for the purpose by USATCES are approved for storage of ammunition and explosives.

a. Prior DDESB safety review and approval is required for new types of ammunition and explosives storage facilities and for existing facilities being proposed for use in storing ammunition and explosives.

b. The allowable explosives weight in cells adjacent to cells containing HPM Sensitivity Groups 1, 2, and 3 ammunition: 30,000 lbs in cell; 60,000 lbs in loading dock. The allowable explosives weight in cells adjacent to cells containing HPM Sensitivity Group 4 ammunition: 15,000 lbs in cell (side - side); 60,000 lbs in loading dock. (See High Performance Magazine Definitive Drawings: NFESC 99220001-99220012.)

c. Reduced QD magazines will be used in accordance with the latest DDESB guidance for the specific magazine and/or TP 15.

## **Appendix H The 100-Foot Zone of Protection**

### **H-1. Introduction**

This appendix provides the theory and criteria for applying the 100-foot striking arc applicable to LPS requirements for explosives facilities.

### **H-2. Zone of protection**

The zone of protection includes the space not intruded upon by an arc having a radius of 100 feet. This zone is the area beneath the point where the arc contacts earth and rests against an air terminal of an LPS. A zone of protection is also created when the arc rests on the tips of two properly spaced air terminals. All possible placements of the arc must be considered when determining the zone of protection using the 100-foot concept. Figures H-1 through H-4 illustrates these areas of protection.

### **H-3. Zone of protection for earth-covered magazines**

When determining the zone of protection for earth-covered magazines, the actual earth cover should not be considered as part of the structure that requires lightning protection. Figures H-5 through H-7 demonstrate the application of the 100-foot striking zone arc for earth-covered magazines.

a. The depicted earth-covered magazines have ventilators that extend approximately 3 feet above the earth cover and headwalls which extend approximately 1 foot. The air terminals extend 2 feet above the ventilator and the headwall.

b. Magazines that project above the earth cover may require additional air terminals to provide an adequate zone of protection.

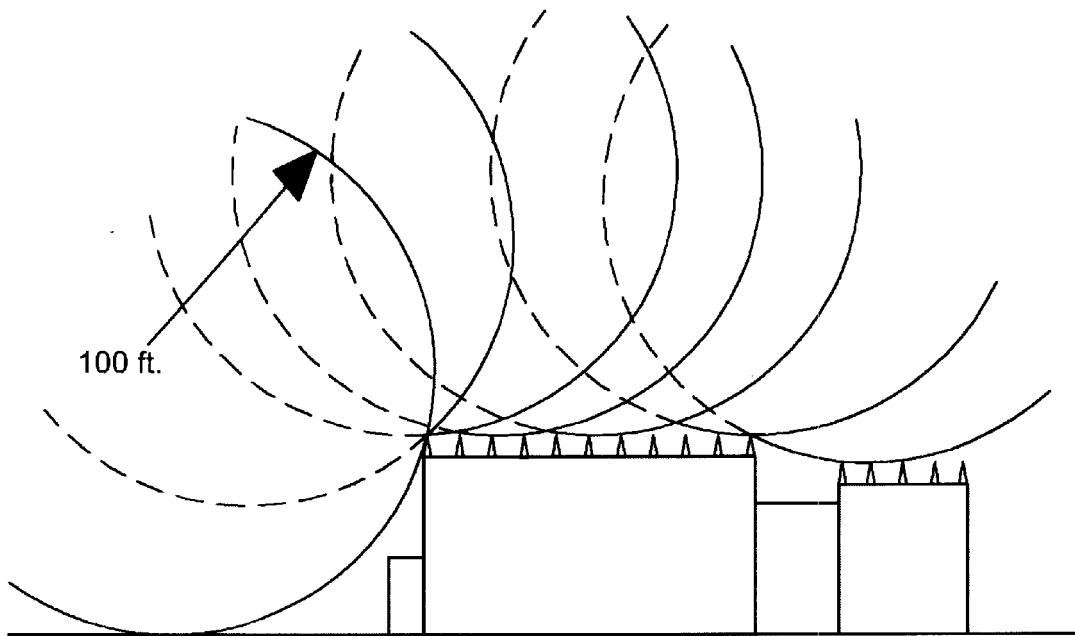

Figure H-1. Zone of Protection Test

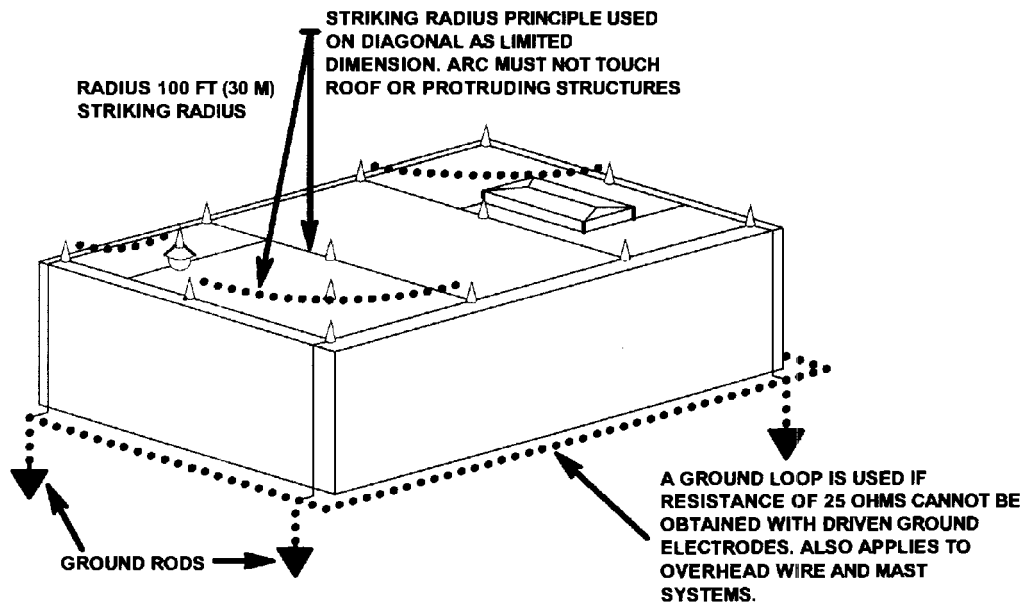

Figure H-2. Zone of protection for integral systems

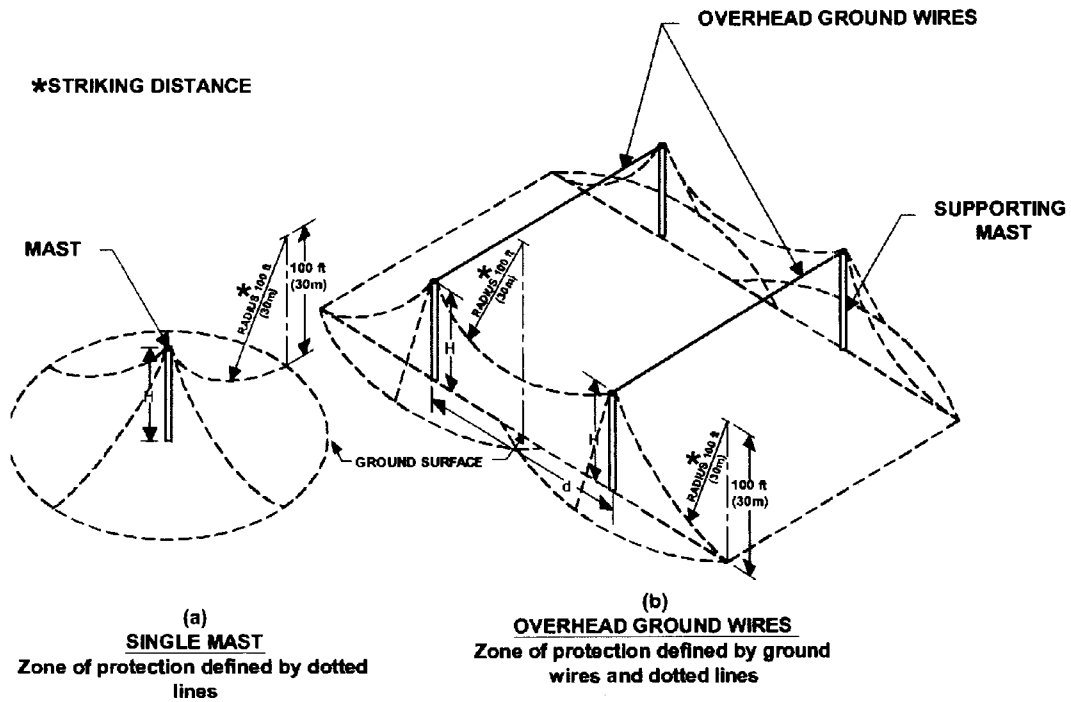
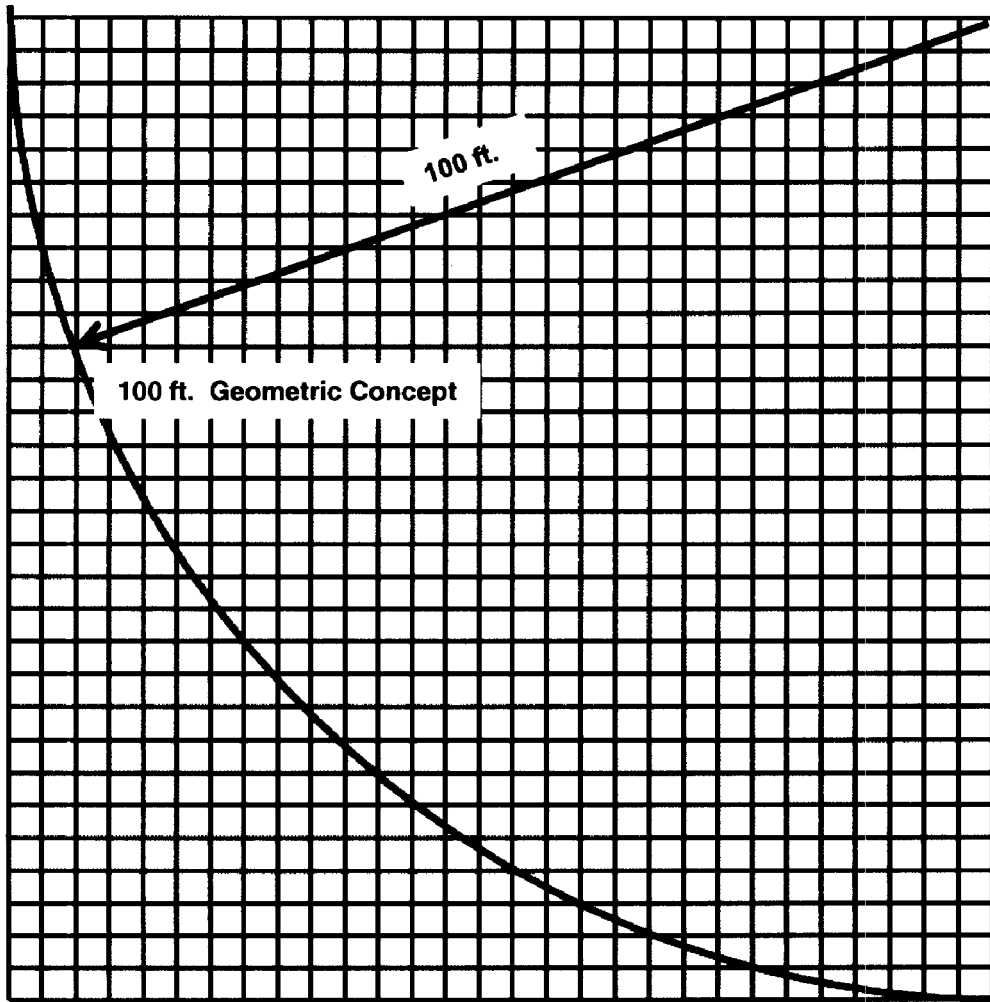

Figure H-3. Illustrated zone of protection



Horizontal Distance, ft

**NOTE: The distance may be determined analytically for a 100 ft. (30m) striking distance with the following equation:**

$$D = \sqrt{h_1(200 - h_1)} - \sqrt{h_2(200 - h_2)}$$

**Where: d = horizontal distance, ft**

**$h_1$  = height of higher roof, ft**

**$h_2$  = height of lower roof, ft**

**Zone of protection = 100 ft (30m) striking distance.**

Figure H-4. Zone of protection geometric concept



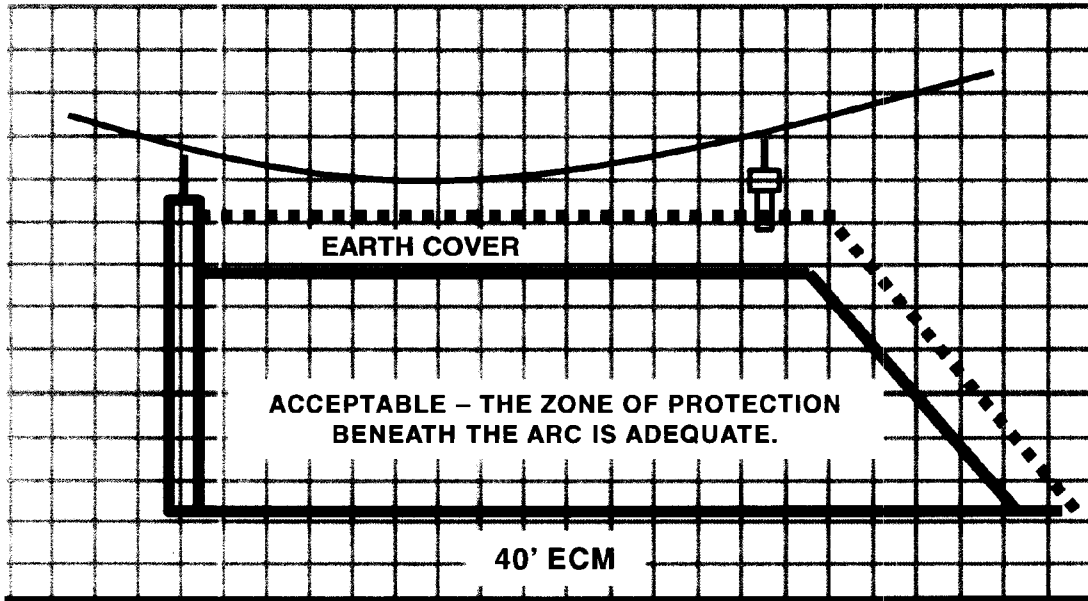

Figure H-5. Adequate protection not penetrating earth cover

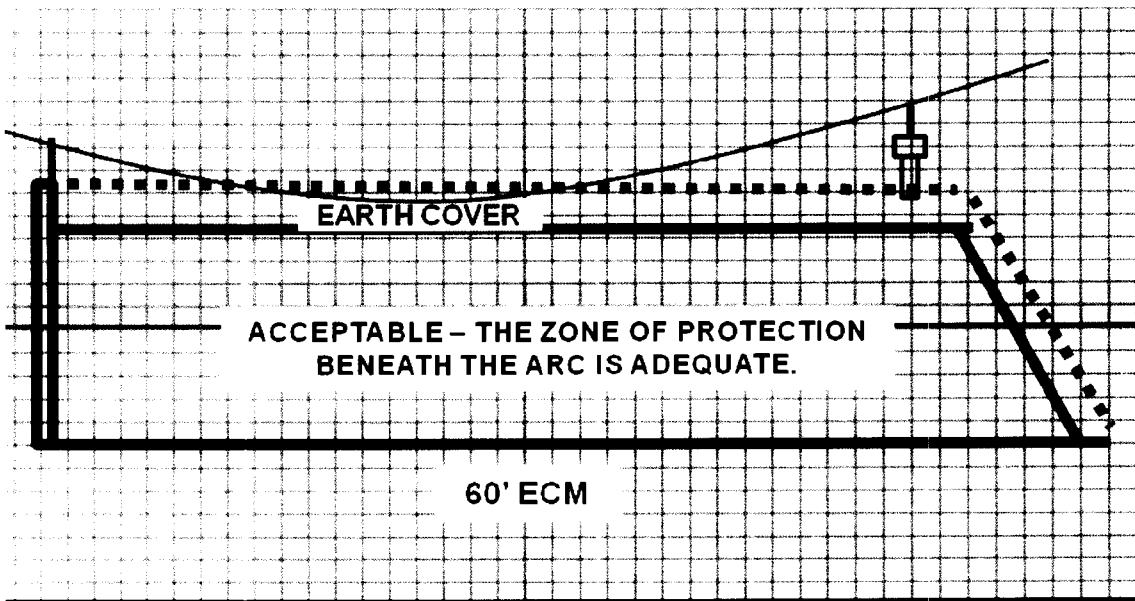

Figure H-6. Adequate protection penetrating earth cover

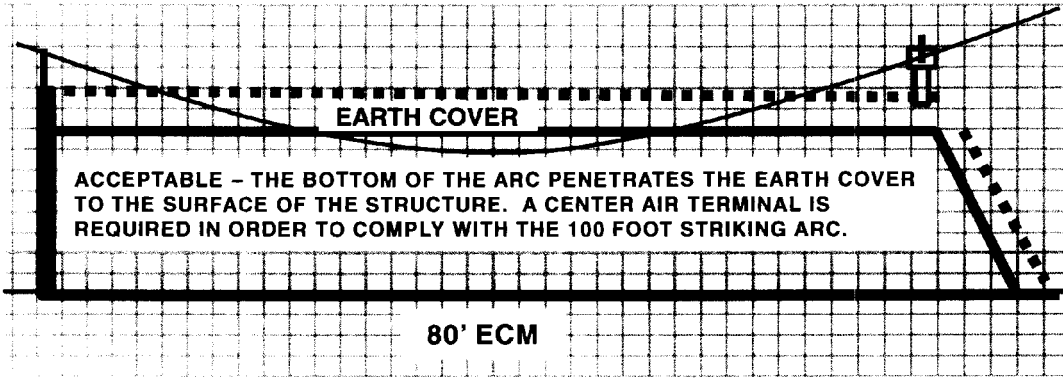

Figure H-7. Inadequate protection penetrating earth cover

## **Glossary**

### **Section I Abbreviations**

**AAE**

arms, ammunition, and explosives

**AAR**

after action report

**AC**

active component

**ACOM**

Army Commands

**ADCAP**

Advanced capabilities torpedoes

**AE**

ammunition and explosives

**AFFF**

aqueous film-forming foam

**AGM**

above ground magazine

**AGS**

above ground site

**AHA**

ammunition holding area

**AMC**

U.S. Army Materiel Command

**ANSI**

American National Standards Institute

**APA**

ammunition and prohibited area

**APE**

ammunition peculiar equipment

**AR**

Army regulation

**ARNG**

Army National Guard

**ASA (IE&E)**

Assistant Secretary of the Army (Installations, Energy & Environment)

**ASCC**

Army Service Component Commands

**ASME**

American Society of Mechanical Engineer

**ASP**

ammunition supply point

**ASR**

Archive Search Report

**ASU**

ammunition storage unit

**ATP**

ammunition transfer point

**ATHP**

Ammunition transfer holding point

**AWG**

American wire gauge

**A/D**

approach/departure

**BIP**

blow-in-place

**BLAHA**

basic load ammunition holding area

**BOE**

Bureau of Explosives

**BOM**

Bureau of Mines

**BRAC**

base realignment and closure

**BWM**

Biological Warfare Material

**BZ**

3-quinuclidinyl benzilate

**C**

Celsius

**CAD**

cartridge activated devices

**CAIS**

chemical agent identification sets

**CBU**

cluster bomb unit

**CCI**

controlled cryptographic item

**CCL**

combat configured load

**CCR**

Certificates of compelling reason

**CE**

conditional exception

**CEA**

Captured enemy ammunition

**CER**

Chemical event reports

**CERCLA**

Comprehensive Environmental Response Compensation and Liability Act

**CFR**

Code of Federal Regulations

**CG**

compatibility group

**CIC**

Commercial intermodal containers

**CONUS**

Continental United States

**CONWEP**

Conventional Weapons Effects Program

**CORA**

Certificate of Risk Assessment

**CRC**

Combat Readiness Center

**CWM**

Chemical Warfare Material

**DA**

Department of Army

**DA Pam**

Department of Army pamphlet

**DASA (ESOH)**

Deputy Assistant Secretary of the Army (Environment, Safety, and Occupational Health)

**DDESB**

Department of Defense Explosives Safety Board

**DERP-FUDS**

Defense Environmental Restoration Program - Formerly Used Defense Sites

**DL**

Distance learning

**DMM**

Discarded Military Munitions

**DRMO**

Defense Reutilization and Marketing Office

**DOD**

Department of Defense

**DODD**

Department of Defense Directive

**DODIC**

Department of Defense identification code

**DOT**

Department of Transportation

**DQO**

Data quality objectives

**DRMO**

Defense Reutilization and Marketing Office

**DRU**

Direct Reporting Units

**DSN**

Defense switched network

**DTR**

Defense Transportation Regulation

**ECM**

earth-covered magazine

**EED**

electro-explosive device

**EE/CA**

Engineering Evaluation/Cost Analysis

**EIDS**

extremely insensitive detonating substance

**EMR**

electromagnetic radiation

**EOD**

explosives ordnance disposal

**EP**

Engineers Pamphlet

**EPA**

Environmental Protection Agency

**EPCRA**

Energy Planning Community Right-to-Know Act

**ERG**

Emergency Response Guidebook

**ES**

exposed site

**ESMP**

Explosive Safety Management Program

**ESQD**

explosive safety quantity distance

**ESS**

Explosives Safety Submission

**F**

Fahrenheit

**FAE**

fuel-air explosive

**FARP**

forward area rearm/refuel point

**FLOT**

forward line of own troops

**FME**

foreign material exploitation

**FORSCOM**

United States Army Forces Command

**fpm**

feet per minute

**fps**

feet per second

**FSC**

Federal Supply Class

**FSU**

field storage unit

**FUDS**

Formerly Used Defense Site

**GBL**

Government bill of lading

**GPM**

gallons per minute

**HAD**

heat activated devices

**HAS**

hardened aircraft shelter

**HC**

hexachloroethane

**HD**

hazard division

**HE**

high explosive

**HFD**

Hazardous Fragmentation Distance

**HPM**

High Performance Magazine

**HQDA**

Headquarters, Department of Army

**HRS**

Historical Record Search

**HTRW**

Hazardous, Toxic, and Reactive Waste

**IBD**

inhabited building distance

**ICM**

improved conventional munitions

**ID**

identification

**IFR**

instrument flight rules

**IHC**

Interim Hazard Classification

**IL(B)**

intraline, barricaded

**ILD**

intraline distance

**IL(U)**

intraline, unbarricaded

**IMCOM**

Installation Management Command

**IMD**

intermagazine distance

**INPR**

Inventory Project Report

**ips**

inches per second

**IR**

Infrared



**ISO**

International Standards Organization

**JHCS**

Joint Hazard Classification System

**JMC**

Joint Munitions Command

**LCL**

Less than carload

**LEPL**

Local emergency planning committee

**LOI**

Letter of Instruction

**LP**

liquid petroleum

**LPS**

lightning protection system

**LTL**

Less than truckload

**LUC**

Land use controls

**MAG**

Magazine

**MC**

munitions constituents

**MCA**

military construction, Army

**MCE**

maximum credible event

**MDAS**

material documented as safe

**MDEH**

material documented as explosive hazard

**MEC**

Munitions and Explosives of Concern

**MFD**

Maximum fragmentation distance

**MGBH**

Munition with the greatest blast hazard

**MGFPC**

Munition with the greatest fragment penetration capability

**MGHFD**

Munition with the greatest hazardous fragmentation distance

**MGMFD**

Munition with the greatest maximum fragment distance

**MHE**

material handling equipment

**MILVAN**

military demountable container

**MIL-STD**

military standard

**MMCX**

Military Munitions Center of Expertise

**MOA**

Memorandum of Understanding

**MOD**

models

**MOOTW**

military operations other than war

**MOU**

memorandum of understanding

**MP**

military police

**MPPEH**

material potentially presenting an explosive hazard

**MPS**

maritime prepositioning of ships

**MR**

munitions rule

**MRA**

munitions response area

**MRESS**

munitions response explosives safety submission

**MRS**

munitions response site

**MSD**

minimum separation distance

**MSDS**

material safety data sheet

**MWD**

military working dog

**NATO**

North Atlantic Treaty Organization

**NAVFAC**

naval facility

**NDAI**

No DOD Action Indicated

**NEC**

National Electrical Code

**NEQ**

net explosive quantity

**NEW**

net explosive weight

**NEWQD**

net explosive weight for quantity-distance

**NFPA**

National Fire Protection Association

**NGB**

National Guard Bureau

**NICP**

National Inventory Control Point

**NOFA**

no further action

**NSN**

national stock number

**NTCRA**

non time-critical response action

**OB**

open burning

**OCE**

Office of Chief Engineers

**OCONUS**

outside the continental United States

**OD**

open detonation

**ODASA (ESOH)**

Office of the Deputy Assistant Secretary of the Army for Environmental, Safety, and Occupational Health

**ODASAF**

Office of the Director of Army Safety

**OSHA**

Occupational Safety and Health Administration

**P&P**

packaging and preservation

**PA**

preliminary assessment

**PAD**

propellant activated devices

**PEO**

Program Executive Officer

**PES**

potential explosion site

**PM**

program manager

**POL**

petroleum, oils, and lubricants

**PPE**

personal protective equipment

**PPWR**

prepositioned war reserve

**PREPO**

Pre positioning program

**PSI**

pounds per square inch

**PSP**

pre-stock point

**PTR**

public traffic route

**PTRD**

public traffic route distance

**PWP**

plasticized white phosphorous

**QA**

Quality Assurance

**QASAS**

quality assurance specialist (ammunition surveillance)

**QC**

quality control

**QD**

quantity-distance

**RAC**

risk assessment code

**RC**

reserve component

**RCRA**

Resource Conservation and Recovery Act

**RCW**

reinforced concrete wall

**RDTE**

Research, Development, Test, & Evaluation

**RDX**

Research Department Explosive

**RF**

radio frequency

**RI/FS**

Remedial investigation/feasibility study

**RIP**

relief in place

**ROD**

record of decision

**RORO**

roll on, roll off

**ROTC**

Reserve Officer Training Corps

**RSP**

render safe procedures

**SA**

Secretary of the Army

**SAA**

Small arms ammunition

**SAE**

Society of American Engineers

**SDDC**

Military Surface Deployment and Distribution Command

**SDW**

substantial dividing wall

**SF**

standard form

**SI**

site inspection

**SIR**

serious incident report

**SOF**

Special Operations Forces

**SOP**

standing operating procedure

**SPP**

Systematic planning process

**SUXO**

Senior UXO Supervisor

**TA**

terephthalic acid

**TAO**

Transfer of Authority

**TB**

technical bulletin

**TCRA**

Time Critical Removal Action

**TEA**

Triethylaluminum

**TEU**

Technical Escort Unit

**TH**

thermite

**TM**

technical manual

**TNT**

trinitrotoluene

**TO**

transportation officer

**TOFC**

trailer-on-flat car

**TP**

target practice

**TPA**

thickened pyrophoric agent

**TPP**

Technical project planning

**TSD**

Team separation distance

**UFC**

United Facilities Criteria

**UL**

Underwriter's Laboratory

**UNO**

United Nations Organization

**USACE**

United States Army Corps of Engineers

**USAEC**

US Army Environmental Center

**USAESCH**

US Army Engineering and Support Center, Huntsville

**USATCES**

United States Army Technical Center for Explosives Safety

**USCG**

United States Coast Guard

**UV**

ultraviolet

**UXO**

unexploded ordnance

**VAC**

volts alternating current

**VFR**

visual flight rules

**VX**

nerve agent O-ethyl-S-(2-isopropylaminoethyl) methylphosphonothiolate

**WMM**

Waste military munitions

**WP**

white phosphorous

**Section II****Terms****Aboveground magazines**

Any open area or any structure used for explosives storage that does not meet the requirements of an ECM.

**Administration area**

The area in which administrative buildings that function for the garrison or installation as a whole, excluding those offices located near and directly serving components of explosives storage and operating areas, are located.

**Aircraft parking area**

Any area set aside for parking aircraft not containing explosives.

**Aircraft passenger transport operations**

Passenger transport traffic involving military dependents and civilians other than those employed by or working directly for DOD components.

**Ammunition and explosives**

Includes, but is not necessarily limited to, all items of U.S.-titled (i.e., owned by the U.S. Government through the

DOD Components) ammunition; propellants, liquid and solid; pyrotechnics; high explosives; guided missiles; warheads; devices; and chemical agent substances, devices, and components presenting real or potential hazards to life, property and the environment. Excluded are wholly inert items and nuclear warheads and devices, except for considerations of storage and stowage compatibility, blast, fire, and non-nuclear fragment hazards associated with the explosives. (See Military Munitions.)

**Ammunition and explosives aircraft cargo area**

An area designated for the temporary storage of transportation configured loads of ammunition and explosives. These loads may or may not be loaded on the aircraft.

**Ammunition and explosives area**

An area specifically designated and set aside from other portions of a garrison or installation for the development, manufacture, testing, maintenance, storage, disposal, or handling of ammunition and explosives.

**Ammunition and explosives holding area**

An area that is used for temporary storage, weapons assembly and staging. This area is established to fulfill the operational requirements of the various types of FARPs.

**Ammunition and explosives staging area**

An area used as a transient area for A&E. This area may be used for staging all-up-round weapons, staging weapons to support daily aircraft requirements, or for the assembling convoys.

**Ammunition logistics assistance representatives**

Ammunition logisticians, generally working within the Ammunition Logistics Assistance Program, who provide conventional ammunition logistical support to the warfighter and Unified Combatant Commands and provide feedback to AMC Life Cycle Management Commands.

**Ammunition storage unit**

All types of explosives storage magazines including outdoor or indoor, open storage areas, sheds, bunkers, and earth-covered and above-ground magazines.

**Anomaly**

For MEC projects, any item that is seen as a subsurface irregularity after geophysical investigation. This irregularity should deviate from the expected subsurface ferrous and non-ferrous material at a site (that is, pipes, power lines, and so forth).

**Anomaly avoidance**

For MEC projects, consists of techniques employed by EOD or UXO personnel at sites with known or suspected MEC to avoid any potential surface MEC and any subsurface anomalies. This usually occurs at mixed hazard sites when Hazardous, Toxic, and Reactive Waste (HTRW) investigations must occur prior to execution of an MEC removal action. Intrusive anomaly investigation is not authorized during ordnance avoidance operations. An MEC safety specialist may also be assigned to the site to provide government safety and/or quality assurance oversight.

**Archives search report**

A detailed investigation to report on past MEC activities conducted on a garrison or installation. The principal purpose of the Archives Search Report effort is to assemble historical records and available field data, assess potential MEC presence, and recommend follow-up actions. There are four general steps in an Archives Search: records search phase, site safety and health plan, site survey, archives search report including risk assessment.

**Armament pads**

A location where ammunition is located for immediate loading onto combat aircraft or vehicles.

**Army accident**

An unplanned event or series of events that results in damage to Army property, occupational illness to Army military or civilian personnel, injury or death to Army military personnel on- or off-duty, injury to on-duty civilian personnel, damage to public and private property, or injury or illness to non-Army personnel as a result of Army operations.

**Asset preservation**

A level of protection provided to assets in an exposed site (from a PES) by either distance from a PES or from



protective construction design features that ensure that there is no propagation of reaction from the PES to the exposed site assets, and that the assets are expected to be usable following an incident in the PES.

**Auxiliary building**

Any building ancillary to, or maintained and operated to serve, an operating building, line, plant, or pier area.

**B-duration**

The total time in milliseconds for the noise pressure to rise to peak and then fall back. To the human ear there is only a single sound. Specialized equipment is required to measure the sound wave to determine its B-duration. Procedures to calculate impulse noise B-duration from measured sound waves are in Mil Std 1474.

**Barge piers**

Piers and wharfs used exclusively for loading/unloading explosives on barges or utility craft.

**Barricade**

An intervening barrier, natural or artificial, of such type, size, and construction as to limit in a prescribed manner the effect of an explosion on nearby buildings or exposures.

**Base realignment and closure**

Program governing the scheduled realignment and/or closure of DOD sites via Congressional legislation.

**Basic load ammunition holding area**

A storage area for basic load ammunition located within the boundaries of a barracks or in the immediate vicinity thereof, in armored vehicles, trucks, trailers, structures, or on pads to ensure mission readiness. The BLAHAs consist of one or more storage sites and involve acceptance of risks to personnel, facilities and equipment that are greater than that normally permitted.

**Biological warfare materiel**

An item configured as a munitions containing an etiologic agent that is intended to kill, seriously injure, or incapacitate a person through its physiological effects. Biological warfare materiel can also include etiologic agents that are designed to damage or destroy crops that are intended for human consumption.

**Blast overpressure**

The pressure, exceeding the ambient pressure, manifested in the shock wave of an explosion.

**Blow-in-place**

The act of destroying MEC where it is found, without moving it, rather than transporting it to another location for destruction.

**Boss lift**

An event in which civilian employers of National Guard and Army Reserve Soldiers get to see and experience what their employees do during military training.

**Buildings presenting munitions and explosives of concern explosives hazards**

Buildings (including their installed equipment) with explosives residues that present explosion hazards. Many former munitions processing facilities contain explosives residues. These residues may be located in installed equipment, in cracks in the building floors or walls, in drains, and in many other places. If these residues are in such amounts or concentrations as to present explosion hazards, then the residue is considered MEC.

**Build-up location**

A location where ammunition is prepared for use. For example, bomb fins are attached to bombs, rockets assembled and fused, and so forth.

**Burning grounds**

The area dedicated to burning of energetic materials. This includes actual burning sites and facilities dedicated to the burning operation.

**Burning site**

The actual location used for the burning of energetic materials, for example, a burning pan.

**Captive missile**

A captive missile is a practice missile containing only an active guidance section - no warhead, no motor. There is no energetic matter except for a possible squib or two to power the guidance section.

**Captured enemy ammunition**

All ammunition products and components produced for or used by a foreign force that is hostile to the United States [that is or was engaged in combat against the United States] in the custody of a U.S. military force or under the control of a DOD Component. The term includes confined gaseous, liquid, and solid propellants, explosives, pyrotechnics, chemical and riot control agents, smokes, and incendiaries, including bulk explosives, and chemical warfare agents, chemical munitions, rockets, guided and ballistic missiles, bombs, warheads, mortar rounds, artillery ammunition, small arms ammunition, grenades, mines, torpedoes, depth charges, cluster munitions and dispensers, demolition charges, and devices and components of the above. CEA can also include NATO or U.S. manufactured munitions that may not have been under U.S. custody or control.

**Cell**

Various small compartments or bounded areas forming part of a module.

**Certificate of Risk Acceptance (CORA) (DA Form 7632)**

Permanent written documentation of command's acceptance of the risk associated with an event that does not meet regulatory requirements and/or exposes Soldiers, civilian and contractor personnel, the public, or real property to a risk at greater than a de minimis threshold. An informal risk acceptance process may be substituted for a CORA for one-time events of one week or less duration but a CORA is highly recommended. CORA will be used to replace all waivers and exemptions that currently use DA Form 7319-R, which is obsolete, during the next required review cycle but not later than 1 October 2011.

**Change house**

A building provided with facilities for employees to change to and from work clothes.

**Chemical agent**

A substance that is intended for military use with lethal or incapacitating effects upon humans through its chemical properties. Excluded from chemical agents for purposes of this standard are riot control agents, chemical herbicides, smoke-and flame-producing items, and individual dissociated components of chemical agent ammunition.

**Chemical ammunition**

Ammunition, the filler of which has the basic function of producing a toxic or irritant effect on the body, a screening or signaling smoke, or an incendiary action.

**Chemical munitions and agents**

An agent or munitions that through its chemical properties, produces lethal or other damaging effects to human beings, except that such term does not include riot control agents, chemical herbicides, smoke and other obscuration materials.

**Chemical warfare materiel**

An item configured as a munitions containing a chemical agent that is intended to kill, seriously injure, or incapacitate a person through its physiological effects. Also includes V- and G-series nerve agent, H-series blister agent, and lewisite in other than munitions configurations. Due to their hazards, prevalence, and military-unique application, CAIS are also considered chemical warfare materiel. Chemical warfare materiel does not include riot control agents; chemical herbicides; smoke and flame producing items, regardless of configuration; or soil, water, debris, or other media contaminated with chemical agent.

**Classification yard**

A railroad yard used for receiving, dispatching, classifying, and switching of cars.

**Clearance to depth**

The location, excavation, and removal of MEC to its depth of detection.

**Closure block**

A protective construction feature designed to seal the entrance tunnel to an underground storage chamber in the event of an explosion within the chamber. MAGAE blocks are passive closures that are driven by the blast from a normally open to a closed position. KLOTZ blocks are active closures, operated by a hydraulic system to move from a normally closed to an open position (for access).

**Combat aircraft parking area**

Any area specifically designated for parking aircraft loaded with combat-configured explosives, or those being loaded, unloaded, or awaiting loading. This includes aircraft hangars and alert shelters.

**Combat configured load**

A mixed ammunition package designed to provide for the complete round concept, type of unit, type of vehicle, capacity of transporter, and weapons system. Contents of the package are predetermined and provide optimum quality and mix to support a particular weapons system or unit.

**Commercial intermodal container**

Containers used for transportation of DOD A&E that have met standards established by the International Organization for Standardization (ISO). These containers are also referred to as ISO, freight and dry cargo commercial containers.

**Compatibility**

Ammunition or explosives are considered compatible if they may be stored or transported together without increasing significantly either the probability of an accident or, for a given quantity, the magnitude of the effects of such an accident.

**Compatibility group**

The compatibility group for ammunition, explosives and/or other hazardous materials which can be stored and/or transported together without significantly increasing the probability of accident or, for a given quantity, the magnitude of the effects of such an accident. The compatibility groups are based on the system recommended for international use by the United Nations Organization (UNO) and as adopted by NATO and the Department of Defense.

**Competent authority**

An individual of the armed forces designated in command, responsible for the direction, coordination and control of military forces. The commander alone is responsible for everything his or her unit does or fails to do. He or she cannot delegate his or her responsibility, or any part of it although he or she may delegate portions of his or her authority to competent individuals. An individual designated by the commander to address areas of primary interest within that individual's technical expertise.

**Component**

Any part of a complete item whether loaded with explosives, inert (not containing explosives), or empty (not filled with explosives).

**Conditional exemption**

An exemption from the regulatory definition of hazardous waste (and therefore from compliance with specific environmental requirements pertaining to the storage of hazardous waste) conditioned on compliance with certain criteria requirements as set forth in 40 CFR 266.205.

**Construction support**

Support provided by qualified UXO personnel during construction activities at potential MEC sites to ensure the safety of construction personnel from the harmful effects of MEC. There are two types of support: standby support, and active support. Standby construction support applies when a determination is made that the probability of encountering MEC is low (seldom or unlikely). UXO personnel will stand by and identify any MEC items encountered. If an item is encountered, UXO personnel assume site control and destroy the item or move it to a safe location for later disposal. Active construction support applies when a determination is made that the probability of encountering MEC is moderate to high (occasional, likely or frequent). UXO personnel conduct subsurface MEC clearance for the known construction footprint either in conjunction with the construction contractor or prior to construction intrusive activities.

**Conventional munitions and explosives of concern**

The term "conventional MEC" refers to MEC (see definition) other than CWM, Biological Warfare Material (BWM) and nuclear ordnance.

**Conveyance**

A truck, tractor trailer, railcar or commercial intermodal container (CIC) used for transportation of ammunition, explosives or hazardous material.

**Debris**

Any solid particle thrown by an explosion or other strong energetic reaction. For aboveground detonations, debris

usually refers to secondary fragments. For underground storage facilities, debris refers to both primary and secondary fragments, which are transported by a strong flow of detonation gases.

**Debris trap**

A protective construction feature in an underground storage facility that is designed to capture fragments and debris from a detonation within the facility. This is usually accomplished by using the inertia of the material to separate it from the detonation gas stream. (See figure 5–9.)

**Defense sites**

Locations that are or were owned by, leased to, or otherwise possessed or used by the Department of Defense. The term does not include any operational range, operating storage or manufacturing facility, or facility that is used for or was permitted for the treatment or disposal of military munitions. (10 USC 2710(e)(1)).

**Deflagration**

A rapid chemical reaction in which the output of heat is enough to enable the reaction to proceed and be accelerated without input of heat from another source. Deflagration is a surface phenomenon with the reaction traveling along the surface at subsonic velocity.

**Demilitarize**

To mutilate, disarm, neutralize, and accomplish any other action required to render ammunition, explosives, and chemical agents innocuous or ineffectual for military use.

**De minimis threshold**

An upper limit representing a level of probability below which a hazard does not warrant any expenditure of resources to track or mitigate. Traditionally, a probability of less than 1 in a million is associated with the upper limit for a de minimis threshold. From the Latin phrase “de minimis non curat lex” which means, “the law does not concern itself with trifles.”

**Designated aircraft parking area**

An aircraft parking area that meets airfield parking criteria.

**Detonation**

A violent chemical reaction within a chemical compound or mechanical mixture involving heat and pressure. A detonation is a reaction which proceeds through the reacted material toward the non-reacted material at a supersonic velocity. A detonation, when the material is located on or near the surface of the ground, is normally characterized by a crater.

**Discarded military munitions**

Military munitions that have been abandoned without proper disposal or removed from storage in a military magazine or other storage area for the purpose of disposal. The term does not include unexploded ordnance, military munitions that are being held for future use or planned disposal, or military munitions that have been properly disposed of, consistent with applicable environmental laws and regulations. (10 USC 2710(e)(2)).

**Disposal**

End of life tasks or actions for residual materials resulting from demilitarization or disposition operations.

**Disposition**

The process of reusing, recycling, converting, redistributing, transferring, donating, selling, demilitarizing, treating, destroying, or fulfilling other life-cycle guidance, for Army property.

**Distribution lines**

Electrical lines supplying multiple garrison or installation locations.

**Dividing wall**

A wall designed to prevent, control, or delay propagation of an explosion between quantities of explosives on opposite sides of the wall.

**Dolphin**

A mooring post or posts on a wharf or quay.

**Dud**

Explosive munitions which have not armed as intended or which has failed to function after being armed. (See misfire.)

**Dummy ammunition**

Ammunition or ammunition components having the appearance of actual items and not having any explosives components, normally used in non-live fire training events.

**Earth-covered magazine**

Any earth-covered structure that meets the soil cover depth and slope requirements of chapter 8. ECMs have three possible structural strength designations (7-bar, 3-bar, or Undefined). The strength of an ECM's headwall and door(s) determines its designation.

**Electrical lines**

See transmission lines, distribution lines, or service lines.

**Empty ammunition**

Ammunition or ammunition components void of any type of filler.

**Engineering evaluation/cost analysis**

An EE/CA is prepared for many non time critical responses. The goals of the EE/CA are to identify the extent of a hazard, to identify the objectives of the response action and evaluate various alternative MEC responses for the site in terms of effectiveness, implementation, cost, and other factors; and, based on this comparison, recommend an appropriate response.

**Engineering controls**

Regulation of facility operations through the use of prudent engineering principles, such as facility design, operation sequencing, equipment selection, and process limitations.\

**Essential ammunition and explosives personnel**

Essential ammunition and explosives (AE) personnel are Army Soldiers, civilian employees, DOD personnel, other service members, and contractor personnel that a commander or a responsible authority determines must, by virtue of their duties, must be exposed to the risks associated with ammunition and explosives operations. They may include, but are not limited to personnel who:

- a. Directly perform AE operations (such as, production, storage, transportation, EOD, quality assurance, research, engineering, testing, and demilitarization).
- b. Directly support AE operations (for example, personnel dedicated as AE drivers, emergency response, security, maintenance, inventory, and so forth).
- c. Provide support services or perform functions that require occasional or periodic proximity to AE operations (such as, maintenance personnel, cleaning personnel, vending machine operators, safety personnel, engineers, and so forth). These personnel are considered essential only for the limited period for which the exposure is necessary. See definition of nonessential personnel below.

**Exclusion zone for munitions and explosives of concern operations**

A safety zone established around an MEC work area. Only project personnel and authorized, escorted visitors are allowed within the exclusion zone. Examples of exclusion zones are safety zones around MEC intrusive activities and safety zones where MEC is intentionally detonated.

**Exemption**

A written authority that permits long-term noncompliance with mandatory requirement of U.S. Army ammunition and explosives safety standards. Existing Exemptions will be replaced at their next scheduled review date and all exemptions will be replaced not later than 1 October 2011.

**Expansion chamber**

A protective construction feature in an underground storage facility which is designed to reduce the blast shock and overpressure exiting the facility by increasing the total volume of the complex. It may also function as an operating area within the underground facility, as well as a debris trap. (Illustrated in figure 5-10).

**Explosion**

A chemical reaction of any chemical compound or mechanical mixture that, when initiated, undergoes a very rapid

combustion or decomposition, releasing large volumes of highly heated gases that exert pressure on the surrounding medium. Depending on the rate of energy release, an explosion can be categorized as a deflagration or a detonation.

**Explosives anchorage**

An area of water specifically designated for loading and unloading and anchoring vessels carrying a cargo of ammunition and explosives.

**Explosives area**

A restricted area specifically designated and set aside from other portions of a garrison or installation for the manufacturing, processing, storing, and handling of ammunition and explosives.

**Explosives facility**

Any structure or location containing ammunition and explosives, excluding combat aircraft parking areas or ammunition and explosives aircraft cargo areas.

**Explosive hazard**

A condition where danger exists because explosives are present that may react (for example, detonate, deflagrate) in a mishap with potential unacceptable effects (such as, death, injury, damage) to people, property, operational capability, or the environment.

**Explosives-loaded aircraft**

An aircraft is 'explosives-loaded' when it carries munitions or explosives, internally or externally. The term does not include explosive components of aircrew escape systems or pyrotechnics installed in survival and rescue kits.

**Explosive ordnance disposal**

The detection, identification, field evaluation, rendering safe, recovery, and destruction of MEC. It may also include the rendering safe and/or disposal of explosive ordnance that have become hazardous by damage or deterioration when the disposal of such is beyond the capabilities of personnel normally assigned the responsibility for the routine disposal.

**Explosives ordnance disposal personnel**

Military personnel who have graduated from the Naval School, EOD; are assigned to a military unit with a Service-defined EOD mission; and meet Service and assigned unit requirements to perform EOD duties. EOD personnel have received specialized training to address explosive and certain chemical agent hazards during both peacetime and wartime. EOD personnel are trained and equipped to perform RSP on nuclear, biological, chemical, and conventional munitions, and on improvised explosive devices.

**Explosives or munitions emergency**

A situation involving the suspected or detected presence of MEC, damaged or deteriorated explosives or munitions, an improvised explosive device, other potentially explosive material or device, or other potentially harmful military chemical munitions or device, that creates an actual or potential imminent threat to human health, including safety, or the environment, including property, as determined by an explosives or munitions emergency response specialist.

**Explosives or munitions emergency response**

All immediate response activities by an explosives and munitions emergency response specialist to control, mitigate, or eliminate the actual or potential threat encountered during an explosives or munitions emergency. May include in-place render-safe procedures, treatment or destruction of the explosives or munitions and/or transporting those items to another location to be rendered safe, treated, or destroyed. Any reasonable delay in the completion of an explosives or munitions emergency response caused by a necessary, unforeseen, or uncontrollable circumstance will not terminate the explosives or munitions emergency. Explosives and munitions emergency responses can occur on either public or private lands and are not limited to responses at RCRA facilities.

**Explosives safety**

A condition where operational capability and readiness, people, property, and the environment are protected from the unacceptable effects or risks of potential mishaps involving military munitions.

**Explosives safety specialist**

A U.S. Government civilian in a safety career field with specialized training and background in DOD and DOD Component explosives safety standards and procedures.

**Exposed site**

A location exposed to the potential hazardous effects (blast, fragments, debris, and heat flux) from an explosion at a PES.

**Explosives sited aircraft parking area**

An aircraft parking area that meets both explosives safety and airfield criteria.

**Explosive soil**

Explosive soil refers to mixtures of explosives in soil, sand, clay, or other solid media at concentrations such that the mixture itself is explosive.

*a.* The concentration of a particular explosive in soil necessary to present an explosion hazard depends on whether the particular explosive is classified as “primary” or “secondary.” Guidance on whether an explosive is classified as “primary” or “secondary” can be obtained from the USATCES or chapters 7 and 8 of TM 9–1300–214.

*b.* Primary explosives are those extremely sensitive explosives (or mixtures thereof) that are used in primers, detonators, and blasting caps. They are easily detonated by heat, sparks, impact, or friction. Examples of primary explosives include Lead Azide, Lead Styphnate, and Mercury Fulminate.

*c.* Secondary explosives are bursting and boosting explosives (for example, they are used as the main bursting charge or as the booster that sets off the main bursting charge). Secondary explosives are much less sensitive than primary explosives. They are less likely to detonate if struck or when exposed to friction or to electrical sparks. Examples of secondary explosives include RDX, Trinitrotoluene (TNT), Composition B, and Ammonium Picrate (Explosive D).

*d.* Soil containing ten percent or more by weight of any secondary explosive or mixture of secondary explosives is considered “explosive soil.” This determination was based on information provided by the USAEC as a result of studies conducted and reported in USAEC Report AMXTH–TE–CR 86096.(e) Soil containing two percent or more by weight of any primary explosive or mixture of primary explosives is considered “explosive soil.” This determination was based on information provided by the USAEC as a result of studies conducted and reported in USAEC Report SFIM–AEC–ET–CR–97015.

*e.* Soil containing propellants or pyrotechnic compositions (as opposed to primary or secondary high explosives) may also present explosion hazards. However, threshold percentages have not been established.

**Field office**

An office required by operational supervision; for example, foremen and line supervisors, in direct support of ammunition and explosives operations.

**Firebrand**

A projected burning or hot fragment whose thermal energy is transferred to a receptor.

**Fire hazard area**

A location in which the primary, but not necessarily the only, hazard is that of fire, including “explosions” of gas or vapor and air mixtures.

**Fire-resistive**

A term used to indicate the property of structures or materials to resist a fire to which they might be subjected, without themselves becoming weakened to the point of failure.

**Fire-retardant**

A term used to designate generally combustible materials or structures which have been treated or have surface coverings designed to retard ignition or fire spread.

**Fire wall**

A wall of fire-resistive construction designed to prevent the spread of fire from one side to the other. A fire wall may also be termed a “fire division wall.”

**Fixed ammunition**

Ammunition, except small arms and rocket ammunition, consisting of a cartridge case loaded with propellant and a projectile which are loaded in one operation into the weapon, the cartridge case being firmly attached to the projectile.

**Flame-resistant**

A term applied to combustible materials, such as clothing, which have been treated or coated to decrease their burning characteristics.

**Flammable**

A material which has the characteristic of being easily ignited and burning readily.

**Flightline munitions holding area**

Designated location on the flightline where built up munitions is temporarily placed pending delivery to combat aircraft or return to storage.

**Formerly used defense sites**

Those properties previously owned, leased, or otherwise possessed by the United States and under the jurisdiction of the Secretary of Defense; or manufacturing facilities for which real property accountability rested with DOD but operation was performed by contractors (Government owned - contractor operated) and later the facilities were legally disposed.

**Forward arming and refueling point**

A temporary facility, organized, equipped and deployed by an aviation commander, and normally located in the main battle area closer to the area of operation than the aviation unit's combat service area, to provide fuel and ammunition necessary for the employment of aviation maneuver units in combat. The FARP permits combat aircraft to rapidly refuel and rearm.

**Fragment**

A piece of exploding or exploded munitions. Primary fragments may be complete items, subassemblies, pieces thereof, or pieces of equipment that are in immediate contact with explosives. Secondary fragments are from pieces of equipment or buildings containing the item(s).

**Fragment distance**

The limiting range, based on a specific density of hazardous fragments, expected from the type and quantity of explosives involved. Used in establishing certain QD criteria. A hazardous fragment is a fragment having an impact energy of 58 foot-pounds or greater. Hazardous fragment density is a density of hazardous fragments exceeding one per 600 square feet.

**Fragmenting munitions**

Items that have cases that are designed to fragment in a specified manner. Examples include continuous rod warheads, items with scored cases and items that contain pre-formed fragments. Items that fit this definition are usually air-to-air missile warheads such as Sparrow and Sidewinder.

**Garrison**

A permanent military post for stationing of Soldiers.

**General public**

Persons not associated with a DOD installation's mission or operations such as visitors, to include guests of personnel assigned to the garrison or installation, or persons not employed or contracted by DOD or the garrison or installation.

**Geophysical investigation techniques**

Techniques utilized for the detection and measurement of buried anomalies (for example, ferromagnetic indicators and ground penetrating radar) to investigate the presence of munitions.

**Hangfire**

Temporary failure or delay in the action of a primer, igniter, or propelling charge.

**Hazard**

Any existing or potential condition that can cause injury, illness, or death of personnel, or damage to or loss of equipment or property.

**Hazard analysis**

The logical, systematic examination of an item, process, condition, facility, or system to identify and analyze the probability, causes, and consequences of potential or real hazards.

**Hazard class**

The United Nations Organization (UNO) hazardous classification system, which contains nine hazard classes, is used



by the DOD for dangerous materials to identify the hazardous characteristics of AE. Hazard Class 1 (A&E) is further divided into seven division designators that indicate the primary characteristics and associated hazards.

**Hazardous fragment**

A fragment having an impact energy of 58 ft-lb or greater and/or a weight greater than 2,700 grains (6.17 ounces or 175.5 grams).

**Hazardous fragment density**

A density of hazardous fragments exceeding one hazardous fragment per 600 square feet.

**Hazardous fragment distance**

The distance to which a hazardous fragment density of one hazardous fragment per 600 feet is projected.

**Hazardous material**

The component of, or an item of, ammunition that is inherently designed to produce the necessary energy required for ignition, propulsion, detonation, fire or smoke, thus enabling the item to function. Also, a material (corrosive, oxidizer, and so forth), which inherently is dangerous and capable of serious damage and which, therefore, requires regulated handling to avoid creating accidents in connection with its existence and use.

**Heavy armor**

Main battle tanks or other vehicles that are expected to contain fragments and reduce blast over pressure generated from the detonation of ammunition contained internally.

**High explosive equivalent or explosive equivalent**

The amount of a standard explosive that, when detonated, will produce a blast effect comparable to that which results in the same distances from the detonation or explosion of a given amount of the material for which performance is being evaluated. For the purpose of these standards, TNT is used for comparison.

**High performance magazine**

The HPM is an earth-bermed, 2-story, box-shaped structure. Story-1 contains the ammunition storage areas and loading dock. Each storage cell has earth-bermed or non-propagation walls on all four sides and a reinforced concrete cover. Story-2 is a lightweight pre-engineered metal building that provides environmental protection for the ammunition transfer area. The non-propagation walls and storage area covers are designed to limit the maximum credible event, MCE, in the HPM to 60,000 lbs. The MCE, rather than NEW, is used to calculate safe separation distances.

**Holding area**

A temporary location used to store ammunition and explosives until it can be safely moved to a permanent storage area.

**Holding yard**

A location for groups of railcars, trucks, or trailers used to hold ammunition, explosives, and dangerous materials for interim periods before storage or shipment.

**Hygroscopic**

A tendency of material to absorb moisture from its surroundings.

**Hypergolic**

A property of various combinations of chemicals to self-ignite upon contact with each other without a spark or other external initiation.

**Imminent danger**

Imminent danger is defined as any conditions or practices in any place of employment which is such that a danger exists which could reasonably be expected to cause death or serious physical harm immediately or before the imminence of such danger can be eliminated.

- a. Requirements. The following conditions must be met before a hazard becomes an imminent danger:
- b. There must be a threat of death or serious physical harm. "Serious physical harm" means that a part of the body is damaged so severely that it cannot be used or cannot be used very well.
- c. For a health hazard there must be a reasonable expectation that toxic substances or other health hazards are present and exposure to them will shorten life or cause substantial reduction in physical or mental efficiency. The harm caused by the health hazard does not have to happen immediately.

*d.* The threat must be immediate or imminent. This means that you must believe that death or serious physical harm could occur within a short time, before an official could investigate the problem.

*e.* Section 13 of 29 USC 662, Public Law 91–596 84 STAT. 1590 91st Congress, S.2193, December 29, 1970, as amended through January 1, 2004.

**Inert ammunition**

Ammunition containing no explosives or chemical agents.

**Inert area**

Any area other than an ammunition or explosives area within an establishment.

**Inert components**

The parts of ammunition that do not contain explosives or chemical agents.

**Inhabited buildings**

Buildings or structures, other than operating buildings occupied in whole or in part by human beings, both within and outside DOD installations. They include but are not limited to schools, churches, residences (quarters), Service clubs, aircraft passenger terminals, stores, shops, factories, hospitals, theaters, mess halls, post offices, and post exchanges.

**Inhabited building distance**

The minimum distance permitted between an inhabited building and an ammunition or explosives location for the protection of administration, quarters, industrial and other similar areas within a garrison or installation. At this distance personnel are not expected to be killed or seriously injured. Vehicles and aircraft will be serviceable without damage from blast, but may be struck by fragments. Unstrengthened structures, tents, thin-skinned aluminum or sheet metal, modular offices, will sustain superficial damage. This distance is required to all inhabited structures and critical mission assets.

**Inspection station**

A designated location at which trucks and railcars containing ammunition and explosives are inspected.

**Installation**

Army installations are defined as an establishment used for military purposes but not primarily for the stationing of Soldiers. They include such locations as depots, activities, ports, ammunition supply points, basic-load ammunition storage areas, and ammunition plants. Installations also refer to DOD establishments in an inactive, standby or layaway status; facilities awaiting closure under BRAC, other legislation, or under normal procedures for excess property, and other closed facilities not yet transferred from Army control. Examples on inactive, standby or layaway installations include but are not limited to posts, camps (including National Guard camps), forts, depots, activities, ports, ammunition supply points, basic load ammunition storage areas, and ammunition plants.

**Installation related personnel**

Military personnel (to include family members), DOD employees, DOD contractor personnel, or other personnel having either a direct operational (military or other Federal personnel undergoing training at an installation) or logistical support (such as, vendors) relationship with installation activities.

**Interchange yard**

An area set aside for the exchange of railroad cars or vehicles between the common carrier and DOD activities.

**Intraline distance**

The distance to be maintained between any two operating buildings and sites within an operating line, of which at least one contains or is designed to contain explosives, except that the distance from a service magazine for the line to the nearest operating building may be not less than the ILD required for the quantity of explosives contained in the service magazine. At this distance personnel will sustain serious injury or even death. Vehicles and aircraft will be extensively damaged or a total loss. Unstrengthened buildings will receive extensive damage. Ammunition supplies will survive but may be damaged beyond use.

**Intrusive activity**

For MEC projects, an activity that involves intentional physical contact with MEC or intentional penetration of the ground surface at an area known or suspected to contain MEC. Examples include surface or subsurface MEC sampling or removal.

**Inventory project report**

The report resulting from the preliminary assessment of eligibility. The INPR includes data as well as a recommendation for further action and guides investigators through further site studies. Documents whether DOD is responsible for contamination at a FUDS.

**Joint DOD non-DOD use runway/taxiway**

A runway/taxiway serving both DOD and commercial aircraft. A runway/taxiway serving solely DOD, DOD chartered, or Non-DOD aircraft on DOD authorized business is not Joint use.

**Joint-use airfield**

An airfield serving both DOD and commercial aircraft. An airfield serving solely DOD, DOD chartered, or non-DOD aircraft on DOD authorized business is not Joint use.

**K-factor**

The factor in the formula  $D=KW^{1/3}$  used in quantity-distance determinations where D represents distance in feet and W is the net explosive weight in pounds. The K-factor is a constant and represents the degree of damage that is acceptable. Typical constants range from 1.25 to 50; the lower the factor; the greater the acceptance of damage. K-factors also correspond with specific overpressure levels.

**Land use controls**

For MEC projects, refers to methods of controlling MEC hazards without physically removing the MEC. Includes, without being limited to, security fencing or other measures to limit access, provision of alternate water supplies, temporary evacuation and housing of threatened individuals not otherwise provided for, post-removal site control, land repurchase, deed restrictions, zoning, building permits, and any emergency assistance that may be provided under the Disaster Relief Act of 1974.

**Launch pads**

The load-bearing base, apron, or platform upon which a rocket, missile, or space vehicle and its launcher rest during launching.

**Light armor**

Armored vehicles that are not expected to contain the fragments or over pressure of a detonation of the internally stored ammunition but whose armor does give protection from an external detonation. For example, M113 series vehicles are considered light armor.

**Limited quantities**

The minimum amount of ammunition required in support of operational missions (for example, for security guard forces, military police, and so forth) or the immediate training requirements of the unit owning the facility. For HD 1.2. 2 this may not exceed 50 pounds NEW and for HD 1.3 this may not exceed 100 pounds NEW.

**Liquid propellants**

Substances in fluid form (including cryogenics) used for propulsion or operating power for missiles, rockets, ammunition, and other related devices (See table 5–16). Hydrocarbon fuels used in the operation of ships, aircraft and other vehicles are not considered liquid propellants for the purpose of this pamphlet. Those dual purpose hydrocarbon fuels which are used in both missiles/rockets/ammunition and in ships/aircraft/vehicles are considered liquid propellants only when the fuel is actually charged into the missile/rocket/ammunition.

**Loading density**

Quantity of explosive per unit volume usually expressed in pounds per cubic foot (lbs/ft<sup>3</sup>). As applied to underground storage facilities, there are two types of loading densities used in QD calculations:

a. Chamber loading density is based on the NEW within an individual storage chamber and the volume of the chamber (VCH).

b. The calculation of airblast peak pressures and IBDs for explosions in underground storage facilities is based on the shock-engulfed volume (VE) of the facility. This is the total volume filled by the expanding gases at the time the blast front reaches the point of interest (for example, the entrance to an adjacent chamber). It includes volumes in any direction that the gases can enter, to a distance from the explosion source that equals the distance from the source to the point of interest. For IBD, the point of interest is the tunnel opening.

**Loading docks**

Facilities, structures, or paved areas, designed and installed for transferring ammunition and explosives between any two modes of transportation.

**Lunchroom**

Facilities where food is prepared or brought for distribution by food service personnel. It may serve more than one PES. Personnel may use a breakroom in an operating building PES to eat meals. Lunchrooms generally require application of QD, breakrooms do not.

**Magazine**

Any building or structure, except an operating building, used for the storage of ammunition and explosives.

**Magazine distance**

The minimum distance permitted between any two magazines depending on the type of magazine and the class/division quantity of ammunition and explosives involved; the type and quantity of explosives requiring the greater distance will govern the magazine separation. Also called 'Intermagazine Separation'.

**Magazine, earth-covered, nonstandard**

All earth-covered magazines which are not constructed in accordance with DDESB approved drawings.

**Marshalling yard**

A port, point or location away from the congestion of a port facility where a unit or activity accounts for or assembles all their equipment and prepares for onward movement.

**Mass-detonating ammunition/explosives**

Ammunition or explosives, almost all of which can be expected to explode virtually instantaneously when a small portion is subjected to fire, to severe concussion or impact, to the impulse of an initiating agent, or to the effect of a considerable discharge of energy.

**Material potentially presenting an explosive hazard**

Material potentially containing explosives or munitions (such as, munitions containers and packaging material; munitions debris remaining after munitions use, demilitarization, or disposal; and range-related debris); or material potentially containing a high enough concentration of explosives such that the material presents an explosive hazard (for example, equipment, drainage systems, holding tanks, piping, or ventilation ducts that were associated with munitions production, demilitarization or disposal operations). Excluded from MPPEH are munitions within DOD's established munitions management system and other hazardous items that may present explosion hazards (such as, gasoline cans, compressed gas cylinders) that are not munitions and are not intended for use as munitions.

**Maximum credible event**

In hazards evaluation, the maximum credible event from a hypothesized accidental explosion, fire, or agent release is the worst single event that is likely to occur from a given quantity and disposition of ammunition and explosives. The event must be realistic, with a reasonable probability of occurrence considering the explosion propagation, burning rate characteristics, and physical protection given to the items involved.

**Munitions and explosives of concern scrap**

Non-explosive munitions-related material recovered during the course of an MEC removal. Examples are fragments, empty cartridge cases, expended pyrotechnics, and ammunition packing material.

**Munitions and explosives of concern safety specialist**

DOD personnel, classified as a GS-018 Safety Specialist, and who are UXO qualified. The MEC safety specialists perform safety, quality assurance and MEC subject matter expert functions for the Government.

**Military munitions**

All ammunition products and components produced or used by or for the DOD or the U.S. Armed Services for national defense and security, including ammunition products or components under the control of the DOD, the U.S. Coast Guard, the DOE, and National Guard personnel. The term military munitions includes: confined gaseous, liquid, and solid propellants, explosives, pyrotechnics, chemical and riot control agents, smokes, and incendiaries used by DOD components, including bulk explosives and chemical warfare agents, chemical munitions, rockets, guided and ballistic missiles, bombs, warheads, mortar rounds, artillery ammunition, small arms ammunition, grenades, mines, torpedoes, depth charges, cluster munitions and dispensers, demolition charges, and devices and components thereof. Military munitions do not include wholly inert items, improvised explosive devices, and nuclear weapons, nuclear devices and

nuclear components thereof. However, the term does include non-nuclear components of nuclear devices, managed under DOE's nuclear weapons program, after all required sanitizing operations under the Atomic Energy Act of 1954, as amended, have been completed.

**Military munitions burial site**

A site, regardless of location, where military munitions or CA, regardless of configuration, were intentionally buried, with the intent to abandon or discard. This term includes burial sites used to dispose of military munitions or CA, regardless of configuration, in a manner consistent with applicable environmental laws and regulations or the national practice at the time of burial. It does not include sites where munitions were intentionally covered with earth during authorized destruction by detonation, or where in-situ capping is implemented as an engineered remedy under an authorized response action.

**Military pyrotechnics**

Ammunition manufactured specifically for use as signals, illuminants, and like items.

**Minimum separation distance**

The distance at which personnel in the open must be from an intentional or unintentional detonation.

**Misfire**

Failure of a component to fire or explode following an intentional attempt to cause an item to do so. (See dud.)

**Module**

A barricaded area comprised of a series of connected cells with hard surface storage pads separated from each other by barricades.

**Munitions constituents**

Any materials originating from ordnance, unexploded ordnance, discarded military munitions, or other military munitions, including explosive and nonexplosive materials, and emission, degradation, or breakdown elements of such ordnance or munitions.

**Munitions and explosives of concern**

Synonymous with OE. The MEC consists of military munitions that are either UXO or are abandoned or discarded; soil with a high enough concentration of explosives to present an explosive hazard; facilities, equipment, or other materials contaminated with a high enough concentration of explosives such that it presents an explosion hazard.

**Munition with the greatest blast hazard**

As used in munitions response actions, refers to the munition at an MRS with the greatest NEWQD.

**Munitions with greatest fragment distance**

For MEC removal operations, the round with the greatest fragment range that can reasonably be expected to exist in any particular MEC area.

**Munition with the greatest fragment penetration capability**

As used in munitions response actions, refers to the munition at an MRS whose primary fragments have the greatest penetration capability per DDESB Tech Paper 16 as listed by DDESB on the Fragmentation Data page of their TP 16 web page.

**Munition with the greatest hazardous fragment distance**

As used in munitions response, refers to the munition at an MRS with the greatest hazardous fragment distance per DDESB Tech Paper 16 as listed by DDESB on the Fragmentation Data page of their TP 16 web page.

**Munition with the greatest maximum fragment distance**

As used in munitions response, refers to the munition at an MRS with the greatest horizontal primary fragment distance (for example, the greatest distance to which any single primary fragment will travel, at a 99 percent confidence level) per DDESB Tech Paper 16 as listed by DDESB on the Fragmentation Data page of their TP 16 Web page.

**Munitions response**

Response actions, including investigation, removal actions and remedial actions to address the explosives safety, human health, or environmental risks presented by UXO, DMM, or MC.

**Munitions response area**

Any area on a defense site that is known or suspected to contain UXO, DMM, or MC. Examples include former ranges and military munitions burial sites. A munitions response area is comprised of one or more munitions response sites.

**Munitions response site**

A discrete location within an MRA that is known to require a munitions response.

**Navigable streams**

Those parts of streams, channels, or canals capable of being used in their ordinary or maintained condition as highways of commerce over which trade and travel are or may be conducted in the customary modes, not including streams that are not capable of navigation by barges, tugboats, and other large vessels unless they are used extensively and regularly for the operation of pleasure boats.

**Net explosive quantity**

Net explosive quantity (expressed in kilograms).

**Net explosive weight**

Net explosive weight (expressed in pounds).

**Noncombustible**

Not burnable in the ordinary sense of the word.

**Nonarmored**

A vehicle or site that has no design protective features. For example an ISO container would be considered non-armored for QD purposes.

**Nonessential personnel**

Nonessential personnel are personnel that perform support functions, which can be executed without exposure to AE hazards and risks (such as, medical support personnel, administrative personnel, stock-records clerks, and so forth) See definition of essential personnel above.

**Non-DOD component**

Any entity (government, private, or corporate) that is not a part of the Department of Defense.

**Non-intrusive activity**

An activity that does not involve intentional physical contact with MEC or intentional penetration of the ground surface at an area known or suspected to contain MEC. Examples are site inspections, surveying, burning or cutting vegetation, grid and lane marking, geophysical mapping, and detecting and flagging anomalies.

**Norobust munitions**

Those items that do not meet the definition of Robust or Fragmenting munitions. Examples include torpedo warheads, underwater mines, most CBUs, and TOW and Hellfire missiles.

**Non-time-critical response action**

Actions initiated in response to a release or threat of a release that poses a risk to human health, its welfare, or the environment. Initiation of response cleanup actions may be delayed for six months or more.

**Normal maintenance**

Work performed on ammunition to prevent deterioration and to correct minor defects not requiring renovation or major modification operations.

**On-site**

As applied to munitions response actions, the MRS containing MEC and all areas in proximity to the MEC that are necessary to implement the response action.

**Operating building**

Any structure, except a magazine, in which operations pertaining to manufacturing, processing, handling, loading, or assembling of ammunition and explosives are performed.

**Operating line**

A group of buildings, facilities, or related work stations so arranged as to permit performance of the consecutive steps in the manufacture of an explosive or in the loading, assembly, modification, and maintenance of ammunition.

**Operational necessity**

A situation where the mission commander determines the amount of ammunition stored based upon careful evaluation of the mission requirements. The qualifier ‘operational necessity’ is intended to provide commanders the flexibility to ensure mission performance, to include training, without a waste of resources, however, it is not intended to allow such storage for just for convenience. In no situation can operational necessity dictate that safe storage practices or quantity and distance criteria be violated without executing a CORA or where grandfathered by a waiver or exemption.

**Operational range**

A range that is under the jurisdiction, custody, or control of the Secretary of Defense and that is used for range activities; or although not currently being used for range activities, that is still considered by the Secretary to be a range and has not been put to a new use that is incompatible with range activities (10 USC 101(e)(3)(a) and (b)). Also includes “military range,” “active range,” and “inactive range” as those terms are defined in 40 CFR 266.201.

**Operational shield**

A barrier constructed at a particular location or around a particular machine or operating station to protect personnel, material, or equipment from the effects of a possible localized fire or explosion.

**Operator**

A person assigned to perform a specific, generally continuing function on a production, maintenance, renovation, or disposal line or operation. Typically the functions are performed at workstations or areas defined in an SOP.

**Operator workstation**

A specific location within a line or production area where an operator is assigned on a continuing basis to perform operations described in the relevant SOP.

**Ordnance and explosives**

See MEC.

**Outdoor storage sites**

Locations selected within the magazine area for the storage of ammunition and, in exception cases, inert items.

**Personnel protection**

Elimination or positive control of ignition and initiation stimuli. Sufficient distance or barricades to protect from blast or fragments. In those areas of facilities where exposed thermally energetic materials are handled that have a high probability of ignition and a large thermal output as indicated by hazard assessments, fire detection, and extinguishing system that is sufficiently quick-acting and of adequate capacity to extinguish potential flash fires in their incipient state will protect both personnel and property. Design and installation of the system must maximize speed of detection and application of the extinguishing agent. In ammunition operational areas where it is essential for personnel to be present and the hazard assessment indicates that an in-process thermal hazard exists, use of thermal shielding between the thermal source and personnel is an acceptable means of protection. If shields are used, they shall comply with MIL-STD-398. If shielding is not possible, or if that provided is inadequate for protection of exposed personnel, including their respiratory and circulatory systems, augmentation with improved facility engineering design, personnel protective clothing and equipment may be necessary. Thermal protective clothing must be capable of limiting bodily injury to first degree burns (0.3 calories per square centimeter per second with personnel taking turning-evasive action) when the maximum quantity of combustible material used in the operation is ignited. Protective clothing selected must be capable of providing respiratory protection from the inhalation of hot vapors and toxicological effects when the hazard assessment indicates adverse effects would be encountered from the inhalation of combustion products. Personnel hazards from glass breakage can be minimized by means such as building orientation and/or keeping the number of exposed glass panels and panel size to a minimum. When window panels are necessary and risk assessment determines a glass hazard will be present, blast resistant windows must be used. The framing and/or sash of such panels must be of sufficient strength to retain the panel in the structure.

**Pier**

A landing place or platform built into the water, perpendicular or oblique to the shore, for the berthing of vessels.

**Positive control**

At a burning site, this is a means to prevent items, energetic material, or embers from being ejected to a place where they could cause injury or damage.

**Potential explosion site**

The location of a quantity of explosives that will create a blast, fragment, thermal, or debris hazard in the event of an accidental explosion of its contents.

**Practice ammunition**

Ammunition or ammunition components used for training. Practice ammunition simulates a service item in weight, design, and ballistic properties. A practice round may be inert or have a small quantity of explosive filler, such as black powder, used as a spotting charge.

**Primary explosives**

Primary explosives are highly sensitive compounds that are typically used in detonators and primers. A reaction is easily triggered by heat, spark, impact or friction. Examples of primary explosives are lead azide and mercury fulminate.

**Primary girdle**

A ground loop (counterpoise) earth electrode subsystem which is connected to the lightning protection subsystem at former U.S. Navy installations.

**Process steam**

Steam that is in direct contact with explosives or which, in case of equipment failure, would exhaust directly into contact with explosives or explosives vapors.

**Prohibited area**

A specifically designed area at airfields, seadromes, or heliports in which all ammunition and explosives facilities are prohibited.

**Propellant, solid**

Explosives compositions used for propelling projectiles and rockets and to generate gases for powering auxiliary devices.

**Public traffic route**

Any public street, road, highway, navigable stream, or passenger railroad (includes roads on a military reservation that are used routinely by the general public for through traffic). At this distance personnel may be injured due to fragments and debris. They may sustain temporary hearing loss. Vehicles and aircraft may receive fragment damage but with minor repair will be operational. Unstrengthened buildings are likely to receive moderate damage. Ammunition supplies should be useable following an explosives event.

**Pyrotechnic material**

The explosive or chemical ingredients, including powdered metals, used in the manufacture of military pyrotechnics.

**Quality assurance specialist (ammunition surveillance)**

Department of the Army civilians that function in the ammunition surveillance program at DOD installations, activities, and commands that receive, store, maintain, issue, use, and dispose of ammunition.

**Quantity-distance**

The quantity of explosives material and distance separation relationships that provide defined types of protection.

**Quay**

A marginal wharf or solid fill.

**Range**

A designated land or water area that is set aside, managed, and used for range activities of the Department of Defense. The term includes firing lines and positions, maneuver areas, firing lanes, test pads, detonation pads, impact areas, electronic scoring sites, buffer zones with restricted access, and exclusionary areas. The term also includes airspace areas designated for military use in accordance with regulations and procedures prescribed by the Administrator of the Federal Aviation Administration. (10 U.S.C. 101(e)(1)(A) and (B)).



**Ready ammunition storage**

A location where ammunition is stored for near term tactical or training use. Generally, ready ammunition storage locations will supply one or more armament pads.

**Real property**

Land and buildings, including buildings' installed equipment.

**Remote operation**

An operation sufficiently hazardous such that special protection to personnel is required. Protection is provided by distance, protective construction (shielding, barricades, and so forth) or both.

**Removal action**

For MEC projects, refers to the cleanup or removal of MEC from the environment to include the disposal of removed materiel. The term includes, in addition, without being limited to, security fencing or other measures to prevent, minimize, or mitigate damage to the public health or welfare or to the environment.

**Render safe procedures**

Military EOD procedures that physically or mechanically alter or disrupt UXO to reduce its sensitivity to accidental explosive functioning.

**Renovation**

That work performed on ammunition, missiles, or rockets to restore them to a completely serviceable condition; usually involves the replacement of unserviceable or outmoded parts.

**Response action**

For MEC projects, refers to the process of evaluating and, if appropriate, reducing the risk of exposure resulting from military MEC. An action that begins with a site characterization but ends with a NOFA or NDAI is a response. If further action is warranted, risk reduction actions are taken. Risk reduction actions may include removal of MEC and treatment on-site to eliminate its explosives properties; transportation off-site to a storage or treatment facility; land use controls; engineering controls; public education, or other action necessary to protect the public. Explosives or munitions emergency responses, time-critical responses, non time-critical responses, and remedial actions are all considered risk reduction measures.

**Restricted area**

Any area, usually fenced, at an establishment where the entrance and egress of personnel and vehicular traffic are controlled for reasons of safety.

**Risk**

The expected damage or consequences expressed as the product of the consequence's probability and severity.

**Risk acceptance**

The management process of having the proper authority to review and accept risks.

**Risk assessment**

The evaluation of the risk associated with an activity which may include one or more analysis methodologies.

**Risk assessment code**

An expression of the risk associated with a hazard. In accordance with AR 385-10 and DA Pam 385-10, the RAC combines the hazard severity and accident probability into a single term.

**Risk decision**

The decision to accept or not accept the risks associated with an action made by an individual responsible for performing that action.

**Risk management**

The practice of assessing risk and thereafter accepting the risk based on a consistent logic.

**Robust Munitions**

These are munitions that meet two of the following three criteria: have a ratio of the explosive weight to empty case weight less than 1.00; have a nominal wall thickness of at least 0.4 inches; have a case thickness/NEW<sup>1/3</sup> 0.05 in/lb<sup>1/3</sup>.

The following cartridges are, by definition, robust: 20 mm, 25 mm, and 30 mm. Other examples of robust ammunition include MK 80 series bombs, M107 projectiles, Tomahawk and Harpoon penetration warheads.

**Rock strength**

Strong, moderately strong, and weak rock are designators which provide a general classification of rock types for siting underground storage facilities. Classification of a rock body into one of these three rankings involves the rock's density, unconfined compressive strength and seismic velocity as specified in Corps of Engineers definitive design drawing number DEF 421-80-04.

**Rocket**

A motor which derives its thrust from ejection of hot gases generated from propellants carried within the motor casing.

**Rocket motor**

That portion of the complete rocket which is loaded with propellant.

**Runway**

Any surface on land designated for aircraft takeoff and landing operations, or a designated lane of water for takeoff and landing operations of seaplanes.

**Safety shoes**

Specifically designed footwear to protect the feet from various hazards. All shoes certified under Z41 must meet the impact and compression requirements. Shoes may be designed to also meet requirements for metatarsal protection, protection from electrical hazards, puncture resistance, conductivity, and static dissipative. Conductive footwear is designed to dissipate static electricity from the body to the ground to reduce the possibility of ignition of explosive mixtures or volatile chemicals

**Scuttling site**

An area of water specifically designated for positioning a ship for its flooding or sinking under emergency conditions.

**Secondary explosives**

Secondary explosives are generally less sensitive to initiation than primary explosives and are typically used in booster and main charge applications. A severe shock is usually required to trigger a reaction. Examples are TNT, cyclo-1,3,5-trimethylene-2,4,6-trinitramine (RDX or cyclonite), HMX, and tetryl.

**Secondary girdle**

A ground loop (counterpoise) earth electrode subsystem which is connected to all grounding subsystems except the lightning protection subsystem at former U.S. Navy installations.

**Secure explosives holding area**

An area designated for the temporary parking of commercial carriers' motor vehicles transporting DOD AAE. (See DTR 4500.9-R, part 205 and part II, Cargo)

**Secure Non-explosives Holding Area**

An area designated for the temporary parking of commercial carriers' motor vehicles transporting categorized DOD arms, classified (SECRET or CONFIDENTIAL) materials, and CCI. (See DTR 4500.9-R, part 205 and part II, Cargo)

**Semi-fixed ammunition**

Ammunition loaded into a weapon in one operation and whose cartridge case is not firmly attached to the projectile so that the propelling charge may be adjusted for zone firing.

**Senior unexploded ordnance supervisor**

Supervises all contractor on-site MEC activities. This individual will be a graduate of the U.S. Army Bomb Disposal School, Aberdeen Proving Ground, MD or the U.S. Naval Explosive Ordnance Disposal School, Indian Head, MD. This individual will have combined active duty military EOD and contractor MEC experience, including experience in supervisory positions. Experience in active duty in military EOD units is required. This individual will have documented experience with or specialized training in the type of MEC expected to be encountered on the site.

**Service line**

Electrical lines supplying individual or unique installation locations.

**Service magazine**

A building of an operating line used for the intermediate storage of explosives materials.

**Ship or barge units**

All explosives within a line encompassing the ship or barge being loaded, the space on the pier for spotting of freight cars and trucks, and the space in the water for barges which may be working the ship or barge.

**Simultaneous detonation**

Detonation of separated quantities of explosives of ammunition occurring so nearly at the same time that the effect on the surroundings is the same as if the several quantities were not separated and were detonated en masse.

**Similar risk**

Similar risk when applied to ammunition and explosives represents a condition where the risk between AE operations is of the same magnitude. In order for the risk of AE operations to be considered of the same magnitude, the severities and probabilities of the operations being compared must produce the identical level of risk (such as, risk assessment code) in accordance with DA Pam 385–30. The risk for each operation must be independently evaluated and then compared. During the determination of risks when developing the probability, the analysis will consider the reactivity, sensitivity, ignition stimuli, and likelihood of ignition. When determining the severity, the analysis will consider fragmentation distances, overpressures, thermal flux, effects of fire, survivability of the structure, and criticality of the structures to the mission as well as political ramifications.

**Single-chamber storage site**

An excavated chamber with its own access to the natural ground surface not connected to any other storage chamber.

**Site inspection for munitions and explosives of concern**

Activities undertaken to determine whether there is known or potential presence of MEC and the nature associated threats. The purpose is to augment the data collected in prior site data gathering efforts to generate field data to determine the presence, type, distribution, density and location of MEC. The results of the SI are reported in an Archives Search Report. Intrusive investigation is not normally conducted during a site inspection for MEC.

**Site-specific safety and health plan**

For MEC projects, refers to a plan that defines work activities specific to the project site, the hazards associated with those activities, and the means for controlling those hazards. The elements of a site-specific safety and health plan include:

- a. a background statement, describing the uses of the site that lead to the presence of MEC.
- b. a map delineating site boundaries, details of structures, transportation routes, utilities, pertinent topographic features, and locations of MEC sampling, recovery, storage and treatment.
- c. a listing of types and quantities of MEC anticipated on site.
- d. a description of site activities, hazards, and the means of hazard control.
- e. a description of site security.

**Site-specific work plan**

A plan that defines work activities specific to the project site and prescribes procedures to be employed in executing work activities.

**Sling out area**

The loading of AE into cargo nets for transportation beneath a helicopter for supply of units not accessible by ground transportation or when time or security is a critical factor.

**Small arms ammunition**

Ammunition, without projectiles that contain explosives (other than tracers), that is .50 caliber or smaller, or for shotguns.

**Spall**

Spall refers to pieces of a material (and the process by which they are formed) that are broken loose from the surface of a parent body by tensile forces that are created when a compression shock wave travels through the body and reflects from the surface. For underground storage, spall normally refers to the rock broken loose from the wall of an acceptor chamber by the shock wave transmitted through the rock from an explosion in a nearby donor chamber.

**Stakeholders**

In MEC response planning, refers to Federal, state and local officials, Federally recognized tribes, community

organizations, property owners, and others having an interest or involvement, or having a monetary or commercial involvement in the real property that is to undergo an MEC response action.

**Standard igloo magazine**

An earth-covered, arch-type magazine with or without a separate door barricade, constructed according to an approved standard drawing identified in chapter 8.

**Static missile battery**

Deployed ground-based missiles meant to be employed in a non-mobile mission for offensive or defensive purposes.

**Static test stand**

Locations on which liquid propellant engines or solid propellant motors are tested in place.

**Storage compatibility**

A relationship between different items of ammunition, explosives, and other dangerous materials whose characteristics are such that a quantity of two or more of the items stored or transported together is no more hazardous than a comparable quantity of any one of the items stored alone.

**Substantial dividing wall**

An interior wall designed to prevent simultaneous detonation of quantities of explosives on opposite sides of the wall.

**Support facilities**

Ammunition and explosives storage or operations that support solely the functions of tactical or using units as distinguished from storage depots or manufacturing facilities.

**Surface**

As applies to munitions response, refers to MEC which is: (A) entirely or partially exposed above the ground surface (for example, the top of the soil layer); or (B) entirely or partially exposed above the surface of a water body (for example, because of tidal activity).

**Surveillance**

The observation, inspection, investigation, test, study, and classification of ammunition, ammunition components, and explosives in movement, storage, and use with respect to degree of serviceability and rate of deterioration.

**Surveillance workshop**

A special building equipped to permit all normal ammunition surveillance inspections.

**Suspect truck and car site**

A designated location for placing trucks and railcars containing ammunition or explosives that are suspected of being in hazardous conditions. These sites are also used for trucks and railcars that may be in a condition that is hazardous to their contents.

**Tactical facilities**

Prepared locations with an assigned combat mission, such as missile launch facilities, alert aircraft parking areas, or fixed gun positions.

**Taxiway or taxilane**

Any surface designated as such in the basic airfield clearance criteria specified by a DOD component publication or Federal Aviation Regulation.

**Technology-aided surface removal**

A removal of UXO, DMM, or CWM on the surface (such as, the top of the soil layer) only, in which the detection process is primarily performed visually, but is augmented by technology aids (such as, handheld magnetometers or metal detectors) because vegetation, the weathering of UXO, DMM, or CWM, or other factors make visual detection difficult.

**Time-critical response action**

A response to a release or threat of release that poses such a risk to public health (serious injury or death), or the environment, that clean up or stabilization actions must be initiated within six months. In terms of urgency, these actions lie between munitions emergency responses and non time-critical responses. In many cases, a time critical

response is done to abate the worst hazards at a site, and a non-time critical response or remedial action is done later to further abate hazards.

### **Transient**

A person with official business on a production line or operation but who is not routinely assigned to a specific limited location.

### **Transmission lines**

Electrical lines supplying locations outside the garrison or installation uniquely, or in common with garrison or installation locations.

### **Unconfined burning**

The burning of energetic material which have a means of venting without appreciable movement.

### **Unexploded ordnance**

Military munitions that have been primed, fused, armed, or otherwise prepared for action, and have been fired, dropped, launched, projected, or placed in such a manner as to constitute a hazard to operations, personnel, or material and remains unexploded either by malfunction, design, or any other cause.

### **Utilities**

Those services required for the operation of an establishment such as water, air, steam, sewage, telephone, and electricity.

### **Unexploded ordnance personnel**

Contractor personnel who have completed specialized military training in EOD methods and have satisfactorily performed the EOD function while serving in the military or who have completed a DOD certified UXO Technician Level 1 course. Various grades and contract positions are established based on skills and experience.

### **Unexploded ordnance specialist**

A UXO technician I, II, or III

### **Unexploded ordnance technician I**

This individual will be a graduate of the EOD Assistant's Course at Redstone Arsenal, AL; Eglin AFB, FL or a DOD certified equivalent course. A UXO Assistant may advance to a UXO Specialist category after obtaining active duty military EOD and contractor MEC experience. A UXO Assistant will not perform UXO procedures without the direct supervision of a UXO Specialist, UXO Supervisor, or Senior UXO Supervisor.

### **Unexploded ordnance technician II**

This individual shall be a graduate of the U.S. Army Bomb Disposal School, Aberdeen Proving Ground, MD or U.S. Naval EOD School, Indian Head, MD. The UXO Specialist may be a UXO Assistant with combined military EOD and contractor MEC experience.

### **Unexploded ordnance technician III**

Supervises a UXO team. This individual will be a graduate of the U.S. Army Bomb Disposal School, Aberdeen Proving Ground, MD or the U.S. Naval Explosive Ordnance Disposal School, Indian Head, MD. This individual will have combined active duty military EOD and contractor MEC experience. This individual will have experience in MEC clearance operations and supervising personnel.

### **Waiver**

A written authority that permits a temporary deviation from a short term (5 years or less) mandatory requirement of U.S. Army Ammunition and Explosives Safety Standards. Existing waivers will not be renewed and will be replaced with a CORA if the hazard has not been rectified. All existing waivers will be replaced by 1 October 2011.

### **Warhead**

That portion of a rocket or guided missile containing the high explosives charge or other destructive agent.

### **Waste military munitions**

A military munitions is a 'waste' if it is either a solid or hazardous waste under regulations implementing RCRA, (42 U.S.C. Section 9601 et seq.) or defined as a waste under a DOD Component's formal written policies and procedures. In general:

- a. a. An unused military munitions is a solid waste when any of the following occurs.

(1) The munitions is abandoned by being disposed of, burned, detonated (except during intended use), incinerated, or treated prior to disposal; or

(2) The munitions is removed from storage in a military magazine or other storage area for the purpose of being disposed of, burned, or incinerated, or treated prior to disposal, or

(3) The munitions is deteriorated or damaged (for example, the integrity of the munitions is compromised by cracks, leaks, or other damage) to the point that it cannot be put into serviceable condition, and cannot reasonably be recycled or used for other purposes; or

(4) An authorized military official has declared the munitions a solid waste.

*b. b.* A used or fired military munitions are a solid waste:

(1) When transported off range or from the site of use, where the site of use is not a range, for the purposes of storage, reclamation, treatment, disposal, or treatment prior to disposal; or

(2) If recovered, collected, and then disposed of by burial or landfilling either on or off a range.

(3) For purposes of RCRA section 1004(27), a used or fired military munitions is a solid waste, and, therefore, is potentially subject to RCRA corrective action authorities under Section 3004(u) and (v), and Section 3008(h), or imminent and substantial endangerment authorities under Section 7003, if the munitions lands off-range and is not promptly rendered safe and/or retrieved. Any imminent and substantial threats associated with any remaining material must be addressed. If remedial action is not feasible, the operator of the range must maintain a record of the event for as long as any threat remains. The record must include the type of munitions and its location (to the extent the location is known). For further clarification see 40 CFR 266.202 under Definition of Solid Waste.

#### **Weapons assembly area**

An area established at an airfield ASP to facilitate assembly/disassembly of ammunition required supporting the aviation mission.

#### **Wharf**

A landing place or platform built into the water or along the shore for the berthing of vessels.

#### **Wharf yard**

A yard that is close to piers or wharves in which railcars or trucks are held for short periods of time before delivery to the piers or wharves.

### **Section III**

#### **Special Abbreviations and Terms**

**UNCLASSIFIED**

**PIN 074126-000**

# USAPD

ELECTRONIC PUBLISHING SYSTEM  
OneCol FORMATTER WIN32 Version 271

PIN: 074126-000

DATE: 05-24-11

TIME: 13:01:03

PAGES SET: 332

---

DATA FILE: C:\Wincomp\p385-64.fil

DOCUMENT: DA PAM 385-64

SECURITY: UNCLASSIFIED

DOC STATUS: REVISION