

DEPARTMENT OF ENVIRONMENTAL PROTECTION
Bureau of Environmental Cleanup and Brownfields

DOCUMENT NUMBER: 263-0900-011

TITLE: Storage Tank Modification and Maintenance Issues

EFFECTIVE DATE: Upon Publication in PA Bulletin

AUTHORITY: The Storage Tank and Spill Prevention Act, P.L. 169, No. 32 of 1989 as amended (Tank Act), and 25 Pa. Code, Chapter 245 (Storage Tank Regulations).

POLICY: It is the policy of the Department of Environmental Protection (DEP) to carry out the provisions of the Storage Tank and Spill Prevention Act of 1989 as amended and related regulations.

PURPOSE: This guidance specifies the classification of various storage tank system modification and maintenance activities and when certified installers/inspectors are required.

APPLICABILITY: This guidance is primarily applicable to certified companies, inspectors and installers, and may be helpful to owners and operators of aboveground and underground storage tank systems or storage tank facilities.

DISCLAIMER: The policies and procedures outlined in this guidance are intended to supplement existing requirements. Nothing in the policies or procedures shall affect regulatory requirements.

The policies and procedures herein are not an adjudication or a regulation. There is no intent on the part of DEP to give the rules in these policies that weight or deference. This document establishes the framework within which DEP will exercise its administrative discretion in the future. DEP reserves the discretion to deviate from this policy statement if circumstances warrant.

PAGE LENGTH: 10 pages

MODIFICATION AND MAINTENANCE ISSUES

DEFINITIONS: The following definitions are found in 25 Pa. Code, §245.1 and are provided here with added guidance for clarification where noted.

Ancillary Equipment – Electrical, vapor recovery, access or other systems and devices, including, but not limited to, devices, such as piping, fittings, flanges, valves and pumps used to distribute, meter, monitor or control the flow of regulated substances to or from a storage tank system.

Containment Structure or Facility – Anything built, installed or established which comes in contact with regulated substances that are spilled, leaked, emitted, discharged, escaped, leached or disposed from a storage tank or storage tank system. The term includes, but is not limited to, a vault, dike, wall, building or secondary containment structure around an underground or aboveground storage tank, or any rock or other fill material placed around an underground storage tank.

Emergency Containment – A containment structure which serves to convey, capture and contain the total volume of an anticipated release of regulated substance from an aboveground or underground storage tank system and which is expeditiously emptied.

Excavation Zone – The volume containing the tank system and backfill material bounded by the ground surface, walls and floor of the pit and trenches into which the underground storage tank system is placed at the time of installation.

Maintenance – The normal operational upkeep to prevent a storage tank system or storage tank facility from releasing regulated substances if the activity involved is not a major modification or minor modification.

Major Modification –

- (i) An activity to upgrade, repair, refurbish or restore all or any part of an existing storage tank system or storage tank facility which:
 - (A) Alters the design of that storage tank system or storage tank facility.
 - (B) May affect the integrity of that storage tank system or storage tank facility.
- (ii) The term includes an activity directly affecting the tank portion of the storage tank system or an activity directly affecting an underground component of the storage tank system *“that is accessible only by breaking ground – which may include breaking and/or removal of concrete or backfill material, but does not include the displacement or removal of backfill material by hand – within the extent of the tank and piping installation excavation” (added guidance for clarification).*

Minor Modification –

- (i) An activity to upgrade, repair, refurbish or restore all or part of an existing storage tank system or storage tank facility which does not alter the design of that storage tank system or storage tank facility, but which may affect the integrity of that storage tank system or storage tank facility.
- (ii) The term does not include an activity directly affecting the tank portion of the storage tank system or an activity directly affecting an underground component of the storage tank system. *“However, the term may include an activity only affecting ancillary equipment, which is below grade (ground surface), but is readily accessible from aboveground through a manhole or containment sump opening and no excavation is involved in the activity – excepting the displacement or removal of backfill material by hand – when the activity does not involve the tank or alter the tank system design, as indicated in this guidance” (added guidance for clarification).*

Storage Tank Facility – One or more stationary tanks, including associated intrafacility pipelines, fixtures, monitoring devices and other equipment. A facility may include aboveground tanks, underground tanks or a combination of both. For the purposes of the act and this guidance, the associated intrafacility pipelines, fixtures, monitoring devices and other equipment for an aboveground storage tank shall be that which lies within the emergency containment area. The term storage tank facility does not encompass portions of a facility that do not contain storage tank systems.

Storage Tank System – An underground or aboveground storage tank, associated underground or aboveground piping directly serving that storage tank, and one or more of the following which are directly associated with that storage tank:

- (i) Ancillary equipment.
- (ii) Foundation.
- (iii) Containment structure or facility.
- (iv) Corrosion protection system.
- (v) Release detection system.
- (vi) Spill and overfill protection system.

Tank Handling Activity – Activities to install, modify or remove all or part of a storage tank system or storage tank facility. The term does not include maintenance activities. *“The term includes major modification and minor modification activities” (added guidance for clarification).*

TECHNICAL GUIDANCE:

The terms “Major Modification,” “Minor Modification” and “Maintenance” are defined in 25 Pa. Code, Chapter 245. Activities performed to upgrade, repair, refurbish or restore an existing storage tank system or storage tank facility can be categorized under one or more of these definitions. Moreover, modification activities are categorized as tank handling activities, while maintenance activities are not.

Tank handling activities must be performed by or under the direct, onsite supervision and control of a DEP certified installer – meaning the certified installer must be present throughout the duration of any tank handling activity – except that the modification of an aboveground nonmetallic storage tank may be performed by the tank manufacturer (See §245.21(a)). Tank handling activities conducted on any field constructed storage tank or on a large aboveground storage tank (tank having a capacity greater than 21,000 gallons) must also be inspected by a DEP certified inspector, except in the case of minor modification or tank removal activities (See §245.21(b)). For information on which certification categories are required for specific tank handling or related inspection activities, refer to Storage Tank Program Fact Sheet 2630-FS-DEP1647 “Understanding the Certification Categories” and see §245.110 or §245.112, respectively. Additionally, see §245.106 for conflict of interest provisions that are applicable to certified inspectors for tank handling activities.

Figure 1 depicts a decision chart to assist one with determining whether an activity is a major or minor modification, or maintenance activity.

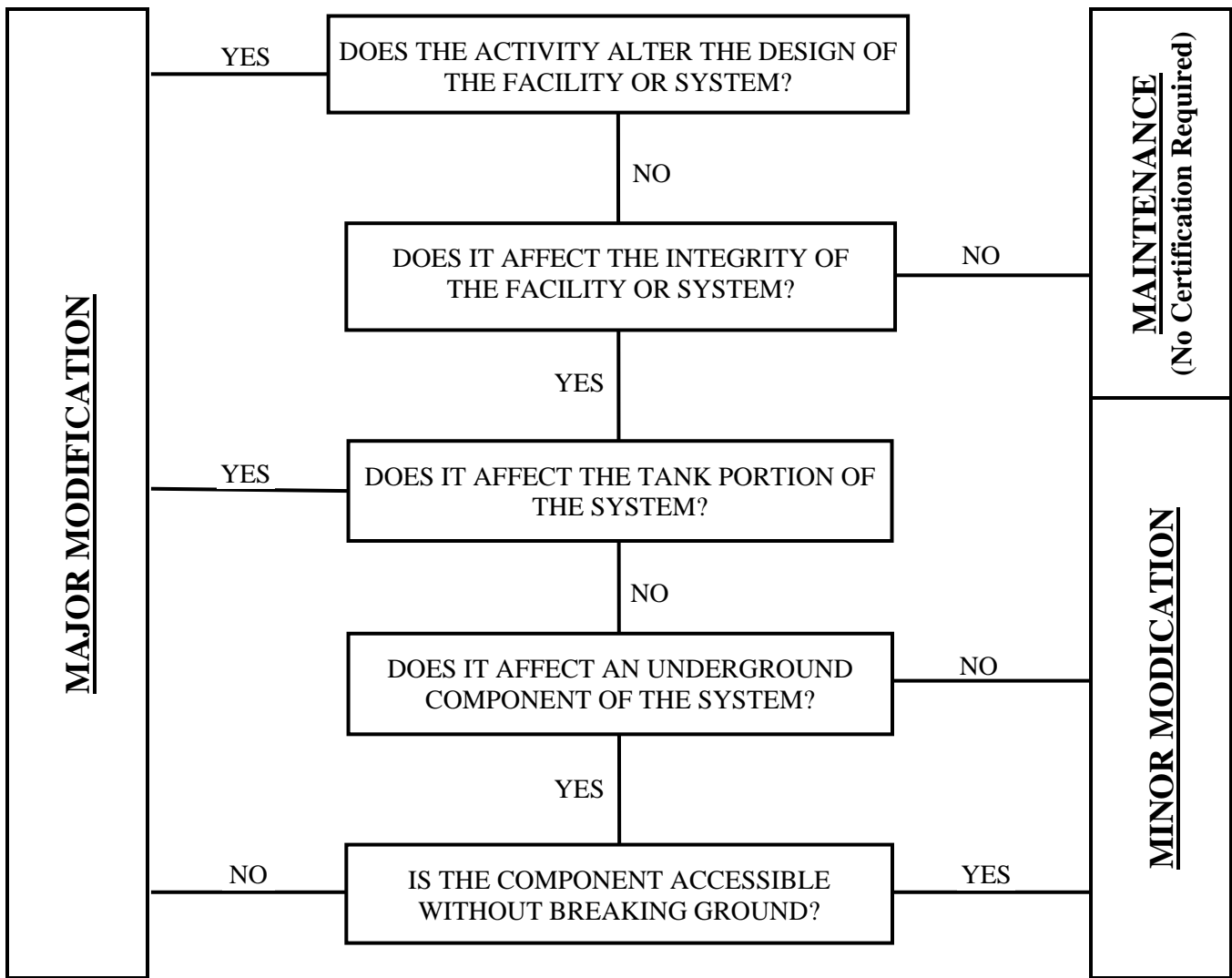

Figure 1 – Storage Tank System Modification/Maintenance Activity Decision Chart

An activity that directly affects the tank portion of an existing storage tank system is, generally, a major modification. If an activity affects the associated piping or other components of an existing storage tank system or storage tank facility, factors that may contribute toward the determination of its effect on the design and/or integrity of the storage tank system or storage tank facility, and thus its classification as a modification or maintenance activity, may include the accessibility of the component and its position, age and function relative to the storage tank system or storage tank facility; as well as the nature of the activity, and method(s) by which it is conducted.

For aboveground storage tank (AST) systems see the depictions in **Figure 2** (below), and **Figure 3** and **Figure 4** on page 5.

Major modifications to aboveground storage tank systems include:

- Replacement or repair of welded lines or fittings, manways, hot taps, welds on the tank or tank shell penetrations, or other tank shell openings up to the first control valve.
- Installation of new or additional piping runs within the emergency containment.

Minor modifications include:

- Initial installation of all piping, valves, pumps, gauges and vents for which the tank was designed, and fittings exist on the tank.
- Replacement or repair of piping or fittings, or cutting, torching, or welding of piping or fittings downstream from and including the first control valve, and within the emergency containment.

And maintenance activities include, when no cutting or welding is involved:

- Direct replacement (with like kind and function) or repair of threaded lines and fittings, flanged lines and fittings, pumps, valves or other tank appurtenances downstream of the first tank control valve.
- Direct replacement of gauges and vents for which the tank was designed and fittings exist on the tank.

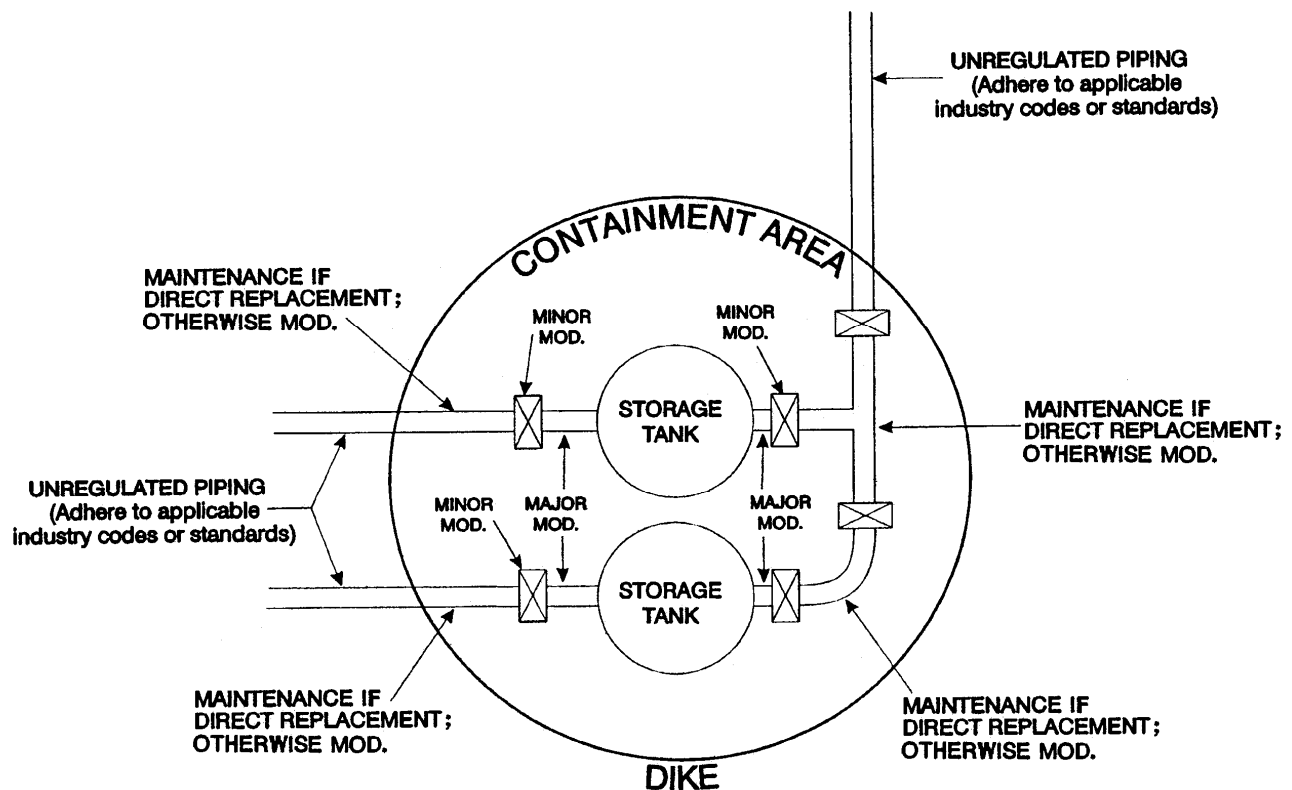

Figure 2 – Aerial view of example AST Systems within emergency containment.

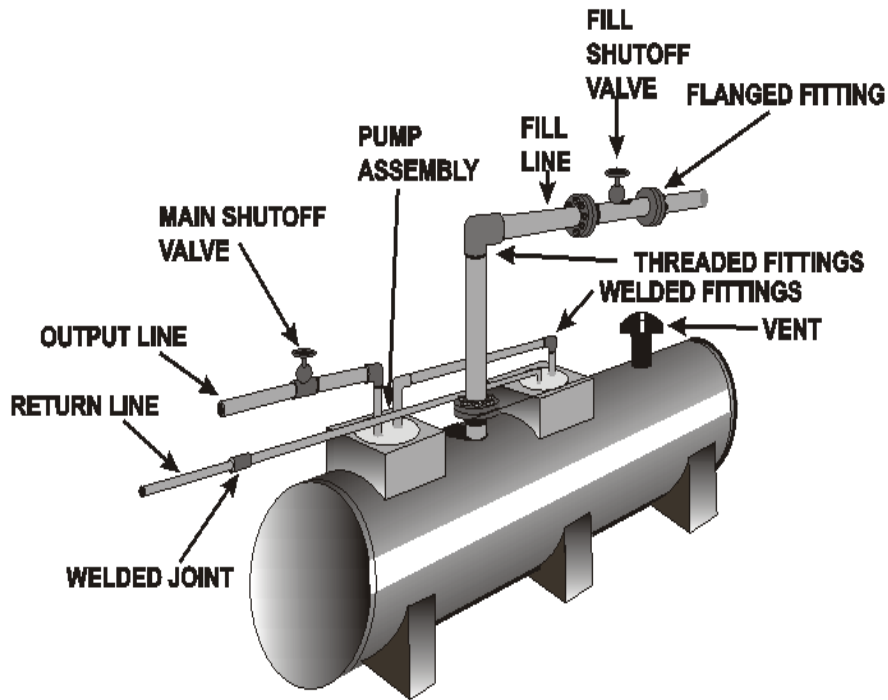

Figure 3 – Small Manufactured AST System (example area shown is within emergency containment)

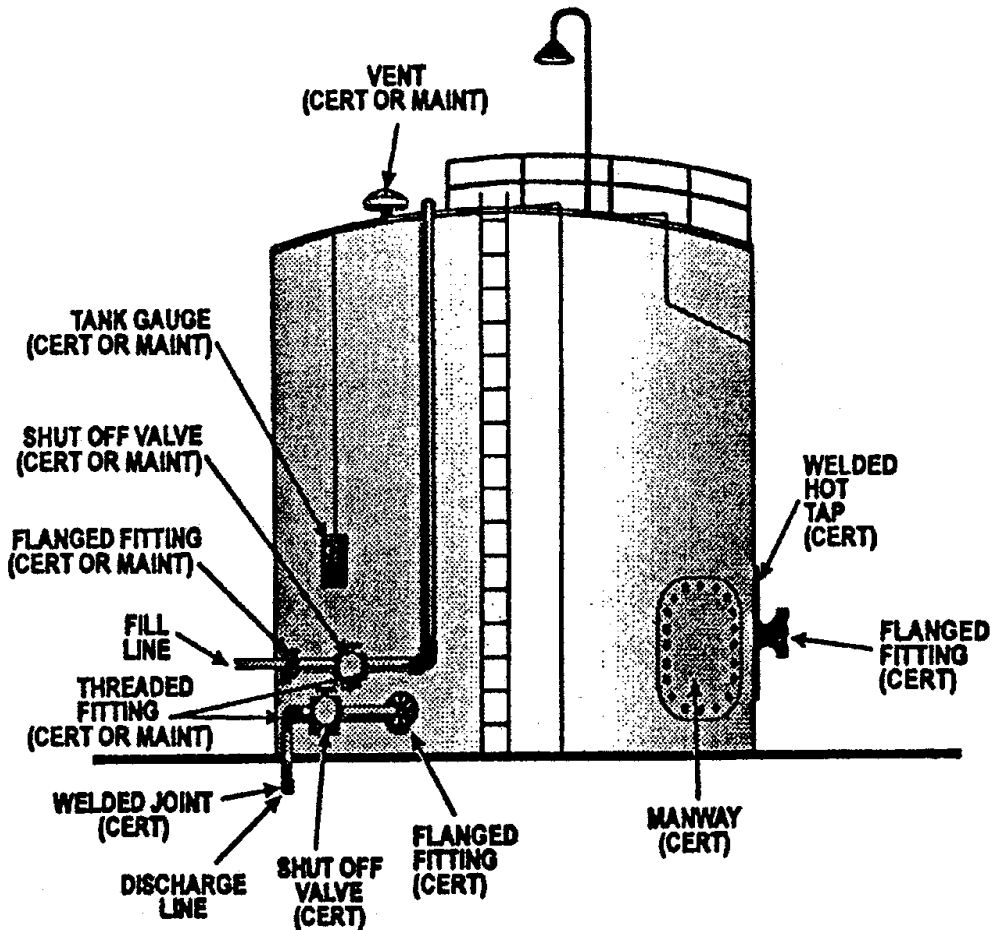

Figure 4 – Field Constructed AST System (example area shown is within emergency containment)

For underground storage tank systems, modification activities involving the removal and replacement of an existing dispenser may require the installation of under dispenser containment. When such activity involves construction at the dispenser island that disturbs the steel mounting frame of the existing dispenser, it is considered a major modification. For additional information, see §245.422(e) and Storage Tank Program Fact Sheets 2630-FS-DEP4175 “Underground Storage Tank Dispenser Containment” and 2630-FS-DEP4176 “Containment Testing for Underground Storage Tanks.”

Whether for aboveground or underground storage tank systems, modification activities and inspections must be properly documented on the appropriate form(s); which must be submitted to DEP. See the following Storage Tank Program forms and accompanying instructions for their completion and submittal requirements:

- 2630-FM-BECB0575 “Underground Storage Tank Modification Report”
- 2630-FM-BECB0151 “Aboveground Storage Tank Modification Report”
- 2630-FM-BECB0575 “Aboveground Storage Tank Modification Inspection Summary”

Modification activities may involve or be performed in conjunction with storage tank cleaning activities and/or a partial storage tank system closure. For storage tank cleaning activities, see Storage Tank Program guidance number 263-0900-012 “Storage Tank Cleaning Activities.” For removal or partial closure of a storage tank system, see guidance number 263-4200-001 “Closure Requirements for Aboveground Storage Tank Systems” and guidance number 263-4500-601 “Closure Requirements for Underground Storage Tank Systems.”

Equipment manufacturers may require trained or manufacturer licensed technicians to perform certain types of testing, modification or maintenance activities on specific equipment or system components. Always check the equipment manufacturer warranties, and maintenance manuals or equipment performance publications to prevent voiding warranties or performing improper maintenance. All maintenance activities should be performed by someone with appropriate knowledge of the storage tank system and experience in performing required maintenance, and in adherence to occupational safety practices.

These definitions, technical guidance, figures and examples are used to determine under which term an activity is placed. This will assist one in determining when a certified installer is required to perform the activity and when a certified inspector is required for field constructed tanks or large aboveground storage tank major modification activities. For additional information on underground storage tank (UST) maintenance and UST system depictions, see U.S. Environmental Protection Agency (EPA) publications 510-R-05-001 “UST Systems: Inspecting And Maintaining Sumps And Spill Buckets – Practical Help And Checklist” and 510-B-05-002 “Operating And Maintaining Underground Storage Tank Systems: Practical Help And Checklists” at EPA’s website (<http://www.epa.gov/oust/pubs>). And also the Petroleum Equipment Institute’s (PEI) recommended practices (RP) PEI/RP900 “Recommended Practices for the Inspection and Maintenance of UST Systems” and PEI/RP1200 “Recommended Practices for the Testing and Verification of Spill, Overfill, Leak Detection and Secondary Containment Equipment at UST Facilities.”

EXAMPLES: These examples of major modification, minor modification, and maintenance activities on aboveground and underground storage tank systems and storage tank facilities may not be all-inclusive, but rather reflect most frequently asked questions.

Major Modification Activities:

These activities may alter the design of the storage tank system or storage tank facility, and/or may affect the integrity of the storage tank system or storage tank facility; and may involve excavation during their performance.

Aboveground Storage Tank Systems

These activities performed on field constructed or large aboveground storage tanks require modification inspections by third-party inspectors appropriately certified by DEP.

- Replacement or addition of a tank shell plate or plates.
- Repair or replacement of the tank bottom or any partial repair or replacement of the tank bottom.
- Installation, repair or replacement of interior (internal) tank lining or coating.
- Installation, replacement or structural repair of the tank integral roof or of an internal floating roof.
- Initial penetrations of the tank shell, roof or bottom.
- Addition, repair or replacement of pipes directly between the tank shell, bottom or tank roof, and the first control valve outside the tank.
- Repair or replacement of welds on the tank.
- Installation or addition of equipment or appurtenances such as spill or overfill protection, tank gauging, stairways, platforms, walkways, or other similar additions that may put additional loads or stress on the tank shell, and were not part of the overall design considerations.
- Installation of new or additional piping runs within the emergency containment.
- Installation of corrosion protection systems or anodes on cathodic galvanic (sacrificial) and impressed current systems.
- Installation of new emergency or secondary containment structures.

Underground Storage Tank Systems

These activities performed on field constructed underground storage tanks require modification inspections by third-party inspectors appropriately certified by DEP.

- Repairing, removing or replacing any part of the tank.
- Replacing or repairing tank system components (including ancillary equipment and primary or secondary containment structures) when excavation is required.
- Replacement of a complete dispensing unit when excavation is required (requires liquid tight under dispenser containment, and includes partial system closure activity that must be performed or overseen by a UMR).
- Adding ancillary equipment.
- Installation, repair or replacement of internal tank lining or coating for product compatibility.
- Installation or replacement of corrosion protection systems – including the addition or replacement of anodes on cathodic galvanic (sacrificial) and impressed current systems – except when installing anode bags or spike anodes to only piping connectors, and excavation is only performed by hand (considered a minor modification).

Minor Modification Activities:

These activities DO NOT alter the design of the storage tank system or storage tank facility, but may affect the integrity of the storage tank system or storage tank facility. These activities MAY NOT (except as noted below) involve excavations during their performance.

Aboveground Storage Tank Systems

- Excavations within the emergency containment, but not under the tank or piping supports.
- Modifying or repairing emergency or secondary containment structures.
- Installation of equipment or appurtenances such as, spill containment, tank gauging, and vents for which the tank was designed and fittings exist on the tank shell or roof.
- Repairs involving cutting or welding on aboveground piping runs downstream from and including the first control valve, and within the emergency containment.

Underground Storage Tank Systems

- Staking and placing of concrete forms over the tank field and piping runs.
- Replacement, repair or removal of aboveground piping associated with the system (excluding dispenser components).
- Replacement of a complete dispensing unit, without excavation.
- Replacement, repair or removal of the check valve in a suction system.
- Replacement or removal of leak detector/pump-manifold (packer) assembly.
- Replacement, removal or disconnection of piping connectors.
- Replacement, removal or disconnection of break-away (shear) valves.
- Replacement or removal of primary piping through extraction from the secondary piping or double walled piping systems or double wall piping from a tertiary conduit when accessible from aboveground or through manholes (not involving an excavation).
- Repairs to cathodic protection systems that only involve replacement of a rectifier unit and/or the reconnecting of wires; so long as the only excavation involved is performed by hand.
- Installation or replacement of anode bags or spike anodes to piping connectors; so long as the only excavation involved is performed by hand.
- Installation or replacement of piping isolation boots; so long as the only excavation involved is performed by hand.
- Initial installation of a line leak detector.
- Changing the type of line leak detector, such as, mechanical to electronic.
- Installation, repair or replacement of overfill prevention devices.
- Installation, repair or replacement of spill containment devices; including the installation or replacement of drain valves or plugs.
- Initial installation or complete replacement of an automatic tank gauging system; or the replacement of an automatic tank gauge console.
- Repairs to primary or secondary containment structures – including the installation or repair of containment sump entry fittings – without excavation.

Maintenance Activities:

The normal operational upkeep to prevent a storage tank system or storage tank facility from releasing regulated substances if the activity involved is not a major modification or minor modification. These activities DO NOT involve excavations during their performance.

Aboveground and Underground Storage Tank Systems

- Painting the tank system exterior (except where excavation is required).
- Painting, caulking or minor surface repair to an emergency containment structure.
- Aboveground storage tank cleaning not performed as part of a tank closure activity; and, which does not involve the removal of any lining.
- Replacing the tank gauge on an aboveground tank when the gauge brackets already exist on the tank.
- Replacement of flame arrestors, pressure relief valves and conservation vents on aboveground tanks.
- Replacing product high-level sensors on an aboveground tank.
- Repair or direct replacement of threaded or flanged ancillary equipment located downstream of first control valve of an aboveground storage tank system.
- Replacement or repair of the tank pump or submersible turbine (with extractable column) if accessible through the manhole or tank riser sump (not involving removal or disconnect of packer manifold assembly or piping below the ground or grade surface).
- Repair of line leak detectors and repair or replacement of metering devices (with like kind devices) when accessible from aboveground or through manholes.
- Changing or replacing product dispenser components above the break-away (shear) valve (not involving piping disconnect at the valve).
- The decommissioning of a Stage II vapor-recovery system not involving excavation or tank handling activity; such as the replacement or removal of product dispensers, or the replacement, removal or disconnection of product piping, piping connectors and/or break-away (shear) valves.
- Emptying spill containment buckets and sumps.
- Repairing or replacing small copper lines or tubing accessible from aboveground or sump.
- Repair and recalibrating of the metering controls or automated console.
- Testing of the cathodic protection system (requires a qualified cathodic protection tester).
- Adjustments to rectifier settings (requires evaluation and adjustment determination by a corrosion expert or corrosion engineer).
- Installing temporary leak clamps.
- Repairing electrical connections.
- Changing electronic circuit boards.
- Changing filters.
- Gauging tanks.
- Checking the monitoring or observation wells.